

GADGETS**A Pulmonary Ventilator for Infants**

ROBERT N. REYNOLDS, M.D.*

An electronic ventilator was designed to meet the specific characteristics of respiration in premature and full-term neonates and infants up to one year of age. This provides physiologic controlled respiration during surgical anesthesia, the postoperative period and in all pediatric patients requiring artificial respiration. The characteristics of the ventilator are:

(1) Adjustable instantaneous gas flow (range 1–12 liter/minute); low flow consistent with the physiologic range in infants to avoid high flow resistance in small airways.

(2) Time-cycled tidal volume—adjustable control of frequency and tidal volume to meet physiologic range in any infant—range of frequency: 14–85 cycles/minute—(range of tidal volume: 15–100 ml./breath).

(3) Low internal compression volume—this characteristic permits avoidance of significant compression of the gas within the ventilator when the patient has a high resistance to inflation.

The ventilator weighs 6 pounds. It is transistorized and energized by a 7½ volt battery and can be used in the presence of explosive or flammable agents (fig. 1). If desired, a transformer connected to a regular 120 volt a.c. line can be utilized to power the ventilator. The power supply and control unit may be remotely located so that only the low voltage relay unit will be in proximity to high oxygen or anesthetic gas concentrations.

The line drawing in figure 2 shows the relation between the patient, the ventilator and the anesthesia machine or oxygen supply. A Y tube is an integral part of the system and is in line between the ventilator and the patient. The desired flow of gases enters the system from the anesthetic machine flow meters. The gas flow is set at a value equal

* Department of Anesthesiology, Tufts University School of Medicine, New England Center Hospital, and Boston Floating Hospital for Infants and Children, Boston.

to the normal resting spontaneous inspiratory flow for the size of the infant. For inspiration, a relay valve intermittently closes the expiratory limb of the Y tube. This permits the flow of anesthetic gases to enter the patient's respiratory system for the duration of the closure of the expiratory limb. As soon as this valve opens, expiration is initiated. This permits the expired gas and the excess flow from the anesthesia machine to escape via the open limb of the Y tube. This opening and closing of the valve is automatically controlled by two switches on the control unit. One switch energizes the duration of inspiration and the other the duration of expiration. The control of the respiratory frequency and the inspiration/expiration ratio is obtained by changes in these settings. The respiratory frequency is determined by the equation:

$$f = \frac{60 \text{ sec.}}{\text{insp.} + \text{exp. time in sec./cycle}} = \text{frequency in cycles/min.}$$

Inspiratory time can be adjusted between 0.2–1.2 seconds; expiratory time can be adjusted between 0.5–3.0 seconds.

The tidal volume is determined by either adjusting the duration of closure of the relay valve or by altering the flow rate of gases from the anesthetic machine. This dual control of tidal volume is advantageous because

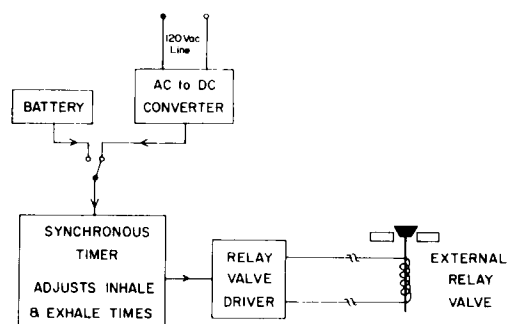
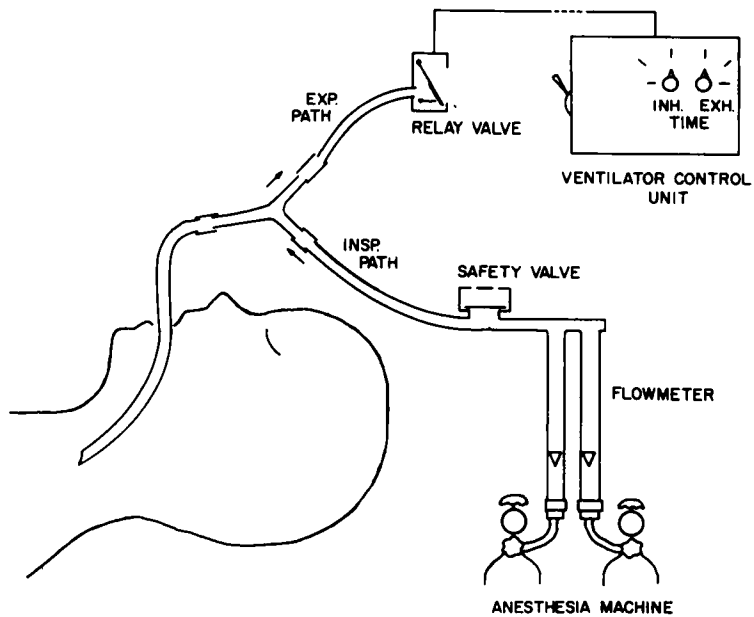

FIG. 1. Block diagram of electronic circuit of infant ventilator.

FIG. 2. Schematic diagram of ventilator.



the anesthetist may obtain a desired tidal volume by either a high gas flow of short duration or by a low flow of longer duration (fig. 3). The former is desirable in patients with a low blood volume because it minimizes mean airway pressure. A low flow of gases of longer duration during inspiration is advantageous in normal patients and particularly in

patients with bronchospasm or tracheal obstruction for the following reasons: (1) it minimizes the flow resistive element of lung thorax expansion; (2) it promotes a more equal alveolar distribution of the inspired gas,¹ particularly when the time constants of various pulmonary segments vary; (3) physiologic dead space is reduced.²

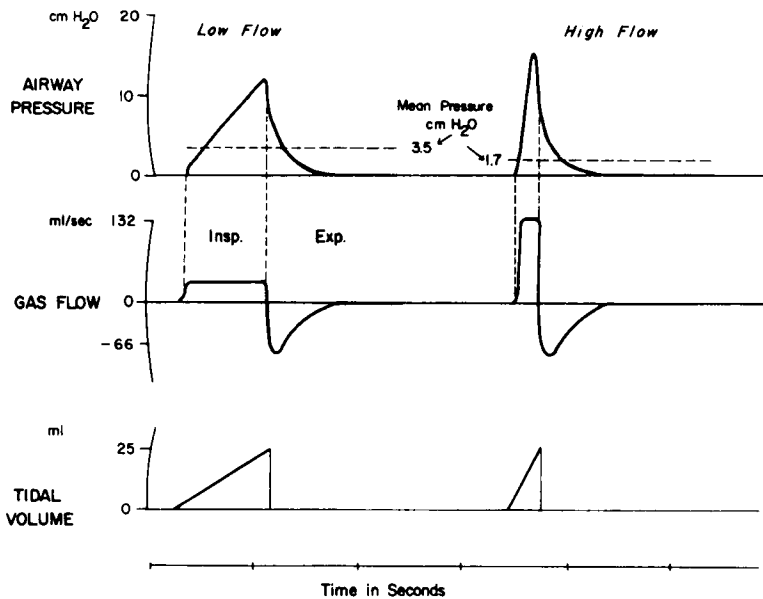

FIG. 3. Actual recording of pressure-flow volume relations in a 4.0 kg. infant to illustrate the dual control of tidal volume with the infant respirator.

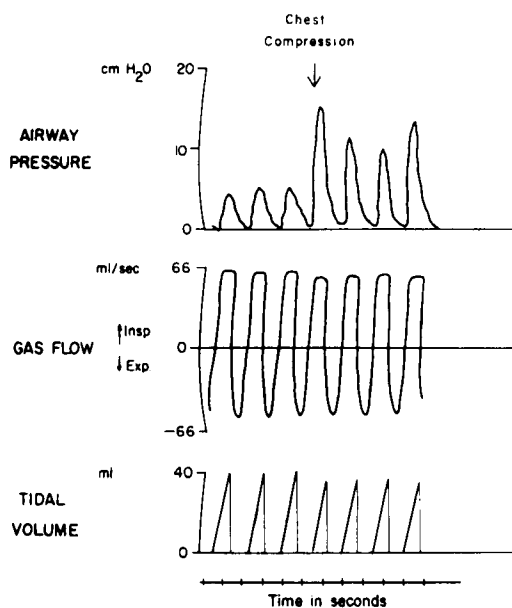

FIG. 4. Recording of pressure-flow-volume relations in a 2.5 kg. cat to illustrate the effect of decreasing compliance on gas flow and tidal volume.

Because the inspiratory flow rate is constant, the tidal volume can be calculated by the following equation:

$$V_T = \text{insp. time (sec.)} \times \text{flow (ml./sec.)} \\ = \text{tidal volume in ml.}$$

The ability to calculate the tidal volume depends upon the accuracy of the flow meters and the absence of leaks in the system. The tidal volume as predicted by the Radford nomogram is adequate for infants with essentially normal cardio-pulmonary function. The respiratory minute volume can be adjusted properly only by obtaining arterial blood gas concentrations in patients with congenital heart defects or pulmonary disease.

The expiration time can be controlled in patients with prolonged pulmonary emptying due to bronchospasm, vascular ring or other obstructions by simple adjustment of the ventilator controls. This maneuver permits a complete expiration phase before subsequent inspiration, thereby avoiding the gradual hy-

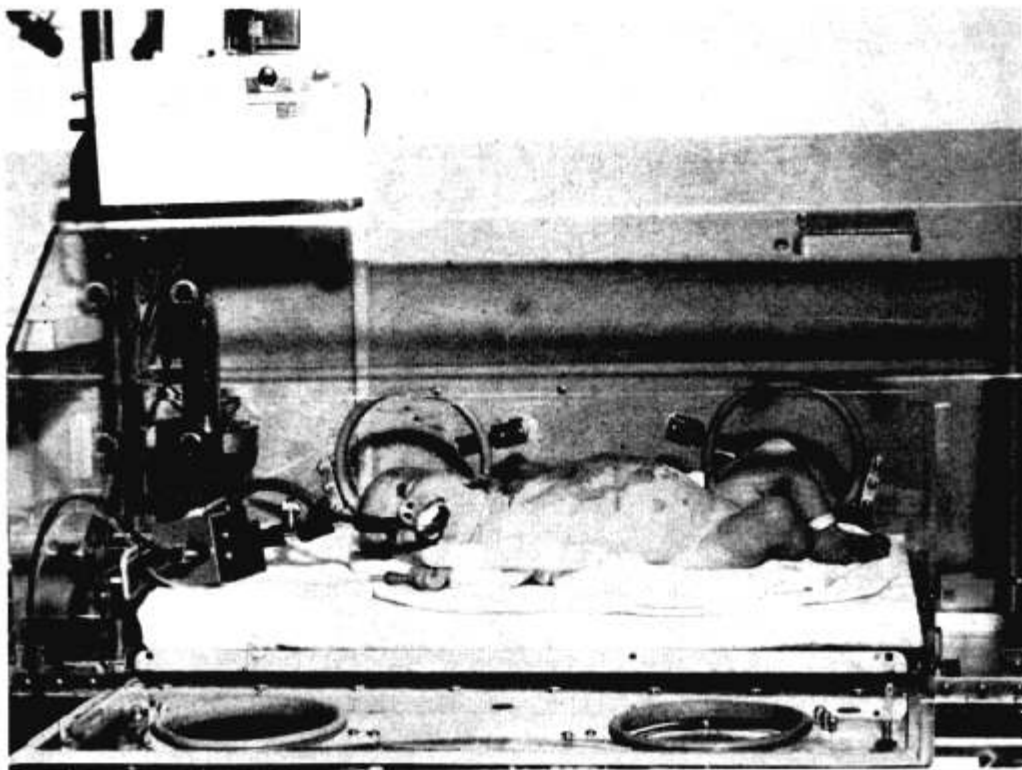

FIG. 5. Photograph of ventilator inside an incubator. The control unit is on top of the incubator.

perinflation of the lungs which frequently occurs with rapid respiratory frequencies in such patients.

This ventilator delivers a tidal volume which is not altered significantly in the presence of a sudden decrease in compliance or a moderate increase in airway resistance, as shown by studies in this laboratory. Figure 4 illustrates a typical experiment. When the chest was intentionally compressed to reduce the compliance by approximately 50 per cent, the gas flow and tidal volume were decreased less than 10 per cent.

A safety valve that will blow off at an adjustable predetermined pressure is incorporated in the ventilator. This feature avoids the possibility of overdilatation of the lungs due to electronic failure causing the valve to remain in the closed position. Airway pressures as high as 100 cm. of water can be developed, however, when necessary, as in certain infants with hyaline membrane disease. A visual or auditory signal indicates electronic failure in either the open or closed position of the valve. A pressure gauge is included in the system

to determine the peak airway pressure which is a function of airway resistance and lung thorax inflation.

SUMMARY

A ventilator of simple electrical and mechanical construction was designed for use in physiologically controlling respiration in infants during and after surgical anesthesia. The apparatus is portable, can be used in the presence of explosive agents and can be easily placed on the operating table beside the head of the patient or inside an isolette (fig. 5).

This work was supported by USPHS Grant HE-0-4645-04. Oliver Morse, M.S.E.E., and Fritz Klein, M.S.E.E., were responsible for the electronic aspects of the ventilator.

REFERENCES

1. Spalding, J. M. K., and Crampton Smith, A.: *Clinical Practice and Physiology of Artificial Respiration*. Philadelphia, F. A. Davis Co., 1963, pp. 50-51.
2. Watson, W. E.: Observations on physiological dead space during intermittent positive pressure respiration, *Brit. J. Anaesth.* **34**: 504, 1962.

Modified Head for Standard Intravenous Pole

GERALD SHAPIRO, M.D.*

To facilitate management of multiple solutions during anesthesia, a standard intravenous pole was modified to have six prongs instead of the usual pair. The pole, which is com-

mercially available, is arranged so that the head swivels. In addition, the base is weighted to accommodate the extra weight on the prongs as well as the distribution of that weight and a friction lock is used to facilitate one-handed control of height.

* Knickerbocker Hospital, New York City.