

## Effect of Altered Resistive Load on Left Ventricular Systolic Mechanics in Dogs

R. M. Prewitt, M.D.,\* and L. D. H. Wood, M.D.†

The authors tested the possibility that end-systolic volume is reduced at a given aortic and left ventricular (LV) pressure when systemic vascular resistance is reduced. In seven anesthetized dogs pretreated with propranolol to block reflex changes in contractility, the authors measured aortic pressure and ventricular volumes under baseline conditions and after reducing resistive load by opening two peripheral arterio-venous shunts. When resistive load was reduced, blood pressure was maintained with plasma volume expansion. Real size biplane ventricular end-diastolic areas were obtained using scintigraphic techniques and end-diastolic volumes were calculated using the area-length equation. Thermodilution stroke volume was subtracted from end-diastolic volume to obtain end-systolic volume. When resistive load decreased, mean ejection rate doubled ( $P < 0.01$ ) and left ventricular end-systolic volume decreased ( $P < 0.005$ ) despite constant aortic pressure. In seven additional dogs, pretreated with propranolol, the authors measured left ventricular pressure, instantaneous and peak left ventricular flow before and after resistive load was reduced by opening one shunt. Despite constant left ventricular pressures, instantaneous, peak and total flow increased when resistance was reduced. It was concluded that the left ventricle shortens farther and faster during ejection against the same aortic and LV pressure when resistive afterload is reduced. (Key words: Arterio-venous shunt. Systolic mechanics. Vasodilator therapy. Ventricular pressure-volume curves.)

VASODILATOR THERAPY increases stroke volume and reduces the size of failing hearts.<sup>1,2</sup> The associated increase in cardiac output maintains blood pressure despite peripheral vascular dilation, so these cardiovascular effects are attributed to reduced viscous or resistive load. To the extent that ventricular end-diastolic volume does not increase during vasodilator therapy,<sup>3</sup> these results suggest that end-systolic volume is reduced at similar aortic and ventricular pressures when resistance is reduced. However, recent studies of ventricular mechanics emphasize that for a given contractile state the instantaneous and end-systolic left ventricular pressures are the sole determinants of the corresponding ventricular volumes.<sup>4-6</sup> This study was designed to test the possibility that for a given contractile state and left ventricular and aortic pressure corresponding ventricular volumes are reduced when resistive afterload is less.

\* Scholar of the Great West Life Assurance Co.

† Scholar of the Canadian Life Insurance Association.

Received from the Section of Respiratory Diseases and Section of Cardiology, Department of Medicine, University of Manitoba, Winnipeg, Manitoba, Canada. Accepted for publication September 11, 1981. Supported by the Medical Research Council of Canada and the Manitoba Heart Foundation.

Address reprint requests to Dr. R. M. Prewitt: Health Sciences Centre, F222- 700 William Avenue, Winnipeg, Manitoba, R3E 0Z3 Canada.

### Methods

We modified and studied a canine model in which opening a systemic arterio-venous shunt doubled cardiac output at the same blood pressure even when cardiovascular reflexes were blocked.<sup>7</sup> In the first set of experiments, left ventricular end-diastolic volume (LVEDV) was measured by nuclear cardiology techniques, and end-systolic volume (LVESV) was calculated by subtracting stroke volume (SV) obtained by thermal dilution. Pulmonary capillary wedge pressure (PCWP) reflected left ventricular filling pressure and the aortic pressure at the incisura immediately preceding the aortic valve was taken to reflect the aortic end-systolic pressures. All measurements were obtained during four successive experimental conditions: 1) baseline, 2) five minutes after opening the arterio-venous shunt, 3) following plasma volume expansion (approximately 300 ml of 6 per cent Dextran) with the shunt open, and 4) five minutes after closing the shunt. We reasoned that if aortic or left ventricular end-systolic pressure were the sole determinant of end-systolic volume, opening the shunt (conditions 2 and 3) would not change the end-systolic V-P relationship defined in conditions 1 and 4. To prevent reflex changes in contractility from affecting our results, cardiogenic reflexes were blocked with propranolol (1.5 mg/kg) at the beginning of the experiment.<sup>8</sup> The effectiveness of the block was tested by infusing isoproterenol at 6  $\mu\text{g}/\text{min}$  for 3 minutes. Before propranolol, isoproterenol infusion increased mean heart rate from 140 to 221 beats/min. After blockade, heart rate did not change. The failure of heart rate to increase with isoproterenol was confirmed at the end of each experiment.

Seven mongrel dogs (18-33 kg) were anesthetized with pentobarbital (30 mg/kg) laid supine and artificially ventilated (20 ml/kg) via an endotracheal tube with room air. The dogs did not require or receive additional anesthesia. Peripheral arterio-venous shunts were constructed by inserting short (10 cm) wide bore (ID 4 mm) polyethylene catheters in the right and left femoral arteries. These were connected by flexible rubber tubing to a longer polyethylene catheter which was inserted in the femoral vein and advanced to the thoracic inferior vena cava. Both shunts were opened and closed with forceps. A Millar, transducer-tipped catheter was introduced via the left common carotid artery into the thoracic aorta and its output displayed on a six-channel Hewlett Packard® oscillograph. Measurements of systemic blood

pressure (BP) were obtained from this catheter. A thermistor-tipped Swan-Ganz catheter was inserted via the external jugular vein and positioned by means of pressure monitoring in a branch of the pulmonary artery where pulmonary artery pressure (PAP) was obtained. Pulmonary capillary wedge pressure (PCWP) was obtained via this catheter by inflating its balloon. A second catheter was positioned in the right atrium to measure right atrial pressure (RAP). All pressures were referenced to the center of the chest. Both catheters were connected to Statham® P23 BB transducers and transducer outputs were displayed on the oscillograph. A third catheter was also positioned in the right atrium for injection of saline boluses during cardiac output (CO) determinations (Columbus Instruments).

We tested our complete thermal dilution technique in a bench model over a wide range (0.8–8.0 l/min) of pulsatile flow of warm (37°C) saline through distensible tubing (ID 1.5 cm). A mixing chamber was interposed between the injection and sampling ports of the catheter. Reproducibility at each flow was excellent and the thermal dilution cardiac output accurately estimated the true flow over the whole flow range studied. Stroke volume (SV) was obtained by dividing cardiac output by the heart rate. Systemic vascular resistance was calculated according to the equation  $SVR = (BP - RAP)/Co$ . Mean LV ejection rate ( $\bar{v}$ ) was obtained by dividing SV by ejection time (ml/s). Ejection time was taken as the time from the systolic rise in aortic pressure to end-systolic pressure (aortic valve closure indicated by the incisura). Further, to take account of the effects of preload on velocity of ejection, mean ejection rate in the different experimental conditions was normalized by dividing by EDV.<sup>5</sup> This normalized rate has a dimension of  $s^{-1}$ .

Biplane left ventricular end-diastolic images were obtained under each of the experimental conditions using equilibrium nuclear cardiology techniques. Ten milligrams of the reducing agent stannous pyrophosphate was injected intravenously. Five minutes later 40 mCi of technetium was injected intravenously and this was bound to the reduced red blood cells. When the labeled cells were uniformly distributed in the blood, a mobile gamma camera (Picker) equipped with a parallel hole collimator, was oriented in the left anterior oblique position (LAO), where the interventricular septum was clearly visible on the oscilloscope display of the blood pool in the heart. The gamma camera contains a cardiac (computer) module which gates the camera to R-wave of the QRS complex, and automatically divides the R-R interval of each cycle into 12 equal time segments. Gated recordings of four to five hundred cardiac cycles gave sufficient counts to produce high resolution images at each of the 12 specific points. Recording time in LAO position was approximately three minutes. Following completion of im-

aging the gated study was displayed in the form of hard copy photographic images. Following imaging in the LAO position the camera head was rotated 90° with care taken to maintain the same coronal and saggittal planes, and imaging begun in the right anterior oblique position. Ten to 15 measurements of cardiac output and heart rate were obtained during imaging in each projection. Two to three measurements of RAP and PCWP were obtained, also. PAP and aortic pressure were recorded continuously, and mean aortic pressure was periodically obtained by using an electronic averaging circuit.

After completion of the entire study ventricular images obtained in RAO and LAO projections were separated. Left ventricular perimeters at end diastole were determined by tracing around the edge of the left ventricle with a felt pen. This last procedure was performed blind, in that the experimental condition corresponding to that end diastolic image was unknown. Separation of left atrium from left ventricle in both projections was aided by reference to first pass flow studies recorded in one projection in each study. Using a calibration source the outlined images were expanded to real size and left ventricular areas were determined by planimetry. Then, end-diastolic volumes were determined by the formula of Dodge *et al.*<sup>9</sup> As previously discussed LVESV was determined by subtracting SV from EDV. ESV was not obtained from gated images because the gamma camera only divided the R-R interval into 12 equal time segments and corresponding images. Accordingly, no image accurately reflected end-systolic area. Also, at end systole a greater proportion of the area is occupied by papillary muscles and chordae.

We were concerned that left ventricular end-systolic pressure might be overestimated by aortic dirotic notch pressure.<sup>10</sup> Because of this possibility and to determine the effects of opening an arterio-venous (a-v) fistula on instantaneous LV pressure and flow in seven additional experiments we measured simultaneous aortic flow and aortic and left ventricular pressures. The dogs were prepared and studied in the manner described previously except that a thoracotomy was performed to place an electromagnetic flow probe around the aorta between the aortic valve and the innominate artery. Measurements were obtained in control conditions (A) and after opening one shunt (B). Millar catheter-tipped pressure-transducers were positioned under fluoroscopy in the left ventricle and in the aorta adjacent to the aortic valve. Simultaneous pressures and flows were recorded on the oscillograph before and after resistance was reduced. These experiments were designed to maintain aortic and LV systolic pressure when shunt was open and resistance reduced. Accordingly, only one shunt was opened and when LV systolic pressure fell below control levels small amounts of volume (100–200 ml of 6 per cent Dextran)

were given to increase systolic pressure. In these experiments LVESP was picked at the point of zero flow. Left ventricular volumes were not measured in the dogs.

Results were tested for significance using the Student's paired *t* test.

### Results

Table 1 summarizes the mean ( $\pm$ SD) hemodynamic effects of opening an arterio-venous shunt in the seven dogs without thoracotomy and flow probe. Between baseline and condition 2, cardiac output and stroke volume increased by about 75 per cent ( $P < 0.01$ ) with no corresponding changes in ventricular filling pressures or left ventricular end-diastolic volume. Accordingly, end-systolic volume decreased ( $P < 0.005$ ) from 28 ml to 18 ml upon opening the shunts, and mean ejection rate increased by 50 per cent ( $P < 0.01$ ). Ejection rate increased because SV increased and ejection time remained constant. These changes were associated with only a 7 per cent reduction in mean blood pressure and aortic end-systolic pressure, but systemic vascular resistance decreased by about 50 per cent when the shunt was opened ( $P < 0.01$ ).

Following plasma volume expansion (approximately 300 ml of 6 per cent Dextran), blood pressure, cardiac output, stroke volume, PCWP, and end-diastolic volumes increased. Note that end-systolic volume did not increase, so LVESV is lower in condition 3 than condition 1 even

though mean aortic end-systolic pressure in condition 3 ( $140 \pm 13.2$ ) exceeds ( $P < 0.05$ ) that in condition 1 ( $131 \pm 17.2$ ). Furthermore, the normalized ejection rate remains higher in condition 3 than condition 1. When the shunt was closed again in condition 4, cardiac output and stroke volume decreased ( $P < 0.01$ ), associated with a large increase in end-systolic volume (17.8 to 39 ml), and a large reduction in ejection rate ( $P < 0.01$ ). Blood pressure and aortic ESP increased about 10 per cent when the shunt was closed, and systemic vascular resistance increased 70 per cent ( $P < 0.001$ ).

Figure 1 plots the mean end-diastolic and end-systolic volumes for the six experiments in which measurements were obtained in all four numbered conditions (*e.g.*, in one experiment measurements were not obtained in condition 2 and data from this dog is not included in figure 1). In all experiments, acute plasma volume expansion (condition 2 to 3) increased both EDV and PCWP, conforming to a diastolic volume-pressure curve with a positive slope. As indicated by the continuous systolic volume-pressure line connecting 1 and 4, end-systolic volume increased in all dogs as aortic pressure increased in the absence of shunts. Compared to condition 1, opening the shunt (condition 2) did not change LVEDV but did increase stroke volume because LVESV decreased. After plasma volume expansion (condition 3), mean aortic ESP lies between the values for condition 1 and 4, yet mean LVESV is much less than both shunt closed conditions. Compared to condition 1, LVESV is reduced

TABLE 1. Effects of Altered Resistive Load on Hemodynamics and Ventricular Mechanics

	Baseline (1)	Shunt Open (2)	Shunt Open Plus Volume (3)	Shunt Closed (4)
CO (l/min)	2.1 $\pm$ .7	3.5 $\pm$ .7	4.7 $\pm$ 1.4	3.0 $\pm$ .9
HR (min. <sup>-1</sup> )	143 $\pm$ 17	143 $\pm$ 18	142 $\pm$ 17	142 $\pm$ 17
RAP (mmHg)	2.5 $\pm$ .7	2.1 $\pm$ 1.6	3.1 $\pm$ 1.1	2.3 $\pm$ 2.0
PCWP (mmHg)	8.7 $\pm$ 2.6	8.0 $\pm$ 2.1	12.1 $\pm$ 5.9	9.3 $\pm$ 4.2
EDV (ml)	43 $\pm$ 7.5	43 $\pm$ 9.8	52 $\pm$ 11.2	58 $\pm$ 11.3
SV (ml)	14.7 $\pm$ 4.3	24.4 $\pm$ 7	33 $\pm$ 12	21 $\pm$ 7
BP (mmHg)	134 $\pm$ 15	123 $\pm$ 18	139 $\pm$ 15	153 $\pm$ 22
ESP (mmHg)	131 $\pm$ 17.2	123 $\pm$ 18	140 $\pm$ 13.2	153 $\pm$ 17
ESV (ml)	28 $\pm$ 8.3	18 $\pm$ 10.3	17.8 $\pm$ 11.3	39 $\pm$ 7.8
SVR (mmHg $\cdot$ l <sup>-1</sup> $\cdot$ min)	65 $\pm$ 15	36 $\pm$ 9	31 $\pm$ 9	54 $\pm$ 17
$\bar{v}$ (ml/s)	108 $\pm$ 18	164 $\pm$ 40	206 $\pm$ 36	132 $\pm$ 13.5
$\bar{v}$ /EDV (s <sup>-1</sup> )	2.5 $\pm$ .4	3.8 $\pm$ .9	4 $\pm$ .7	2.3 $\pm$ .2

Values are means  $\pm$  SD.

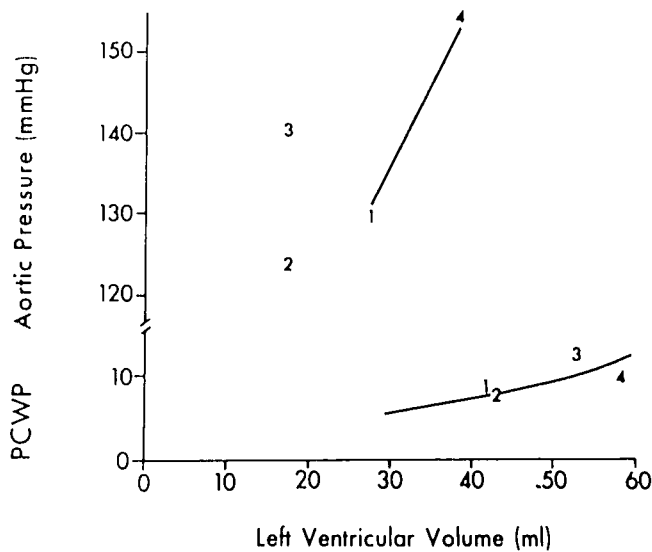

FIG. 1. Effect of reduced resistive load on left ventricular volume (abscissa, ml)-aortic-PCWP pressure (ordinate, mmHg) relationships. The numbers denote the four sequential experimental conditions, and indicate the mean pressure-volume coordinates for the six dogs in which measurements were obtained in all conditions. Stroke volume is the difference between diastolic and systolic values for each condition. The end-diastolic values in the lower right do not obviously depart from a single curve. The end-systolic coordinates with closed shunts (1-4) demonstrated that ESV increases from 1 to 4 (continuous lines) in our experiments. Note that the corresponding coordinate with open shunts (2 and 3) are displaced to the left of the continuous lines, indicating reduced end-systolic volume at a given end-systolic pressure.

significantly in condition 3 despite increased pressure. Note that when the shunt was closed again (condition 4), stroke volume was halved despite a slightly larger LVEDV because LVESV increased markedly from condition 3 (18 ml) to condition 4 (39 ml).

These results demonstrate that opening a systemic shunt increases stroke volume by reducing end-systolic volume even when mean aortic and aortic ESP is increased.

Table 2 summarizes the mean hemodynamic effects of opening one a-v shunt in the seven dogs with thoracotomy and flow probe. Opening one shunt caused a large increase in CO and SV ( $P < 0.05$ ). Left and right ventricular EDPs did not change indicating constant preload, as documented in the previous experiments. Accordingly, since aortic and left ventricular pressures remained constant the increased SV is explained by the reduction in resistive load ( $P < 0.005$ ) and ESV. Despite constant ESP, ESV was reduced in B because LVEDP (EDV) was similar in A and B but SV increased in B. Accordingly, despite a constant end-systolic pressure extent of ventricular shortening increased and ESV was reduced when resistive load was less. Opening a shunt increased SV and reduced LVESV because LV ejection rate increased. As indicated in Table 2 mean peak ejection

rate increased from 242 ml/s to 308 ml/s ( $P < 0.05$ ) when resistive load was reduced. Also, instantaneous rate increased in B despite similar aortic and LV pressures. Accordingly, instantaneous LV P-V ratio was increased in B. These features are illustrated in figure 2. Note the similar values of LV and aortic pressures in A and B. Therefore, LV ejection rate and stroke volume increased when resistance was reduced even when LV and aortic pressures did not change.

## Discussion

When a systemic arterio-venous shunt is opened in dogs with blocked cardiovascular reflexes, cardiac output and stroke volume increase because the resistance to venous return is reduced.<sup>7</sup> Increased CO and SV could be due to increased end-diastolic or reduced end-systolic volume. Our results extend these findings by describing how the heart increases stroke volume to accommodate the greater venous return. Rather than increasing end-diastolic volume, the left ventricle reduced end-systolic volume when the shunt was opened, and increased it again when the shunt was closed. Of special interest is the observation that reduced LVESV occurred at the same or increased aortic and LV end-systolic pressure when systemic vascular resistance was reduced.

In our first series of experiments (fig. 1), condition 4 differs from condition 1 by an acute intravenous Dextran load prospectively designed to describe end-diastolic and end-systolic V-P relations of the canine left ventricle when the resistive load is normal. We contend that lines properly controls for any effects on the normally loaded ventricle of time or of opening and closing the a-v shunts

TABLE 2. Effects of Reduced Resistance Afterload on LV Performance

	Baseline (A)	Shunt Open (B)
CO (l/min)	1.58 ± .5	2.47 ± .6
RVEDP (mmHg)	4.5 ± 3	5.9 ± 3.9
LVEDP (mmHg)	12.3 ± 2	11.9 ± 2.2
SV (ml)	12.7 ± 4.5	18.4 ± 5.9
BP (mmHg)	96 ± 11.9	98 ± 10.6
LVESP (mmHg)	82 ± 9.3	82 ± 10
SVR (mmHg·l <sup>-1</sup> ·min)	76 ± 21	50 ± 9
Peak V (ml/s)	242 ± 71	308 ± 81
BP diastolic (mmHg)	92 ± 16	86 ± 14

Values are means ± SD.

FIG. 2. Photograph of recordings where left ventricular and aortic pressures and aortic flows were recorded against time before (A) and after (B) resistance was reduced. Note the similar left ventricular and aortic pressures and similar ejection times. Left ventricular end-diastolic and end-systolic pressures are identical in both conditions. Despite similar LV systolic pressures, flow is increased when resistance is reduced. Because pressures are similar in A and B and instantaneous and total flow increased in B the instantaneous LV P-V ratio is increased in B and ESV is reduced. For further discussion, see text.

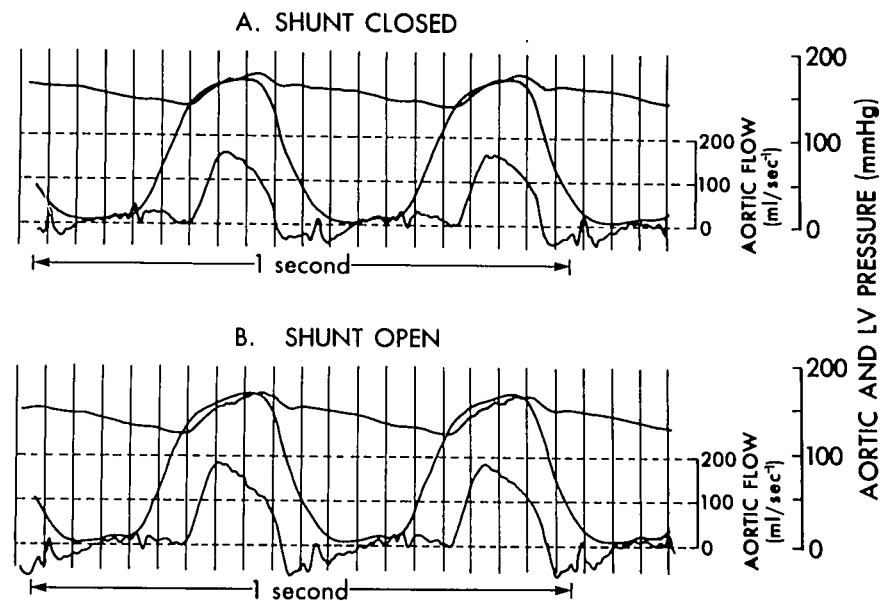

to obtain the intervening measurements at reduced resistive load. Volume loading and increased LVEDV *per se* either does not affect end-systolic V-P relations<sup>4</sup> or increases LVESV at the same pressure afterload.<sup>11</sup> Such an effect would increase LVESV in condition 3 compared to condition 1, yet our major finding was just the opposite—in all experiments LVESV was less in condition 3 when resistive load was reduced than in condition 1 despite its lower pressure afterload. We conclude that altered resistive load has a unique effect on LVESV when pressure afterload is unchanged.

Note that those who believe *a priori* that resistive load has no effect on end-systolic V-P relations may argue that lines connecting condition 1 with 2 and condition 3 with 4 in figure 1 are just as plausible as the end-systolic V-P line we constructed between 1 and 4. This would give two parallel “contractility” lines—*e.g.*, 1, 2 and 3, 4—each with a positive slope and separated vertically by volume loading between condition 2 and 3. Using such lines it is not possible to determine whether resistive load has a unique effect on end-systolic V-P relations for reduced LVESP between 1 and 2 is associated with reduced resistive load, and increased LVESP between 3 and 4 is associated with increased resistive load. Note further that such arbitrary lines 1, 2 and 3, 4 have low slopes and pressure intercepts at zero LVESV (100 mmHg) which are well outside the reported range for these values, yet the line connecting condition 1 and 4 has a slope and intercept consistent with values in the literature.<sup>4,5</sup> We conclude that interpretation of end-systolic V-P relationships to indicate ventricular contractility when both resistive and pressure afterload change is erroneous because altered resistive load has a separate and unique effect on the end-systolic V-P relationship.

The second series of experiments confirmed that instantaneous aortic flow increased throughout ventricular ejection against increased left ventricular pressure when the a-v shunt was opened. They further confirmed that stroke volume increased when LVESP and LVEDP did not change with reduced resistive load between conditions A and B. Because opening the a-v shunts did not alter LV diastolic V-P relations or change LVEDV and PCWP between conditions 1 and 2 in the first series, we consider it likely that LVEDV did not change between A and B in the second series when LVEDP did not change. Note that this conclusion does *not* assume that thoracotomy in the second series has no effect on diastolic mechanics, but that opening the shunt has no effect on diastolic mechanics in the second series with thoracotomy as was demonstrated in the first series without thoracotomy. Accordingly, stroke volume increased at the same LVEDV and LVESP when the shunt was opened in the second series. The results confirm that LVESV is reduced at the same LVESP when resistive load is reduced as demonstrated in the first series when the ventricular volumes but not the true ventricular pressures were measured.

Biplane cine angiography is a technique widely used to obtain ventricular volumes.<sup>9,12</sup> Several groups used scintigraphic techniques to obtain LV end-diastolic and end-systolic images.<sup>13,14</sup> Volumes were obtained according to the area-length formula, and LV ejection fractions were calculated. There was excellent agreement between ejection fractions and ventricular volumes calculated this way and those according to standard angiographic techniques. Given adequate measurements of the change in ventricular volumes and the corresponding pressures in our two series of experiments, we conclude that rate and

extent of LV shortening increases when the resistive load on the ejecting ventricle is reduced. It follows that instantaneous and left ventricular end-systolic volume are not determined uniquely by aortic or LV pressure in intact animals when the systemic vascular resistance is altered.

This appears to conflict with the conclusions of two groups of investigators who studied left ventricular mechanics in isolated perfused canine hearts. Sagawa and colleagues<sup>4,5,15</sup> observed that end-systolic volume increased when the pressure was raised in the chamber into which the left ventricle ejected (as along the continuous line connecting coordinates 1 and 4 in fig. 1), and that this systolic pressure-volume relationship became displaced to the left (coordinate 3, fig. 1) when the contractile state was increased with isoproterenol or calcium infusions. Also, they noted that the instantaneous P-V ratio increased with a positive inotropic intervention.<sup>15</sup> Weber's group have presented convincing arguments that left ventricular force is a more complete description of ventricular load than is LV pressure.<sup>16-18</sup> They concluded that end-systolic force is related to end-systolic volume and instantaneous force is related to corresponding ejection rate. Note that end-systolic force as calculated by Weber<sup>17,18</sup> is proportional to the end-systolic volume-pressure product, so transforming the end-systolic pressure of figure 1 or table 2 to force would not obviate the differences in LVESV at the same end-systolic load when resistance was reduced. According to these concepts, our data suggest that opening a shunt increases contractility.

However, reflex changes in ventricular contractility are unlikely in propranolol-blocked dogs.<sup>8,19</sup> Conceivably, reduced diastolic aortic pressure when the shunt was open (see table 2) explains our data. A lower pressure at onset of ejection would, for a constant ventricular volume, result in a reduction in wall force which would tend to increase ejection rate. Yet, Suga *et al.*<sup>5</sup> (fig. 6 panel A, of their paper) demonstrated that the LV end-systolic P-V coordinate remained constant despite variation in initial ejection pressure. Accordingly, while the small reduction in diastolic pressure in B might contribute to the enhanced performance, we believe the increased rate and extent of ejection is predominantly due to the reduction in resistive load, and suggest that this conclusion does not conflict with the studies of Sagawa *et al.* and Weber *et al.*

Note that the isolated heart observations were obtained during LV ejection through a large diameter rigid out-flow tube in which the cross-sectional area and, thus, resistive afterload was relatively constant. Accordingly, their conclusions may not apply to the experimental condition in which resistive afterload was varied independent of aortic and LV pressure. Conceivably, the major reduction in resistance in our study represented a reduction

in the total mechanical load impeding ejection and allowed the ventricle to eject further and faster against the same pressure load, a possibility not excluded by earlier studies<sup>5,17-19</sup> where only pressure load was altered. This possibility is consistent with classical mechanical theory which states that when a systolic pressure or force is applied by the ventricle to the blood, equal opposing loads develop having capacitative, resistive and inertial components proportional to aortic wall displacement, blood velocity, and blood acceleration, respectively.<sup>20</sup> Indeed, several studies demonstrated that capacitative and resistive impedance have independent effects on ventricular ejection<sup>21-23</sup> and on the rate of isolated myocardial shortening.<sup>24,25</sup> Although each of these studies demonstrated an important effect of altered resistive loading on systolic performance, none compared directly the effect of altered resistive loads at constant aortic and LV pressure on rate and extent of ejection. The results of the present study confirm and extend these studies by demonstrating that reduced resistive afterload is associated with increased ejection rate, increased instantaneous LV

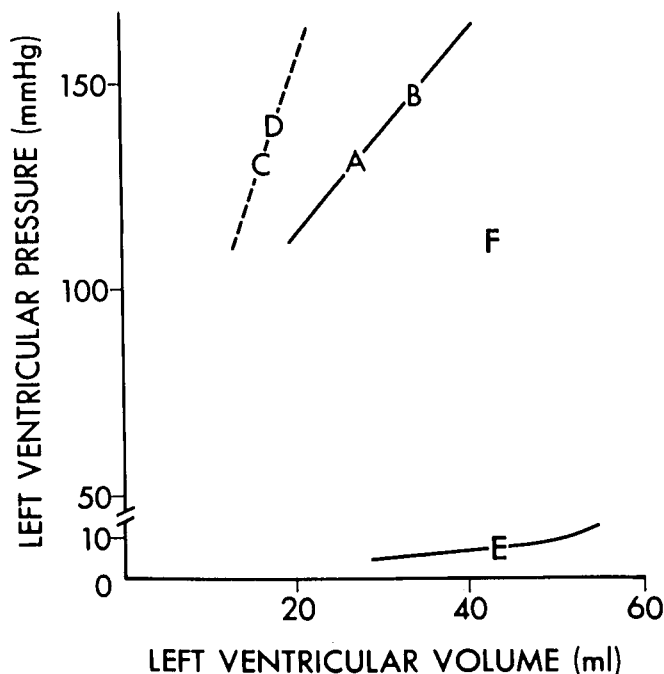

FIG. 3. Schematic left ventricular diastolic and systolic volume-pressure curves. Axes as in figure 1. If the systolic V-P curve through A-B represent baseline data for a single contractile state, the steeper V-P curve through C-D is displaced to the left of A-B, representing increased contractility. Note the similarity to our mean data in figure 1 where contractility is probably constant but resistive afterload is reduced. For the same LVEDV for both closed and open shunt conditions given by E on the diastolic curve, isovolemic systole proceeds to F where the aortic valve opens. Then LV ejection proceeds to point A with shunts closed. When the shunts are open, LV shortens faster and farther to C despite the same pressure afterload.

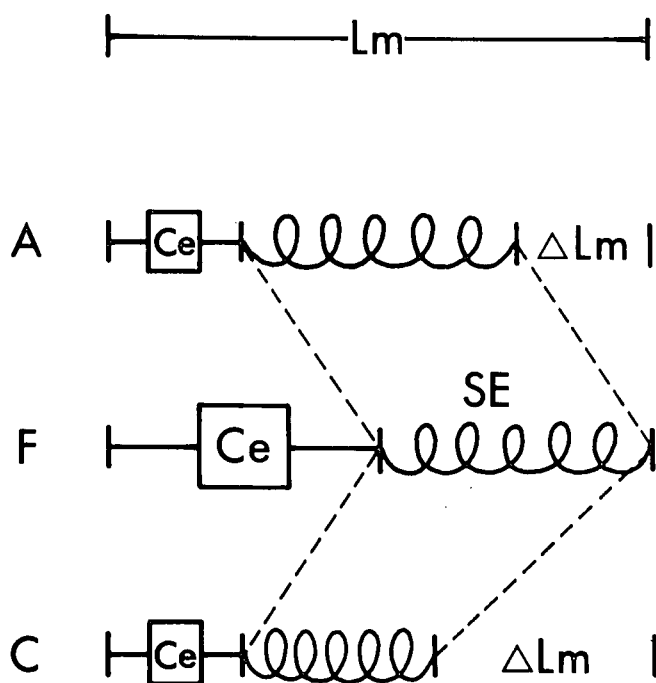

FIG. 4. Effect of reduced systemic vascular resistance on a Hill muscle model in which  $v_{ce}$  is not allowed to change. Panel F depicts the total muscle length ( $L_m$ ) at the end of isovolemic systole for shunt closed and shunt open conditions, and corresponds to F in figure 3. The contractile element (Ce) has shortened at velocity  $v_{ce}$  between end diastole (E in figure 3) and F, stretching the series elastic element (SE) to increase pressure without changing  $L_m$ . Panel A depicts the shorter  $L_m$  and shorter ce corresponding to end ejection when the shunt was closed (F to A in figure 3). If  $v_{ce}$  is equal to the velocity of muscle shortening, the length of SE does not change. Panel C depicts an even shorter  $L_m$  at end ejection when the shunt was open (F to C in figure 3). The length of CE is the same in C as in A because the ejection time and  $v_{ce}$  are the same. Accordingly, the greater velocity and extent of muscle shortening is due to SE which shortened during LV ejection against the reduced resistive afterload.

P-V ratio, and reduced end-systolic volume at the same or increased aortic and LV pressure.

Further examination of the data in tables 1 and 2 highlight interesting aspects of this association. Since PCWP and LVEDV are similar in conditions 1 and 2 (and also in conditions 3 and 4), end-diastolic wall force or preload is similar. Yet ejection velocity is greater in conditions 2 and 3, and end-systolic wall force, or afterload, is less in conditions 2 and 3 (smaller LVESV and LVESP than conditions 1 and 4, respectively). We are left with explaining how the ventricle with similar preloads became associated with lesser afterloads by ejecting faster and farther in conditions 2 and 3 when only resistive load was reduced. To the extent that reduced resistive load caused these changes in ventricular pumping performance, two complementary mechanisms might be involved as illustrated in figures 3, 4, and 5. In figure 3, consider isovolumic systole beginning from the same

end-diastolic volume and pressure, E, and proceeding to point F at the same velocity of the contractile element ( $v_{ce}$ ). When the shunt is closed, ejection proceeds from F to A at a rate proportional to  $v_{ce}$ . This is schematically illustrated in the Hill muscle model<sup>26</sup> in figure 4, in which the series elastic element is kept arbitrarily at the same length between F and A, so the muscle shortens ( $L_M$ ) by the amount of contractile element shortening. To the extent that  $v_{ce}$  does not change when the shunt is opened, the myocardium could shorten faster and farther (F to C in figs. 3 and 4) if the series elastic element is stretched less during ejection against the reduced resistive afterload. This is illustrated in figure 4 by the shorter series elastic element in C than in A, so the muscle shortened more during the same ejection time. The alternative or complementary mechanism is depicted in figure 5. When the shunt was open, velocity was higher and systemic vascular resistance was reduced, so ventricular and aortic pressures were similar to the shunt closed values (see figure 1). Yet left ventricular volume is smaller from the onset of ejection when the shunt is open, as illustrated in the left panel of figure 5. Accordingly, ventricular force (proportional to the volume-pressure product) is also reduced throughout ventricular ejection against the reduced resistive load, and  $v_{ce}$  will increase along the force-velocity diagram<sup>19,25</sup> in the right panel of figure 5.

### Acknowledgments

The authors are grateful for the assistance of the following people: Dr. Luis Oppenheimer for placement of aortic flow probes; Drs. How-

$$\text{LOAD} = \Delta V/C + \dot{V}R + \ddot{V}L$$

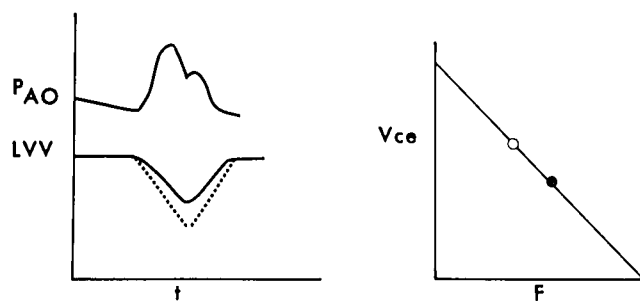

FIG. 5. Effect of reduced systemic vascular resistance on  $v_{ce}$ . *Left Panel:* Left ventricular volume decreases faster and farther when the shunt is open (interrupted line) than when it is closed (continuous line), and the corresponding aortic pressure traces are identical because higher flow occurs through lower resistance when the shunt is open. *Right Panel:*  $v_{ce}$  (ordinate) varies inversely with load (F, abscissae) for a given contractile state. Because F is proportional to the volume-pressure product, it is less throughout ejection when the shunt is open (○) because ventricular volume is less at the same pressure than when the shunt is closed (●). Accordingly,  $v_{ce}$  increases at the same contractile state when the shunt is open.

ard Goldberg, John Rabson, and Frederic Santman for their technical assistance and stimulating discussions; and Dr. J. B. Sutherland for his expert advice concerning nuclear cardiology techniques.

### References

1. Chatterjee K, Parmley WW: Vasodilator treatment for acute and chronic heart failure. *Br Heart J* 39:706-720, 1977
2. Franciosa JA, Cohn JN: Hemodynamic responsiveness of short and long-acting vasodilators in left ventricular failure. *Am J Med* 65:126-133, 1978
3. Brodie BR, Grossman W, Mann T, et al: Effects of sodium nitroprusside on left ventricular diastolic pressure-volume relations. *J Clin Invest* 59: 59-68, 1977
4. Sagawa K: The ventricular pressure-volume diagram revisited. *Circ Res* 43:677-687, 1978
5. Suga H, Kitabatake A, Sagawa K: End-systolic pressure determines stroke volume from fixed end-diastolic volume in the isolated canine left ventricle under a constant contractile state. *Circ Res* 44:238-249, 1979
6. Grossman W, Braunwald F, Mann T, et al: Contractile state of the left ventricle in man as evaluated from end-systolic pressure-volume relations. *Circulation* 56:845-852, 1977
7. Guyton AC, Sagawa K: Compensations of cardiac output and other circulatory functions in areflex dogs with large a-v fistulas. *Am J Physiol* 200:1157-1163, 1961
8. Dunlop D, Shanks RG: Selective blockade of adrenoceptive beta receptors in the heart. *Br J Pharmacol Chemotherp* 32:201-218, 1968
9. Dodge HT, Sandler H, Baxley WA, et al: Usefulness and limitations of radiographic methods for determining left ventricular volume. *Am J Cardiol* 18: 10-24, 1966
10. Noble MIM: The contribution of blood momentum to left ventricular ejection in the dog. *Circ Res* 23:663-670, 1968
11. Crozatier B, Caillet D, Thuillez C, et al: Preload changes modify systolic pressure-diameter relations in the conscious dog. *Am J Physiol* 240:H354-H360, 1981
12. Rogers WJ, Smith, LR, Hood WP, et al: Effect of filming and inter-observer variability on angiographic bi-plane left ventricular volume determination. *Circulation* 59:96-104, 1979
13. Berman DS, Salel AF, DeNarbo GL, et al: Clinical assessment of left ventricular regional contraction patterns and ejection fraction by high-resolution gated scintigraphy. *Diagn Nuc Med* 16: 865-873, 1975
14. Mullins CB, Mason DT, Ashburn WL, et al: Determination of ventricular volume by radioisotope-angiography. *Am J Cardiol* 24:72-78, 1969
15. Suga H, Sagawa K: Instantaneous pressure-volume relationships and their ratio in the excised, supported canine left ventricle. *Circ Res* 35: 117-125, 1974
16. Weber KT, Janicki JS, Reeves RC, et al: Factors influencing left ventricular shortening in isolated canine heart. *Am J Physiol* 239:419-426, 1976
17. Weber KT, Janicki JS: Left ventricular force-length relations of isovolemic and ejection contractions. *Am J Physiol* 231:337-343, 1976
18. Weber KT, Janicki JS: Instantaneous force-velocity-length relations in isolated dog heart. *Am J Physiol* 232:H241H249, 1977
19. Walley K, Prewitt RM, Wood LDH: Reduced end-systolic volume (ESV) during reduced resistive afterload is not due to increased contractility. *Fed Proc* 39: 814, 1980
20. Spencer MP, Denison AS Jr: Pulsatile blood flow in the vascular system, *Handbook of Physiology, Section 2: Circulation*. Edited by Hamilton WF. Baltimore, Waverley Press, Inc., 1964, pp 839-864
21. Elzinga G, Westerhof N: Pressure and flow generated by the left ventricle against different impedances. *Circ Res* 32: 178-186, 1973
22. Imperial ES, Levey MN: Outflow resistance as an independent determinant of cardiac performance. *Circ Res* 9:1148-1155, 1961
23. Milnor WR: Arterial impedance as ventricular afterload. *Circ Res* 36:565-570, 1975
24. Paulus WJ, Claes VA, Brutsaert DL: Physiological loading of isolated mammalian cardiac muscle. *Circ Res* 39:52-53, 1976
25. Paulus WJ, Claes VA, Brutsaert DL: Physiological loading of isolated feline cardiac muscle. *Circ Res* 44:491-497, 1979
26. Hill AV: The mechanical efficiency of frog's muscle. *Proc R Soc Lond* 127:434-451, 1939