

LABORATORY REPORT

Anesthesiology
71:150-153, 1989

Vaporizer for Volatile Anesthetics during High-frequency Jet Ventilation

Manoochehr Mazloomdoost, M.D.,* Miroslav Klain, M.D., Ph.D.,† Edwin M. Nemoto, Ph.D.,‡ Marina R. Lin, M.S.,‡ Wilfred Lee-Foon§

At present, the potent inhalation anesthetics cannot be used during high-frequency jet ventilation (HFJV) because a suitable vaporizer is not available. A vaporizer for enflurane during HFJV was designed, built, and tested, based on the principle of airblast atomization in which liquid enflurane is delivered to the vaporizer by an infusion pump. Eight dogs were kept anesthetized with enflurane for 2 h using this device. Vital signs and arterial blood gases were within normal limits during anesthesia. The concentration of vaporized enflurane, measured by mass spectrometry, could be reliably and accurately controlled within the clinical range at any minute volume by adjusting the infusion rate. Measurements of blood enflurane indicated that enflurane uptake could be adequately achieved. (Key words: Anesthetics, volatile: enflurane. Equipment: vaporizers. Ventilation: high-frequency jet.)

HIGH-FREQUENCY jet ventilation (HFJV) is an accepted means of ventilation for patients undergoing fiberoptic bronchoscopy,¹ other endoscopies,² and surgery of bronchopleural fistula.³ In addition, it has been used during cardiopulmonary resuscitation⁴ to prevent aspiration,* and in the treatment of acute fulminant pulmonary edema.⁵ In the operating room, however, HFJV cannot at present be used with volatile anesthetics. First, the desirable bronchodilating effects of volatile anesthetics cannot be utilized.⁶ Second, awareness during anesthesia occurs more frequently with balanced anesthesia than with other techniques.⁷ To be able to use inhalation volatile anesthetics during HFJV, new vaporizing devices are needed that will operate in the presence of high pressures (20-50 psi). We designed such a device and tested its reliability in bench tests and in dogs. In bench tests we asked the following questions: Can the device deliver a predictable concentration of anesthetic within the clinical range? How accurately can anesthetic concentration be con-

trolled? In dogs we determined whether the vaporizer could provide clinical anesthesia with enflurane during HFJV.

Materials and Methods

VAPORIZER DESIGN

The vaporizer is designed on the principle of airblast atomization, in which a gas is passed at high velocity over a thin layer of fluid and the fluid is disintegrated into small droplets, which are dispersed and instantly evaporate because of the substantial increase in surface area.† Water droplets 10 μm in diameter evaporate within 60 ms at 20° C.⁸ Such physical properties of enflurane as its low boiling point and low latent heat of vaporization⁹ suggest that in airblast-atomization it should evaporate more rapidly than water.

In tube A of the vaporizer (fig. 1) the air jet of the HFJV passes through a 14-G needle (C) over the tip of the 20-G needle (E) through which the liquid anesthetic is infused. The tips of these two needles can be seen through a glass portal. Tightening pin (B) helps to stabilize the needle (C), and pin (D) stabilizes needle (E). The endotracheal tube is connected to (A) opposite the needle (C). Expired gases exit *via* tube F to a scavenging system. Another tube (G) opens into tube A at 90° opposite the glass portal to allow use of the vaporizer in a circle system in which tube G is connected to inspiratory and (F) is connected to expiratory limb. Tube G was occluded and tube F was connected to scavenging system during these experiments. A photograph of the device is shown in figure 2.

BENCH TESTS

To evaluate the vaporizer, the system shown in figure 3 was used with a 3-l bag attached to an endotracheal tube. Ventilator settings were as follows: rate, 150/min; inspiratory time, 30%; and 100% O₂. Driving pressure was adjusted to control minute volume at 15, 20, and 25

* Associate Professor of Anesthesiology.

† Professor of Anesthesiology.

‡ Senior Research Associate in Anesthesiology.

§ Electronic Specialist.

Received from the Department of Anesthesiology and Critical Care Medicine, University of Pittsburgh School of Medicine, Pittsburgh, Pennsylvania. Accepted for publication March 1, 1989.

Address reprint requests to Dr. Mazloomdoost: Department of Anesthesiology, University of Kentucky, 800 Rose Street, Lexington, Kentucky 40536-0084.

* Keszler H, Klain M, Nordin U: High frequency jet ventilation prevents aspiration during cardiopulmonary resuscitation. *Disaster Medicine* 1:218-219, 1983.

† Dussourd JL, Lohman RP, Uram EM: Fluid mechanics of combustion. Joint Fluid Engineering and CSME Conference, Montreal Quebec, May 13-15, 1974. American Society of Mechanical Engineers. United Engineering Center, New York.

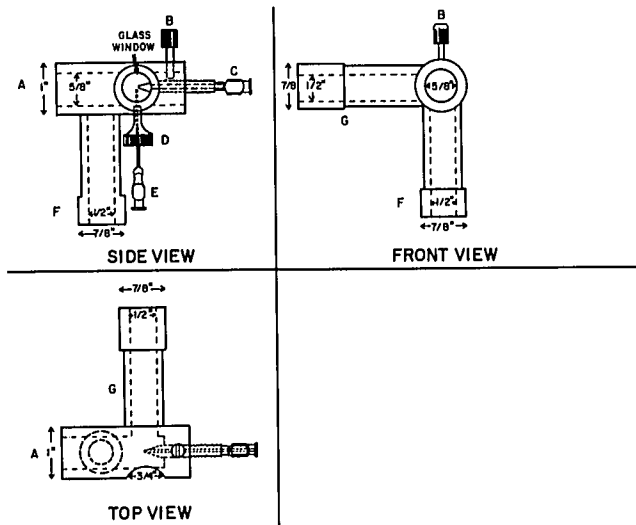

FIG. 1. Three views of vaporizer for delivery of volatile inhalation anesthetics during HFJV. The HFJV air jet passes through a 14-G needle (C) over the tip of the 20-G needle (E) through which the liquid anesthetic is infused. The tips of these two needles can be viewed through the glass window. The endotracheal tube is connected to A, and expired gases exit via tube F to a scavenging system. Tube G is connected to the inspiratory limb and tube F to the expiratory limb of a circle system.

l/min. An infusion pump (Sigma Co., St. Louis, Missouri) was used to infuse enflurane at rates of 0.5, 1, 1.5, 2.0, 2.5, and 3.0 ml/min at each minute volume. Delivered enflurane concentrations were measured by a mass spectrometer (Perkin-Elmer, Pomona, California) at the side-port of the endotracheal tube. Each setting of minute volume and flow rate was tested four times, and the enflurane concentration was measured each time.

To evaluate whether changing back pressure could effect vaporizer performance, additional measurements were made after different PEEP valves were inserted on the exhalation side to change the back pressure. Minute volume was kept constant, but back pressure was changed from atmospheric pressure to 5, 10, 15, 20, and 25 cmH₂O consecutively. The infusion pump was adjusted to starting concentration (at atmospheric pressure) of 1%, 2%, and 3% of enflurane. As back pressure was changed, enflurane concentration was continuously recorded.

STUDIES IN DOGS

After approval by the Animal Care Committee, eight dogs of either sex, weighing 18–22 kg, were anesthetized with 10 mg/kg iv thiopental and immobilized with 80 µg/kg of pancuronium bromide (Pavulon, Organon, Inc.). Endotracheal tubes were inserted and the dogs lungs were mechanically ventilated (Harvard Ventilator Model #607,

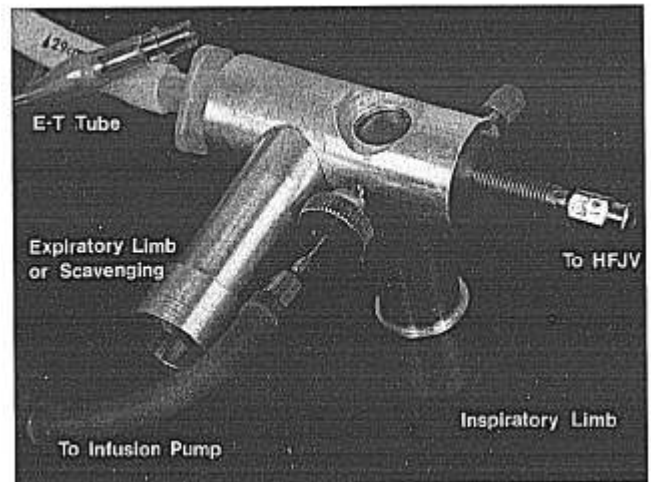

FIG. 2. Actual view of the vaporizer. It shows how it is connected to endotracheal tube, infusion pump, and high-frequency jet ventilator.

Harvard Apparatus, Inc.). Electrocardiogram (ECG) leads were attached, and pulmonary artery, femoral artery, and femoral venous catheters were inserted. Ventilation was then switched to HFJV (model VS600, Instrument Development Co., Pittsburgh, Pennsylvania). Fixed ventilator settings chosen were as follows: driving pressure, 20–50 psi as needed to provide adequate minute volume and CO₂ elimination; inspiratory time, 30%; rate 150 breaths/min; and FI_{O₂} = 1.00. Baseline measurements of mean arterial blood pressure (MAP), cardiac output, and arterial blood gases were made. The minute volume was measured, and liquid enflurane infusion into the vaporizer was begun with an infusion pump (Sigma Co., St. Louis, Missouri). The rate of infusion was adjusted to the minute volume to obtain an inspired enflurane concentration of 2.2% as measured by mass spectrometry. Then, minute volume and infusion rate were kept constant throughout 120 min. All monitored physiologic variables were recorded every 15 min after the start of enflurane infusion. Arterial and venous blood enflurane levels were measured at 5, 15, 30, 60, 90, and 120 min. Residual muscle relaxation was reversed with 1 mg neostigmine and 0.4 mg atropine at the end of the studies.

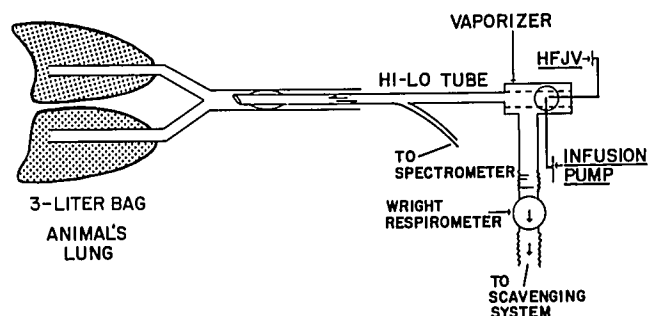

FIG. 3. System used to bench test anesthetic delivery by the vaporizer during HFJV.

‡ From Boehringer Laboratories, Wynnewood, PA 19096. PAT # 3908987.

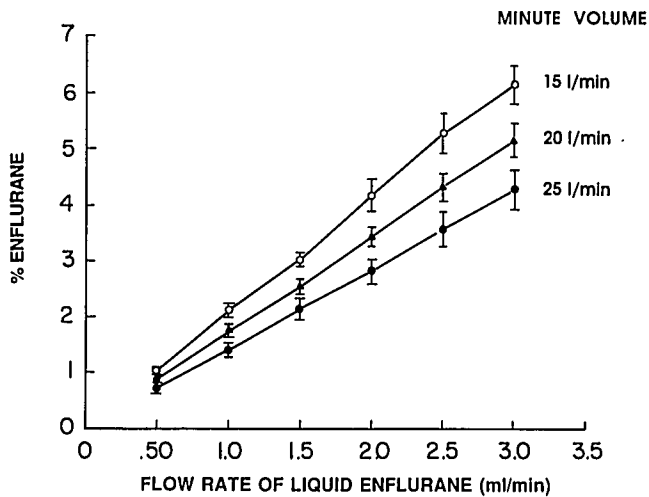

FIG. 4. Relationship between infusion rate of liquid enflurane, minute ventilation and percent inspired enflurane delivered using the vaporizer with HFJV. Values are mean \pm SEM; $n = 4$.

MEASUREMENT OF PLASMA ENFLURANE

Exactly 1.0 ml of whole blood was added to preweighed screw-top test tubes containing 1.0 ml toluene with chloroform as an internal standard.¹⁰ The tubes were capped immediately, vigorously agitated, and placed on a rocking shaker for 30 min. One microliter of the sample was injected into a model 3700 Varian gas-liquid chromatograph with a flame ionized detector and a 6-ft glass column packed with 3.0% SE-30. Injector/column/detector temperatures were set at 120/60/120° C and carrier N₂ gas flow rate at 30 ml/min. Peaks were integrated by a Shimadzu CRIA microprocessor, and enflurane concentrations calculated relative to the internal standard and standard calibration curves.

METHOD

Statistical analyses were done by one-way analysis of variance of repeated measures and the differences between means were tested for significance using the Student-Newman-Keuls test at a P value \leq 0.05.

Results

BENCH TESTS

The delivery of the anesthetic in terms of inspired concentration was linear at minute volume between 15 and 25 l/min (fig. 4). As expected, enflurane concentration increased with decreasing minute volume. As minute volume was reduced from 25 to 15 l/min, at an enflurane infusion rate of 3 ml/min vaporized enflurane concentration increased from 4.23% to 6.01%. When minute volume was reduced from 25 to 15 l/min, at an enflurane infusion rate of 1 ml/min enflurane concentration increased from 1.43% to 2.06%. No change in enflurane

concentration was observed with changes of back pressure between 0 and 25 cmH₂O.

STUDIES IN DOGS

Before administration of enflurane during HFJV, MAP was 123 ± 3 mmHg (mean \pm SEM) with a cardiac index (CI) of 5.2 ± 0.3 . Arterial blood gases indicated adequate ventilation with a PaO₂ of 490 ± 6 mmHg and PaCO₂ of 32 ± 1 mmHg 5 min after the administration of enflurane. After 5 min MAP decreased to 109 ± 3 mmHg and CI

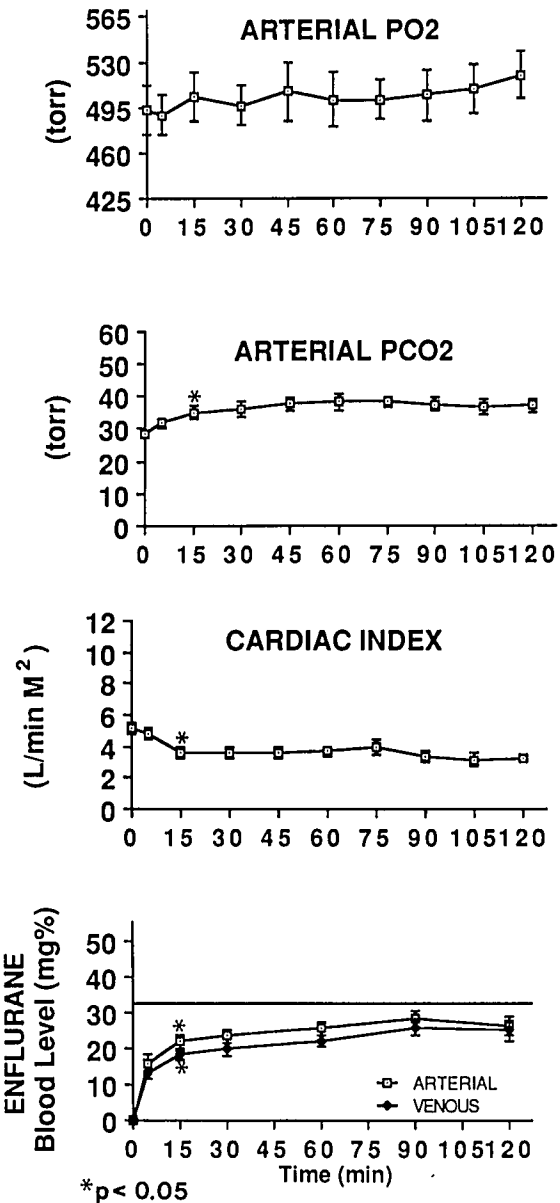

FIG. 5. Physiologic variables in eight dogs during enflurane anesthesia with HFJV. Values shown are mean \pm SEM. Mechanical ventilation was switched from the conventional ventilator to HFJV at 0 min at an inspired enflurane concentration of 2.2% as measured by mass spectrometry. Values shown are mean \pm SEM. Values changed little after 15 min.

to 3.6 ± 0.3 . After 15 min MAP decreased further to 89 ± 6 mmHg and then remained at about that level for up to 120 min; CI remained at 3.2 to 3.9 after 5 min. Arterial blood gases were relatively stable. Although P_{aCO_2} increased gradually in the first 15 min, it remained at about 36–38 mmHg thereafter (fig. 5). The decrease in CI in the first 15 min appears to be proportionate to the increase in arterial blood level of enflurane. Arterial blood enflurane increased to 21.9 mg/dl in the first 15 min, 23.5 mg/dl in the first 30 min and thereafter increased only slightly, to 28.2 mg/dl. All animals could stand within several minutes after enflurane was discontinued.

Discussion

The vaporizer we have designed can deliver enflurane at concentrations in the clinical useful range. The resulting concentration depends on minute volume but is not influenced by back pressure as shown in our bench tests. By adjusting the infusion rate, the desired concentration can be achieved. Inspired concentrations at minute volume other than 15, 20, and 25 l/min may be estimated (fig. 4), then confirmed by mass spectrometry. Arterial blood gases reflected adequate ventilation.

Although no controlled study has compared delivery of anesthetics during HFJV versus conventional ventilation, Torri *et al.*¹¹ studied the time course of enflurane uptake with conventional ventilation. Their observations were similar to what we observed with HFJV. In both studies enflurane uptake reached a near-plateau after about 30 min.

During HFJV measurements of end-tidal enflurane are meaningless because tidal volume is less than dead space. Therefore, we measured arterial blood concentrations of enflurane. The upper limit that arterial blood concentration of anesthetic at complete equilibration could reach at an alveolar concentration of 2.2% is 32.8 mg/dl. The calculated ratio of alveolar/arterial blood concentration for enflurane with time was 48.6% at 5 min, 67.8% at 15 min, and 71.6% at 30 min in our study. Torri *et al.*¹¹ reported comparable values of 50.0%, 61.8%, and 70.1% at these time intervals during conventional ventilation. Thus, the anesthetic uptake with this vaporizer during HFJV is similar to the anesthetic uptake during conventional ventilation.

Although the vaporizer we designed has an inspiratory limb (G in fig. 1), we used the vaporizer in a nonrebreathing system. The use of a semiclosed rebreathing circuit during HFJV with inhalation anesthesia might have complicated the study. Rebreathing could affect the inspired anesthetic concentration because both the volume and the concentration of anesthetic in the exhaled gas are subject to a variety of influences. The volume of the entrained portion may change if lung compliance changes

or if the animal attempts to breathe. Also, the concentration of anesthetic in the rebreathing circuit depends on the concentration in the exhaled air, which may vary if cardiac output changes. Variations in the absorption of the anesthetic by soda lime and rubber could also vary its concentration in the circuit. However, this vaporizer can be used in a circle system with continuous monitoring of anesthetic concentration. With this method considerably less anesthetic would be consumed.

If the ventilator is inadvertently turned off but the infusion pump is continued, liquid enflurane could be delivered into the vaporizer. Tube F is designed such that liquid anesthetic could flow into scavenging system, rather than toward the patient. Concentrations of more than 4–5% could also produce small droplets. Fortunately, these concentrations are not needed clinically. No condensation of enflurane was observed inside the endotracheal tube.

In conclusion, this device can be used to vaporize volatile inhalation anesthetics during HFJV. The inspired concentration of enflurane is easily controlled within the clinical range by changing the ratio of the infusion of liquid enflurane to minute volume. From our study in dogs, it is apparent that the addition of this vaporizer to HFJV does not disturb ventilation.

Enflurane was kindly supplied by Anaquest, Inc.

References

1. Smith RB, Lindholm CE, Klain M: Jet ventilation for fiberoptic bronchoscopy under general anaesthesia. *Acta Anaesthesiol Scand* 20:111–116, 1976
2. Scheck PA, Mallios C: Peroral endoscopies using intravenous anesthesia and high-frequency ventilation. *Crit Care Med* 12: 803–805, 1984
3. Benjaminsson E, Klain M: Intraoperative dual-mode independent lung ventilation of a patient with bronchopleural fistula. *Anesth Analg* 60:118–119, 1981
4. Klain M, Keszler H, Brader E: High frequency jet ventilation in CPR. *Crit Care Med* 9:421–422, 1981
5. Schuster DP, Snyder J, Klain M, Grenvik A: High frequency jet ventilation during the treatment of acute fulminant pulmonary edema. *Chest* 80:682–685, 1981
6. Hirshman CA, Bergman NA: Halothane and enflurane protect against bronchospasm in an asthma dog model. *Anesth Analg* 57:629, 1978
7. Harris TJB, Brice DD, Hetherington KK, Utting JE: Dreaming associated with anaesthesia: The influence of morphine premedication and two volatile adjuvants. *Br J Anaesth* 43:172–179, 1971
8. Scurr C, Feldman S: *Scientific Foundations of Anaesthesia*, 2nd edition. Chicago, Year Book 1974, p 490
9. Dripps RD, Eckenhoff JE, Vandam JF: *Introduction to anesthesia, The Principles of Safe Practice*, 6th edition. Philadelphia, WB Saunders, 1977, p 118
10. Wolfson B, Ciccarelli HE, Siker EJ: Gas chromatography using an internal standard for the estimation of ether and halothane levels in blood. *Br J Anaesth* 38:591–595, 1966
11. Torri G, Damia G, Fabiani L, Frova G: Uptake and elimination of enflurane in man. *Br J Anaesth* 44:789–793, 1972