

Anesthesiology
79:83-87, 1993
© 1993 American Society of Anesthesiologists, Inc.
J. B. Lippincott Company, Philadelphia

Positive End-expiratory Pressure Lowers the Risk of Laser-induced Polyvinylchloride Tracheal-tube Fires

Annette G. Pashayan, M.D.,* Carla SanGiovanni, M.E.,† Lawrence E. Davis, M.E.‡

Background: The possibility of ignition of polyvinylchloride (PVC) tracheal tubes by a CO₂ laser is of concern in patients undergoing CO₂ laser surgery of the airway. The authors analyzed the ignition of PVC tracheal tubes by a CO₂ laser beam to determine what variables were involved, and then designed a study to determine how they affect the incidence of such fires.

Methods: For the analysis, PVC tracheal tubes were enclosed in a clear plexiglass enclosure and a laser beam was focused on the tubes. The enclosure contained one of three different gas combinations. A high-speed camera photographed the tubes during the analysis and showed that tracheal tube perforation always preceded ignition in all three gas combinations. These results led to the hypothesis that intraluminal gauge pressure (IGP) may be an important variable, because it would affect the flow of O₂ across the perforation. This hypothesis was tested by aiming a CO₂ laser beam at PVC tracheal tubes and varying IGP in 0.25-cm H₂O increments, from 0.25 to 28 cm H₂O, while nitrogen or helium containing O₂ at 40, 50, or 60% flowed through the tubes. To simulate the clinical effect of IGP on PVC tracheal tube ignition, we used a mechanical lung model connected to an anesthesia breathing circuit with a standing bellows ventilator in which 60% He and 40% O₂ flowed through a PVC tracheal tube. Laser beam exposure was started at three different times during the respiratory cycle: at the start of inspiration, at the end of inspiration, or at the end of expiration. Also, for each condition, trials were made at baseline circuit pressure (2.5 cm H₂O) and at 5.0 cm H₂O by the addition of 2.5 cm H₂O positive end-expiratory pressure (PEEP) applied to the circuit.

Results: The incidence of tracheal tube ignition decreased as IGP increased. The IGP at which ignition did not occur

(which increased as O₂ concentration increased) did not differ between N₂ and He at 40% O₂, but was twice as high with N₂ as with He at O₂ of 50% and 60%. Fires never occurred when PEEP was added to the system and, when PEEP was not added, always started during the last 2 s of end expiration (when airway pressure is lowest), regardless of when the laser beam was activated.

Conclusions: It is recommended that, in addition to other safety practices, PEEP be added to the breathing circuit during CO₂ laser operations on the airway in which PVC tracheal tubes or laser-resistant tracheal tubes with PVC components are used. (Key words: Airway, operations. Carbon dioxide: laser. Complications: burns. Equipment: tubes, endotracheal. Intubation, tracheal. Surgery: laser. Ventilation: positive end-expiratory pressure.)

DESPITE the increased availability of laser-resistant tracheal tubes (LRTT) and fire risk-reducing protocols (such as using helium in anesthetic gas mixtures), fires continue to be a problem during operations on the airway when lasers are used.^{1,2} Although these fires can occur even when a tracheal tube is not present in the airway,³ they usually result from contact between the laser beam and the flammable components of a tracheal tube. Severe burns of the larynx and trachea may result from such fires and can lead to long-term disability or even death.^{1,2,4} We hypothesized that careful observation of tracheal tube ignition would lead to a better understanding of the sequence of events leading to and following fires. These observations led us to investigate the effect of intraluminal gauge pressure (IGP) on the incidence of tracheal-tube fires in the airway.

Materials and Methods

Ignition Analysis

To determine the sequence of events leading to a laser-induced fire, the process was filmed under different conditions with a high-speed camera (Wollensak Fastax WF 14, Livingston, NJ) capable of 2,000 frames/s. Standard polyvinylchloride (PVC) tubes (Sheridan, Argyle, NY) of 6.5 mm inner diameter (ID) were suspended within a rectangular, transparent plexiglass

* Associate Professor of Anesthesiology.

† Graduate Student in Mechanical Engineering; currently Performance Engineer at Westinghouse Electric Corp., Orlando, Florida.

‡ Graduate Student in Mechanical Engineering; currently Mechanical Engineer at Motorola Inc., Boynton Beach, Florida.

Received from the Departments of Anesthesiology and Neurosurgery, College of Medicine, and Department of Mechanical Engineering, College of Engineering, University of Florida, Gainesville, Florida. Accepted for publication March 1, 1993. Presented in part at the annual meeting of the American Society of Anesthesiologists, Las Vegas, Nevada, October 19-23, 1990, and San Francisco, California, October 26-30, 1991.

Address reprint requests to Dr. Pashayan: Editorial Office, Department of Anesthesiology, University of Florida College of Medicine, P.O. Box 100254, Gainesville, Florida 32610-0254.

enclosure (fig. 1). To control the composition of gas flowing through the tube, the tubes were attached to two gas connectors located on opposing walls of the enclosure. Two additional ports on the walls of the enclosure, which opened into the space surrounding the tube, were used to control the gas composition around the tube. The camera was positioned so that the tube lay horizontally across the lens field. The camera was operated manually, and film exposure was begun before the laser was started to give the film time to accelerate. The tubes were illuminated with an incandescent light to attain proper film exposure. A CO₂ laser (Sharplan 1040; Laser Industries, Tel Aviv, Israel) was placed so that its beam was perpendicular to the tube. The beam was aimed at a clear portion of the shaft of the tracheal tube.

Tubes were photographed under three test conditions of varying intraluminal and extraluminal concentrations of O₂ (table 1). In each case, gas flowed from two anesthesia semiclosed breathing circuits, one for gas flow through and one for gas flow around the tube, at 5 l/min. Before testing, O₂ concentrations were verified with a standard polarographic O₂ analyzer on the outflow ports of the circuits. The laser delivered a 25-W beam with a 1.0-mm diameter. This relatively high power density (3,185 W/cm²) was necessary to ignite the tube within the brief time of high-speed film exposure.

Analysis of Intraluminal Pressure

To evaluate the effect of IGP on ignition, gas was directed in a constant, unidirectional flow at 20 l/min

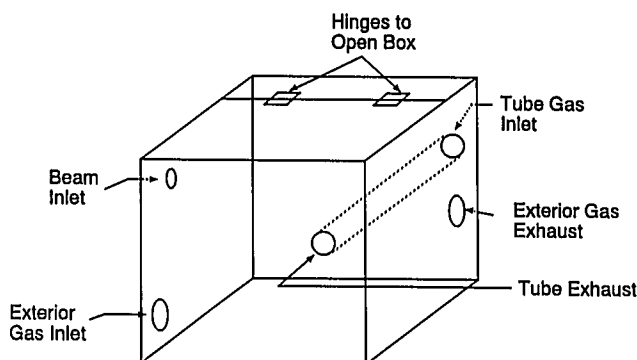

Fig. 1. Plexiglass enclosure used to film, at high speed, the sequence of events as a CO₂ laser beam ignites the polyvinylchloride tracheal tube. The tube was attached to gas connectors that, in turn, were attached to opposing walls of the enclosure. These gas connectors and others placed in the walls enabled the extraluminal and intraluminal gas composition to be controlled.

Table 1. Intraluminal and Extraluminal O₂ Concentrations during High-speed Photography of Tracheal Tube Fires Induced by a CO₂ Laser Beam

Intraluminal/Extraluminal O ₂ Condition	Intraluminal Concentration (%)		Extraluminal Concentration (%)	
	O ₂	N ₂	O ₂	N ₂
High/air	50	50	21	79
High/high	50	50	50	50
Air/high	21	79	50	50

through PVC tubing with 6.5-mm ID. By varying the length of the tubing downstream from the site of laser beam contact, IGP was varied in increments of 0.25 cm H₂O, from a low of 0.25 cm H₂O up to 28 cm H₂O. For example, to increase IGP by 0.25 cm H₂O, an additional 10 cm of tubing was added. Time before ignition was measured over the entire range of IGP with an intraluminal gas flow of six different gas combinations: nitrogen (N₂) or helium (He) in O₂, 40, 50, or 60%. At each gas combination and each IGP, the CO₂ laser beam at 10 W and a 0.8-mm spot size (power density = 1,990 W/cm²) was directed at the tube at a 90° angle (n = 8 tubes at each combination). If no fire occurred within 60 s, then "no fire" was recorded. The "nonignitability IGP" was considered to be that IGP above which no tubes out of eight ignited for each gas mixture. Laser output was verified with a watt meter before each day's tests. Gas flow rate was monitored with a precalibrated flow meter (Fischer and Porter, Warminster, PA), and O₂ concentration with a standard polarographic O₂ analyzer. To monitor IGP continuously, at low IGP (<2.5 cm H₂O), an incline manometer was used, and, at high IGP (>2.5 cm H₂O), a water manometer was used.

In our clinical model of IGP and tracheal-tube fire risk, the "Y" piece of the breathing circuit tubing was attached to the connector ends of 6.5-mm-ID PVC tracheal tubes, which, in turn, were attached at the patient ends to a simulated adult tracheal model. The tracheal model was attached to a test lung that consisted of a resistor (2 cm H₂O l/sec) and a bellows set at a compliance of 100 ml/cm H₂O. Carbon dioxide (4%) was infused into the test lung. A standing bellows ventilator (Ohio 7000; Ohmeda, Madison, WI) was set at a tidal volume of 550 ml, a rate of 10 breaths/min, an inspiratory-to-expiratory ratio of 1:2, and a fresh gas flow of 5 l/min. The values for resistance and compliance and ventilator settings were selected to model condi-

LASER-INDUCED TRACHEAL FIRES

tions in a normal adult. Gas flow, which consisted of 60% He and 40% O₂, was measured using a Fleisch pneumotachograph (Dyna Sciences, Blue Bell, PA) and airway pressure was measured with a standard pressure transducer; both were recorded on a multichannel recorder (Grass, Quincy, MA). The F_IO₂ was monitored continuously with a polarographic O₂ analyzer. For laser exposure, a CO₂ laser beam of 10 W and a 0.8-mm spot size (power density = 1,990 W/cm²) was begun at the start of inspiration, at the end of inspiration, or at the end of the expiratory pause. The beam was directed at the tracheal tube at a 90° angle until a fire occurred or 60 s passed. Trials were run (n = 60, ten at each set of conditions) under two conditions of positive end-expiratory pressure (PEEP): at a baseline circuit pressure of 2.5 cm H₂O and at 5.0 cm H₂O by addition of 2.5 cm H₂O pressure to the expiratory limb of the breathing circuit. The baseline pressure was the result of using a standing bellows ventilator in the respiratory circuit. The 5.0 cm H₂O level was achieved by applying a disposable threshold resistor PEEP valve (Vital Signs, Totowa, NJ).

Data Analysis

Data were analyzed using quadratic regression analysis. Alpha was set at 0.05 for statistical significance.

Results

Ignition Analysis

Tubes ignited under all three extra- and intraluminal O₂ conditions and perforation of the PVC tracheal tube wall always preceded the fire. All fires started at the site of perforation.

Analysis of the Effect of Intraluminal Pressure

The incidence of PVC tracheal tube ignition was inversely related to IGP at each O₂ concentration (fig. 2). With both He and N₂, the nonignitability IGP in-

creased as the concentration of O₂ increased (table 2, fig. 2). The nonignitability IGP was similar for both gases when O₂ was 40%, but was approximately twice as high with N₂ as He when O₂ was 50% and 60% (table 2). In the clinical model, because of the baseline pressure within the breathing circuit produced by a standing bellows ventilator, PEEP measured 2.5 cm H₂O higher than the amount applied to the breathing circuit. Fires only occurred when PEEP was at a baseline pressure of 2.5 cm H₂O and always started during the last 2 s of the expiratory pause, when pressure was lowest (table 3), regardless of when the laser beam was activated.

Discussion

A protective wrap reduces the likelihood that a tracheal tube will be ignited by a laser beam but does not eliminate this risk. In particular, the cuff of a tube cannot be wrapped and so remains vulnerable to ignition by the laser beam. Although laser-resistant tracheal tubes (LRTT) also reduce the likelihood of tracheal-tube fire, the clinician must keep in mind that most of these products contain flammable materials, such as PVC^{5,6}; therefore, the manufacturers' guidelines and limitations for the use of each LRTT must be followed to incur resistance to lasers. Specific guidelines, including the laser wavelength to which the LRTT is resistant and the limits of F_IO₂ and of laser output, should be clearly stated in the product insert and followed by the practitioner. The current study, however, indicates that other, previously unrecognized variables—such as the method of ventilation—may also be important to control to prevent an airway fire.

Ignition always followed, and never preceded, tube perforation, even in the presence of high extraluminal O₂. This explains why PVC still presents a substantial fire risk, although its O₂ index of flammability (defined as the minimum concentration of O₂ needed to support a candle-like flame) is greater than 0.21.⁷ Although the cuff of the tube may seal the trachea and prevent escape of anesthetic gases to the extraluminal tube surface and, thus, extraluminal gas has an F_IO₂ of 0.21, PVC is easily melted and perforated; thus, intraluminal gas with an increased F_IO₂ may reach the heated region of tube around the perforation and allow ignition. This information also refutes the common misconception that leaks of anesthetic gases from around an incompetent tracheal tube cuff are a primary cause of tracheal-tube fires. Both the composition and flow of gases across the tube perforation caused by the laser have more influ-

Table 2. Nonignitability Intraluminal Gauge Pressure with He or N₂ in O₂

O ₂ (%)	Nonignitability Gauge Pressure (cmH ₂ O)	
	He	N ₂
40	3.8	3.0
50	8.1	15.2
60	15.2	27.9

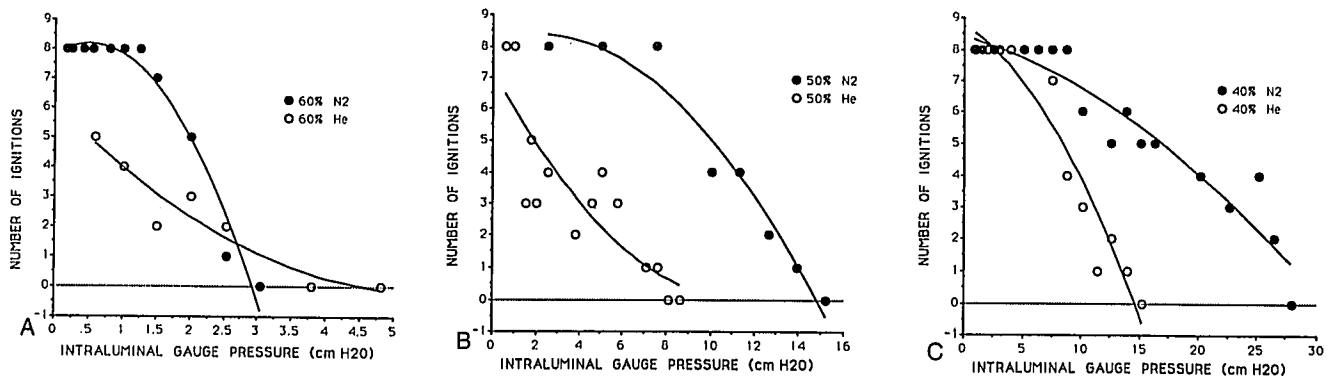

Fig. 2. Number of times out of eight trials that a CO₂ laser beam ignited polyvinylchloride tubes as helium or nitrogen in O₂ flowed through the tube at different intraluminal gauge pressures. (A) First gas mixture is 60% N₂/40% O₂; equation used is $y = 7.79 + 1.47x - 1.41x^2$; $R^2 = 0.96$; and $P = 0.0001$. Second gas mixture is 60% He/40% O₂; equation used is $y = 6.07 - 2.28x + 0.21x^2$; $R^2 = 0.91$; and $P = 0.009$. (B) First gas mixture is 50% N₂/50% O₂; equation used is $y = 8.13 + 0.214x - 0.05x^2$; $R^2 = 0.96$; and $P = 0.0004$. Second gas mixture is 50% He/50% O₂; equation used is $y = 7.22 - 1.26x + 0.06x^2$; $R^2 = 0.72$; and $P = 0.0009$. (C) First gas mixture is 40% N₂/60% O₂; equation used is $y = 8.42 - 0.113x - 0.01x^2$; $R^2 = 0.91$; and $P = 0.0001$. Second gas mixture is 40% He/60% O₂; equation used is $y = 8.77 - 0.227x - 0.026x^2$; $R^2 = 0.93$; and $P = 0.0001$.

ence on ignition than the intra- or extraluminal FI_{O_2} per se. Previous studies of FI_{O_2} and tracheal tube ignition did not include gas flow across the perforation as an independent variable of ignitability, but the current study examined flow across the perforation as it relates to IGP. As IGP increases, the pressure differential between the intra- and extraluminal spaces increases and, thus, the flow rate across the perforation increases. This relationship is defined as follows:

$$Q = C\pi r^2 \sqrt{\frac{2\Delta P}{\rho}}, \quad (1)$$

where Q = the volumetric flow rate; C = a discharge coefficient; r = the radius of the perforation; p = the fluid density; and ΔP = the difference in pressure between the intraluminal and extraluminal spaces.⁸ Therefore, although we did not actually measure flow of gas across the perforation, flow can be expected to

vary directly with the square root of the pressure, and we did measure intraluminal pressure.

When a constant, unidirectional flow of gases with an FI_{O_2} of 0.4 produced an IGP of 0.5 cm H₂O, five of eight tubes ignited with He, and all eight tubes ignited with N₂ (fig. 2A). The incidence of ignition at low IGP was probably caused by the low flow of gases across the perforation, which provided a constant supply of O₂ to the heated region of the tube surrounding the perforation. As IGP increased further, however, the incidence of ignition decreased. This was because, as IGP increased, ΔP and flow velocity also increased, so that, even with increased O₂ supply to the heated region, the tube was cooled as flow convectively carried heat away from the perforation. Another effect of high flow across the perforation is that, if ignition did occur, the resulting flame is more likely to be extinguished by the blowing effect of the flow. Cooling and blowing were more pronounced with He than with N₂, as reflected in a lower incidence of ignition with He. This would be expected, because He has a higher thermal diffusivity (defined as the quantity of heat passing through 1 cm² of cross-sectional area per unit of time) of 1.621 cm² · s⁻¹, compared with N₂ at 0.199 cm² · s⁻¹. Helium's high thermal diffusivity would improve convective cooling, and its lower density would augment flow (equation 1) across the perforation. Therefore, with low IGP (greater than 0 but less than 5 cm H₂O), the risk of fire is greater than at higher IGP. That IGP influences fire propagation affecting flow has been substantiated by earlier studies that showed that flames did not propagate above a certain flow rate, which was

Table 3. Incidence of Tracheal Tube Fires Caused by CO₂ Laser with 60% He and 40% O₂ and Different Levels of Positive End-expiratory Pressure (PEEP)

Initiation of Laser Exposure	Incidence of Fires at Different Levels of PEEP* (n)	
	2.5 cmH ₂ O (n = 10)	5.0 cmH ₂ O (n = 10)
Start of inspiration	6	0
End of inspiration	5	0
End of expiration	5	0

* Measurement of PEEP showed it was always 2.5 cmH₂O higher than the amount applied.

LASER-INDUCED TRACHEAL FIRES

called the "blow-out" limit and was lower with He/O₂ than with N₂/O₂.⁹

Because, during the course of the ventilatory cycle, IGP varies and can be modified clinically by PEEP, we evaluated whether a PEEP-induced increase in IGP affects the incidence of tracheal-tube fires. In this clinical model of IGP and ventilatory cycle, in which circuit pressure remained positive throughout the respiratory cycle, no matter when during the cycle the laser beam was initiated, the tube always ignited during end-expiration when airway pressure was lowest. This confirms the hypothesis that risk is greatest at a low IGP because enough O₂ to sustain fire is delivered to the heated region surrounding the perforation, but at a flow rate too low to cool the tube or blow out the flame. When measured end-expiratory pressure was kept at 5 cm H₂O by applying 2.5 cm H₂O PEEP, no fire occurred with 40% O₂ in He and 4% CO₂, presumably because ΔP was high enough for flow to cool the heated region of the tube, blow out the flame, or both. This level of PEEP corresponds nicely with the data showing that no tubes tested in 40% O₂ and 60% He ignited at an IGP of 4 cm H₂O (fig. 2A).

Our results support the use of at least 5 cm H₂O PEEP with at least 60% He in the gas mixture during airway CO₂ laser operations in which PVC tracheal tubes or LRTT with PVC components are used. If gas mixtures using a higher concentration of O₂ and/or N₂ are used, higher levels of PEEP may be necessary to afford the same level of protection. Other safety measures, such as applying the lowest clinically acceptable laser power setting and shielding the PVC from the laser beam with a protective wrap to decrease the risk of tube perforation, should also be used. Because red rubber and silicone have different O₂ indices of flammability⁷ and

different resistances to perforation by lasers,¹⁰ our findings on the importance of IGP or PEEP in preventing tracheal-tube fires may not be applicable for tubes containing these materials. The effects of IGP and PEEP on these other materials merit study.

The authors wish to thank Drs. J.S. Gravenstein, V.P. Roan, and R.A. Gater for their guidance in the development of this project; and Dr. Michael Banner for assistance with statistical analysis.

References

1. Bingham HG, Gallagher TJ, Singleton GT, Gravenstein JS, Pashayan AG, Bjoraker DG: Carbon dioxide laser burn of laryngotracheobronchial mucosa. *J Burn Care Rehabil* 11:64-66, 1990
2. ECRI: Clinical perspective: The devastation of patient fires. *Health Devices* 21:3, 1992
3. Wegrzynowicz ES, Jensen NF, Pearson KS, Wachtel RE, Scamman FL: Airway fire during jet ventilation for laser excision of vocal cord papillomata. *ANESTHESIOLOGY* 76:468-469, 1992
4. Fried MP: A survey of the complications of laser laryngoscopy. *Arch Otolaryngol Head Neck Surg* 110:31-34, 1984
5. ECRI: Laser-resistant endotracheal tubes and wraps. *Health Devices* 19:109-139, 1990
6. ECRI: Evaluation: laser-resistant tracheal tubes. *Health Devices* 21:4-13, 1992
7. Wolf GL, Simpson JI: Flammability of endotracheal tubes in oxygen and nitrous oxide enriched atmosphere. *ANESTHESIOLOGY* 67: 236-239, 1987
8. White FM: *Fluid Mechanics*, 2nd edition. New York, McGraw-Hill, 1986, p 362
9. Sidebotham GW, Wolf GL, Stern J, Aftel R: Endotracheal tube fires: A flame spread phenomenon, Flammability and Sensitivity of Materials in Oxygen-Enriched Atmospheres, vol. 5, ASTM STP 1111. Edited by Stoltzfus JM, McIlroy K. Philadelphia, American Society for Testing and Materials, 1991, pp 168-178
10. Ossoff RH, Duncavage JA, Eisenman TS, Karlan MS: Comparison of tracheal damage from laser-ignited endotracheal tube fires. *Ann Otol Rhinol Laryngol* 92:333-336, 1983