

Long-term Effectiveness and Treatment Timing for Bionator Therapy

Kurt Faltin Jr, DDS, PhD;^a Rolf M. Faltin, DDS, MSc, PhD;^b Tiziano Baccetti, DDS, PhD;^c
Lorenzo Franchi, DDS, PhD;^c Bruno Ghiozzi, DDS;^d James A. McNamara Jr, DDS, PhD^e

Abstract: The aim of the present investigation was to provide information about the long-term effects and optimal timing for class-II treatment with the Bionator appliance. Lateral cephalograms of 23 class-II patients treated with the Bionator were analyzed at three time periods: T1, start of treatment; T2, end of Bionator therapy; and T3, long-term observation (after completion of growth). T3 includes a phase with fixed appliances. The treated sample was divided into two groups according to their skeletal maturity as evaluated by the cervical vertebral maturation (CVM) method. The early-treated group (13 subjects) initiated treatment before the peak in mandibular growth, which occurred after completion of Bionator therapy. The late-treated group (10 subjects) received Bionator treatment during the peak. The T1–T2, T2–T3, and T1–T3 changes in the treated groups were compared with changes in control groups of untreated class-II subjects by nonparametric statistics ($P < .05$). The findings of the present study on Bionator therapy followed by fixed appliances indicate that this treatment protocol is more effective and stable when it is performed during the pubertal growth spurt. Optimal timing to start treatment with the Bionator is when a concavity appears at the lower borders of the second and the third cervical vertebrae (CVMS II). In the long term, the amount of significant supplementary elongation of the mandible in subjects treated during the pubertal peak is 5.1 mm more than in the controls, and it is associated with a backward direction of condylar growth. Significant increments in mandibular ramus height also were recorded. (*Angle Orthod* 2003;73:221–230.)

Key Words: Class-II malocclusion; Functional jaw orthopedics; Cephalometrics; Cervical vertebral maturation

INTRODUCTION

The Balters' Bionator^{1,2} is one of the most commonly used appliances for functional treatment of class-II, division

I malocclusions associated with mandibular retrusion. The popularity of this appliance is due in part to a number of favorable characteristics that include the relative ease in the construction and clinical handling of the appliance and the high level of comfort for the patient, who usually shows positive acceptance and compliance. The generic term Bionator, as a matter of fact, describes a "family" of tooth-borne appliances that produce a forward positioning of the mandible in association with variable effects in the vertical plane, ie, open, close, or maintain the bite.³

^a Chair, Department of Orthodontics, School of Dentistry, University Paulista, São Paulo, Brazil; Invited Professor, Department of Facial Orthopedics, University of Ulm, Germany.

^b Associate Professor, Department of Orthodontics, School of Dentistry, University Paulista, São Paulo, Brazil.

^c Research Associate, Department of Orthodontics, The University of Florence, Florence, Italy; Thomas M Graber Visiting Scholar, Department of Orthodontics and Pediatric Dentistry, School of Dentistry, The University of Michigan, Ann Arbor, Mich.

^d PhD program in Pediatrics and Preventive Orthodontics, Department of Orthodontics, The University of Florence, Florence, Italy.

^e Thomas M and Doris Graber Endowed Professor of Dentistry, Department of Orthodontics and Pediatric Dentistry, School of Dentistry; Professor of Cell and Developmental Biology, School of Medicine; and Research Scientist, Center for Human Growth and Development, The University of Michigan, Ann Arbor, Mich; Private practice, Ann Arbor, Mich.

Corresponding author: Lorenzo Franchi, DDS, PhD, Università degli Studi di Firenze, Via del Ponte di Mezzo, 46-48, 50127, Firenze, Italy (e-mail: condax@tin.it).

After its introduction in 1964, the Bionator has been the object of several investigations aimed to identify both the dentoalveolar and skeletal effects of this appliance. Most studies dealt with short-term outcomes of Bionator therapy by using various types of control groups (untreated class-I or class-II subjects).⁴⁻⁸

Dentoalveolar changes consist of maxillary incisor retraction and uprighting, associated with proclination of the lower incisors (when capping of these teeth is not used). An increase in mandibular molar eruption caused by adjustments in the eruption facets of the appliance has been documented as well. Although no skeletal modification has been found for the maxilla, a favorable increase in total

mandibular length has been described consistently in patients treated with the Bionator. The skeletal changes are associated with significant effects on the soft tissues, mainly consisting of changes in the vertical dimensions of the face and position of the lips.^{9,10}

Recently, the issue of optimal treatment timing for functional jaw orthopedics has gained the attention of both researchers and clinicians. Cephalometric studies have shown that the therapeutic effectiveness of the most functional appliances¹¹⁻¹⁷ is greatest when these appliances are used during the ascending portion of the individual pubertal growth spurt. Typically, patients treated during the peak period demonstrate significant skeletal effects induced by the appliance, whereas patients treated in the prepeak period have the significant effects confined to the dentoalveolar level. The Bionator is no exception to these findings, as documented in the studies by Janson.^{4,5} In her short-term investigation, Janson described an insignificant slight increase in mandibular size when the Bionator was used during prepubertal developmental stages, whereas the mandibular changes became significant over untreated controls when the peak was included in the treatment period.

To our knowledge, the only long-term study on the craniofacial changes induced by the Bionator is by Rudzki-Janson and Noachtar,¹⁸ who evaluated a group of patients treated with the Bionator five years after the completion of retention. These patients showed an increase in the size of the mandible and a decrease in both the distal skeletal jaw relationship and the gonial angle. However, the lack of a control group of untreated subjects and the use of treatment outcome as criteria for case selection are limiting factors for an adequate appraisal of the effectiveness of Bionator therapy in the long term. Furthermore, no assessment of ideal treatment timing for this type of treatment was attempted in the study.

The aim of the present investigation is to provide information about the long-term effects of class-II malocclusion treatment with the Bionator and, concurrently, to analyze differences in the dentoskeletal response of patients treated before or during the peak in mandibular growth. The strengths of the study are the use of a group of untreated class-II subjects and the appraisal of stages in individual skeletal maturity by the cervical vertebral maturation (CVM) method.

SUBJECTS AND METHODS

The cephalometric records of 30 class-II malocclusion patients consecutively treated with the Bionator were collected from a single orthodontic practice where this type of therapy was used. The treatment protocol consisted of class-II correction by a Bionator constructed without coverage of the lower incisors, followed by approximately one year of fixed appliance therapy to refine occlusion. After

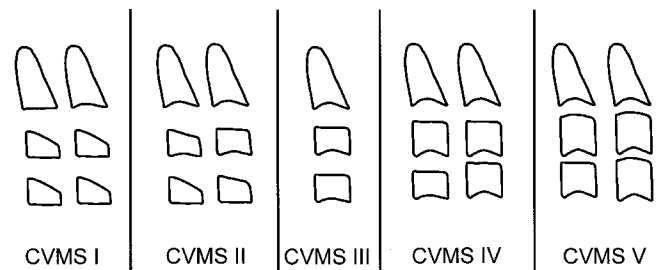

FIGURE 1. The new CVM method.

the comprehensive phase, each patient was given a fixed lower incisor retainer.

Seven patients were eliminated from the study because of the pretreatment absence of a full class-II molar relationship or poor film quality. The remaining 23 sets of cephalograms were analyzed. Final successful completion of therapy was not a criterion for case selection. Lateral cephalograms were obtained at three time periods: T1, at the start of treatment; T2, at the end of Bionator therapy; and T3, at long-term observation after completion of growth. Therefore, the effects of active treatment with the Bionator were assessed during the T1-T2 interval, whereas the analysis of T2-T3 interval provided information about the posttreatment changes that included a phase of treatment with fixed appliances to refine the occlusion. The T1-T3 interval was used to describe the overall treatment and posttreatment dentoskeletal modifications.

The treated sample was divided into two groups according to skeletal maturity at the start of treatment as evaluated by a recently implemented version of the CVM method.^{19,20} This version of the CVM method includes five maturational stages (CVMS I through CVMS V, instead of Cvs 1 through Cvs 6 in the former CVM method;²¹ Figure 1). The peak in mandibular growth occurs between CVMS II and CVMS III; the peak has not been reached without the attainment of CVMS II. CVMS V is recorded at least two years after the peak. The advantages of the new version of the CVM method are that mandibular skeletal maturity can be appraised on a single cephalogram and that it involves the analysis of only the second, third, and fourth cervical vertebrae, which usually are visible even when a protective radiation collar is worn.

The early-treated group (ETG; Table 1) consisted of 13 subjects (seven females and six males) presenting with CVMS I in cervical vertebrae maturation at T1. The stages in cervical vertebrae maturation at T2 were either CVMS I or CVMS II. Therefore, the peak in growth velocity was not included in the period of treatment with the Bionator for any of the subjects in the early group. The stages in cervical vertebrae maturation at T3 were either CVMS IV or CVMS V. The late-treated group (LTG; Table 1) included 10 subjects (six females and four males) presenting with CVMS II in cervical vertebrae maturation at T1. The stages in cervical vertebrae maturation at T2 were either CVMS

TABLE 1. Descriptive Statistics for Age and Observation Periods

	Mean Age			Mean Observation Period		
	T1	T2	T3	T1–T2	T2–T3	T1–T3
Early-treated group (n = 13)	9 y 8 mo ± 1 y 3 mo	11 y 6 mo ± 1 y 3 mo	17 y 5 mo ± 2 y	1 y 10 mo ± 7 mo	5 y 10 mo ± 2 y 2 mo	7 y 8 mo ± 2 y 5 mo
Early control group (n = 11)	9 y 5 mo ± 1 y 3 mo	11 y 6 mo ± 1 y 4 mo	16 y 4 mo ± 1 y 9 mo	2 y 1 mo ± 7 mo	4 y 10 mo ± 1 y 10 mo	6 y 10 mo ± 1 y 6 mo
Late-treated group (n = 10)	10 y 9 mo ± 1 y 8 mo	13 y 2 mo ± 2 y 3 mo	19 y 2 mo ± 2 y 2 mo	2 y 4 mo ± 1 y 6 mo	6 y 0 mo ± 10 mo	8 y 4 mo ± 1 y 8 mo
Late control group (n = 10)	11 y 2 mo ± 1 y 6 mo	12 y 11 mo ± 1 y 9 mo	17 y 2 mo ± 1 y 1 mo	1 y 9 mo ± 8 mo	4 y 3 mo ± 2 y 3 mo	6 y 0 mo ± 1 y 10 mo

III or CVMS IV. Therefore, the peak in growth velocity was included in the period of treatment with the Bionator for all the subjects in the late group. The stage in cervical vertebrae maturation at T3 was CVMS V.

The treated sample was compared with a sample of 21 subjects with untreated class-II malocclusions (control sample) selected from the University of Michigan Elementary and Secondary School Growth Study.²² The control sample also was divided into two groups according to the stage in CVM.

The early control group (ECG; Table 1) included 11 subjects (five females and six males), whereas the late control group (LCG; Table 1) consisted of 10 subjects (five females and five males). The control groups matched the corresponding treated groups to the stage in CVM at each observation period (T1, T2, and T3). The relatively shorter T2–T3 interval of observation in the LCG when compared with LTG did not affect the interpretation of the data because all the subjects in both LCG and LTG had completed the active phase of skeletal growth at T3 (CVMS V).

Cephalometric analysis

Lateral cephalograms of both treated groups and both control groups at T1, T2, and T3 were standardized to the magnification factor and analyzed by a digitizing tablet (Numonics, Lansdale, Pennsylvania, PA) and digitizing software (Viewbox, ver. 2.6).²³

A cephalometric analysis derived from both Johnston's²⁴ and Pancherz's²⁵ original analyses and comprising a modified reference system for the superimposition procedure was applied. The definitions for the landmarks used in the analysis have been provided previously.²⁶

The occlusal line (OL) and the occlusal line perpendicular (OLp) from the cephalogram at T1 were used as a reference grid. The grid was transferred from the initial tracing to subsequent tracings at T2 and T3 by superimposing the tracings on the T-FMN line, with T point as the registration point. All linear measurements were performed parallel to OL and perpendicular to OLp. The following variables were measured (Figure 2).

- is/OLp minus ii/OLp—overjet;
- ms/OLp minus mi/OLp—molar relation (a positive value

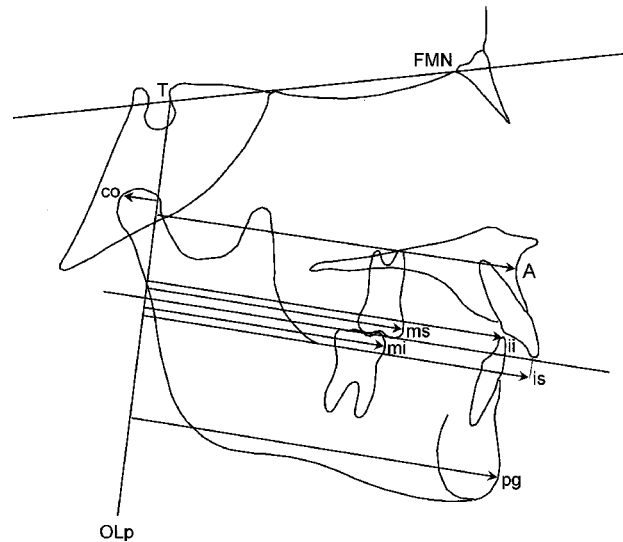
**FIGURE 2.** Cephalometric analysis.

indicates a distal relation; a negative value indicates a mesial relation);

- A point/OLp—sagittal position of the maxillary base;
- pg/OLp—sagittal position of the mandibular base;
- co/OLp—sagittal position of the condylar head;
- pg/OLp + co/OLp—composite mandibular length;
- is/OLp minus A point/OLp—sagittal position of the maxillary central incisor within the maxilla;
- ii/OLp minus pg/OLp—sagittal position of the mandibular central incisor within the mandible;
- ms/OLp minus A point/OLp—sagittal position of the maxillary permanent first molar within the maxilla;
- mi/OLp minus pg/OLp—sagittal position of the mandibular permanent first molar within the mandible.

Additional measurements for cranial base angulation, mandibular dimensions, and skeletal vertical relationships were obtained on all cephalograms at T1, T2, and T3, independently from the superimposition reference system (Figure 3).

- linear measurements—co-pg, co-go, go-pg;
- angular measurements—FMN-T-ba, FMN-T-ar, cl-ml, ar-go-me, nl/T-FMN line, ml/T-FMN line, nl-ml.

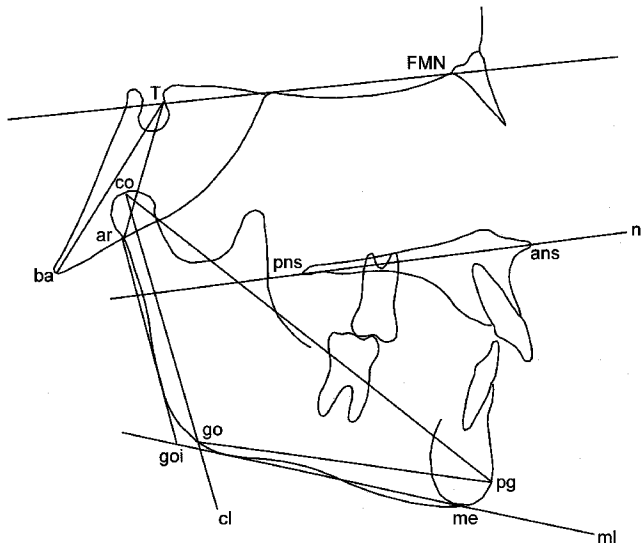

FIGURE 3. Additional cephalometric measures.

The method error and the coefficient of reliability for the cephalometric measurements have been described previously.²⁶

Statistical analysis

The starting forms of ETG and LTG were compared with those in ECG and LCG, respectively. Craniofacial modifications in the treated groups were compared with the growth modifications occurring in the corresponding control groups. In particular, T1–T2 changes were analyzed to describe the effects of active therapy with the Bionator. T2–T3 changes indicated posttreatment modifications including a phase with fixed appliances. T1–T3 changes provided information about the long-term overall effects of both treatment and posttreatment intervals. All statistical comparisons were performed by a nonparametric test due to the limited number of subjects in each group (Mann-Whitney *U*-test, $P < .05$). The tests were carried out by using a commercial statistical package (SPSS for Windows, release 10.0.0, SPSS Inc).

RESULTS

Comparison of starting forms

No statistically significant difference was found in the craniofacial configurations at T1 in ETG and LTG when compared with ECG and LCG, respectively. All groups showed an average overjet of more than six mm and a full cusp class-II molar relationship.

Treatment effects in the ETG (Table 2)

Treatment with the Bionator appliance before the pubertal peak produced a significant overjet correction of 3.2 mm and a significant sagittal correction in molar relation of 2.6

mm when compared with growth changes in the ECG. The main contribution to occlusal correction was due to a smaller, though insignificant, increase in maxillary protrusion in ETG when compared with ECG. No other significant modifications were detected in the ETG during active therapy.

Posttreatment changes in the ETG (Table 3)

No significant modification was found during the posttreatment period in ETG when compared with ECG. Both overjet and molar relation remained virtually unchanged after Bionator therapy.

Overall treatment and posttreatment changes in the ETG (Table 4)

At the completion of the overall observation period, no significant difference in the dentoskeletal configuration of the patients treated before the pubertal growth spurt was recorded. Treatment produced an overjet correction of 1.6 mm and a correction in molar relation of 2.2 mm when compared with changes in the ECG.

Treatment effects in the LTG (Table 5)

Treatment with the Bionator appliance when the pubertal peak was included in the active treatment period induced a significant overjet correction of 4.4 mm and a correction in molar relation of 1.8 mm when compared with changes in the LCG. A significant mesial advancement of the mandibular dentition at both the molar and incisor regions occurred in LTG. At the skeletal level, supplementary increases in total mandibular length and in ramus height (of 4.3 mm both), along with a significant opening of the gonial angle and of the angle between the condylar line and the mandibular line, were found in LTG when compared with LCG.

Posttreatment changes in the LTG (Table 6)

As for ETG vs ECG, no significant modification was found during the posttreatment period in LTG when compared with LCG either. Both overjet and molar relation remained almost unchanged after Bionator therapy.

Overall treatment and posttreatment changes in the LTG (Table 7)

In the long term, the patients treated during the pubertal growth spurt showed a significant overjet correction of 4.2 mm and a correction in molar relation of 2.1 mm when compared with changes in the LCG. Significantly greater increments in total mandibular length (+5.1 mm) and in ramus height (+4.8 mm) were assessed in LTG when compared with LCG. These changes were associated with a significantly greater growth increment of the mandibular condyle in a backward direction in LTG, and with a significant opening of the gonial angle and of the angle be-

TABLE 2. Changes T2–T1 in the Early Groups^a

Variable	Early-Treated Group (ETG) (n = 13)		Early Control Group (ECG) (n = 11)		Mann- Whitney U-test	Group Difference ETG/ECG (Treatment Effect)
	Mean	SD	Mean	SD		
Cephalometric analysis (mm)						
Overjet (is/OL _p minus ii/OL _p)	-3.2	2.1	+0.0	2.0	S	-3.2
Molar relation (ms/OL _p minus mi/OL _p)	-2.9	2.0	-0.3	1.5	S	-2.6
Maxillary base (A point/OL _p)	+1.7	2.1	+3.6	1.9	NS	-1.9
Mandibular base (pg/OL _p)	+4.5	3.9	+3.7	2.2	NS	+0.8
Condylar head (co/OL _p)	+0.4	1.9	-0.7	1.2	NS	+1.1
Composite mandibular length (pg/OL _p + co/OL _p)	+4.1	3.9	+4.4	2.7	NS	-0.3
Maxillary incisor (is/OL _p minus A point/OL _p)	-0.4	2.1	-0.6	1.8	NS	+0.2
Mandibular incisor (ii/OL _p minus pg/OL _p)	-0.0	1.9	-0.7	0.8	NS	+0.7
Maxillary molar (ms/OL _p minus ss/OL _p)	-0.1	2.7	-0.4	1.5	NS	+0.3
Mandibular molar (mi/OL _p minus pg/OL _p)	0.0	2.0	-0.2	0.9	NS	+0.2
FMN-T point-ba (°)	-0.6	2.8	-0.6	1.4	NS	+0.0
FMN-T point-ar (°)	-1.0	2.1	-0.7	1.8	NS	-0.3
co-pg (mm)	+5.0	2.6	+4.2	2.8	NS	+0.8
co-go (mm)	+2.5	2.1	+2.6	2.7	NS	-0.1
go-pg (mm)	+3.1	1.7	+2.6	1.7	NS	+0.5
cl-ml (°)	+0.2	2.2	-0.4	1.4	NS	+0.6
ar-goi-me (°)	+0.8	1.9	-1.0	1.4	NS	+1.8
nl/FMN-T line (°)	+0.2	2.4	-0.3	1.9	NS	+0.5
ml/FMN-T line (°)	-0.3	2.3	-1.6	1.9	NS	+1.3
nl-ml (°)	-0.6	2.2	-1.3	1.5	NS	+0.7

^a S = significant comparison ($P < .05$); NS = not significant comparison.

TABLE 3. Changes T3–T2 in the Early Groups^a

Variable	Early-Treated Group (ETG) (n = 13)		Early Control Group (ECG) (n = 11)		Mann- Whitney U-test	Group Difference ETG/ECG (Posttreatment Changes)
	Mean	SD	Mean	SD		
Cephalometric analysis (mm)						
Overjet (is/OL _p minus ii/OL _p)	+0.0	1.1	-1.6	2.6	NS	+1.6
Molar relation (ms/OL _p minus mi/OL _p)	-0.7	2.0	-1.1	1.7	NS	+0.4
Maxillary base (A point/OL _p)	+2.6	2.3	+1.8	2.8	NS	+0.8
Mandibular base (pg/OL _p)	+6.8	3.7	+5.4	4.2	NS	+1.4
Condylar head (co/OL _p)	-1.3	1.7	-1.5	1.9	NS	+0.2
Composite mandibular length (pg/OL _p + co/OL _p)	+8.1	3.8	+6.8	3.6	NS	+1.3
Maxillary incisor (is/OL _p minus A point/OL _p)	+1.9	2.1	+0.3	2.7	NS	+1.6
Mandibular incisor (ii/OL _p minus pg/OL _p)	-2.3	1.7	-1.5	2.1	NS	-0.8
Maxillary molar (ms/OL _p minus ss/OL _p)	+2.5	3.8	+2.6	2.3	NS	-0.1
Mandibular molar (mi/OL _p minus pg/OL _p)	-1.0	2.5	+0.2	2.6	NS	-1.2
FMN-T point-ba (°)	-0.3	1.9	+0.4	2.2	NS	-0.7
FMN-T point-ar (°)	+0.4	2.5	+1.1	3.5	NS	-0.7
co-pg (mm)	+10.5	4.1	+9.3	3.4	NS	+1.2
co-go (mm)	+6.7	2.4	+6.1	2.0	NS	+0.6
go-pg (mm)	+6.7	3.3	+6.0	3.3	NS	+0.7
cl-ml (°)	-2.7	2.7	-2.2	2.4	NS	-0.5
ar-goi-me (°)	-4.2	3.3	-2.4	2.5	NS	-1.8
nl/FMN-T line (°)	-0.2	2.1	1.1	2.2	NS	-1.3
ml/FMN-T line (°)	-1.9	2.5	-0.8	2.0	NS	-1.1
nl-ml (°)	-2.1	3.0	-1.9	1.2	NS	-0.2

^a S = significant comparison ($P < .05$); NS = not significant comparison.

TABLE 4. Changes T3–T1 in the Early Groups^a

Variable	Early-Treated Group (ETG) (n = 13)		Early Control Group (ECG) (n = 11)		Mann-Whitney U-test	Group Difference ETG/ECG (Long-Term Changes)
	Mean	SD	Mean	SD		
Cephalometric analysis (mm)						
Overjet (is/OL _p minus ii/OL _p)	-3.2	2.7	-1.6	2.4	NS	-1.6
Molar relation (ms/OL _p minus mi/OL _p)	-3.6	1.5	-1.4	1.5	NS	-2.2
Maxillary base (A point/OL _p)	+4.3	2.5	+5.4	2.7	NS	-1.1
Mandibular base (pg/OL _p)	+11.3	5.1	+9.1	4.3	NS	+2.2
Condylar head (co/OL _p)	-0.9	1.7	-2.1	1.9	NS	+1.2
Composite mandibular length (pg/OL _p + co/OL _p)	+12.3	5.4	+11.2	2.9	NS	+1.0
Maxillary incisor (is/OL _p minus A point/OL _p)	+1.5	1.3	-0.2	2.6	NS	+1.7
Mandibular incisor (ii/OL _p minus pg/OL _p)	-2.3	1.8	-2.1	2.0	NS	-0.1
Maxillary molar (ms/OL _p minus ss/OL _p)	+2.5	4.4	+2.2	2.4	NS	+0.3
Mandibular molar (mi/OL _p minus pg/OL _p)	-0.9	3.3	0.0	3.0	NS	-0.9
FMN-T point-ba (°)	-0.9	2.4	-0.2	1.3	NS	-0.7
FMN-T point-ar (°)	-0.6	2.8	+0.4	2.4	NS	-1.0
co-pg (mm)	+15.4	4.9	+13.5	3.2	NS	+1.9
co-go (mm)	+9.2	3.0	+8.7	2.5	NS	+0.5
go-pg (mm)	+9.7	3.8	+8.6	2.9	NS	+1.1
cl-ml (°)	-2.5	2.5	-2.6	2.0	NS	+0.1
ar-goi-me (°)	-3.4	3.5	-3.3	2.2	NS	-0.1
nl/FMN-T line (°)	+0.4	2.2	+0.7	1.8	NS	-0.3
ml/FMN-T line (°)	-2.2	3.1	-2.4	2.9	NS	+0.2
nl-ml (°)	-2.7	3.4	-3.1	2.1	NS	+0.4

^a S = significant comparison ($P < .05$); NS = not significant comparison.

TABLE 5. Changes T2–T1 in the Late Groups^a

Variable	Late-Treated Group (LTG) (n = 10)		Late Control Group (LCG) (n = 10)		Mann-Whitney U-test	Group Difference LTG/LCG (Treatment Effect)
	Mean	SD	Mean	SD		
Cephalometric analysis (mm)						
Overjet (is/OL _p minus ii/OL _p)	-4.1	2.1	+0.3	1.1	S	-4.4
Molar relation (ms/OL _p minus mi/OL _p)	-2.2	1.7	-0.4	0.9	S	-1.8
Maxillary base (A point/OL _p)	+1.2	2.0	+1.2	1.6	NS	0.0
Mandibular base (pg/OL _p)	+2.1	5.8	+2.0	1.4	NS	+0.1
Condylar head (co/OL _p)	-1.7	1.7	-0.5	1.5	NS	-1.2
Composite mandibular length (pg/OL _p + co/OL _p)	+3.8	5.3	+2.5	2.0	NS	+1.3
Maxillary incisor (is/OL _p minus A point/OL _p)	-1.9	3.1	-0.3	2.3	NS	-1.6
Mandibular incisor (ii/OL _p minus pg/OL _p)	+1.3	2.1	-1.3	1.8	S	+2.6
Maxillary molar (ms/OL _p minus ss/OL _p)	+0.1	2.1	+0.3	1.6	NS	-0.2
Mandibular molar (mi/OL _p minus pg/OL _p)	+1.4	3.7	0.0	0.7	S	+1.4
FMN-T point-ba (°)	+1.2	1.6	+1.5	4.6	NS	-0.3
FMN-T point-ar (°)	+1.5	2.2	+1.2	3.3	NS	+0.3
co-pg (mm)	+7.2	4.9	+2.9	3.7	S	+4.3
co-go (mm)	+5.1	3.3	+0.8	3.1	S	+4.3
go-pg (mm)	+3.1	3.5	+3.2	3.6	NS	-0.1
cl-ml (°)	+1.2	2.0	-1.2	4.5	S	+2.4
ar-goi-me (°)	+0.5	1.8	-2.7	2.9	S	+3.2
nl/FMN-T line (°)	+1.6	2.4	0.0	1.7	NS	+1.6
ml/FMN-T line (°)	+1.3	2.1	-0.2	1.8	NS	+1.5
nl-ml (°)	-0.3	2.6	-0.2	1.6	NS	-0.1

^a S = significant comparison ($P < .05$); NS = not significant comparison.

TABLE 6. Changes T3–T2 in the Late Groups^a

Variable	Late-Treated Group (LTG) (N = 10)		Late Control Group (LCG) (N = 10)		Mann- Whitney U-test	Group Difference LTG/LCG (Posttreatment Changes)
	Mean	SD	Mean	SD		
Cephalometric analysis (mm)						
Overjet (is/OL _p minus ii/OL _p)	-0.5	1.4	-0.8	1.4	NS	+0.3
Molar relation (ms/OL _p minus mi/OL _p)	-0.6	1.6	-0.5	1.0	NS	-0.1
Maxillary base (A point/OL _p)	+0.4	2.6	+2.5	2.4	NS	-2.1
Mandibular base (pg/OL _p)	+4.8	4.1	+5.0	4.0	NS	-0.2
Condylar head (co/OL _p)	-1.8	1.6	-0.5	2.0	NS	-1.3
Composite mandibular length (pg/OL _p + co/OL _p)	+6.6	3.0	+5.5	4.4	NS	+1.1
Maxillary incisor (is/OL _p minus A point/OL _p)	+1.3	1.5	0.0	1.8	NS	+1.3
Mandibular incisor (ii/OL _p minus pg/OL _p)	-2.7	2.1	-1.7	1.9	NS	-1.0
Maxillary molar (ms/OL _p minus ss/OL _p)	+2.8	1.5	+2.1	2.2	NS	+0.7
Mandibular molar (mi/OL _p minus pg/OL _p)	-1.0	1.4	+0.1	2.1	NS	-1.1
FMN-T point-ba (°)	+0.6	2.7	-1.1	2.0	NS	+1.7
FMN-T point-ar (°)	+1.2	2.2	-0.5	2.1	NS	+1.7
co-pg (mm)	+7.1	2.7	+6.5	5.0	NS	+0.6
co-go (mm)	+4.9	2.4	+4.4	3.7	NS	+0.5
go-pg (mm)	+4.4	2.5	+4.1	4.7	NS	+0.3
cl-ml (°)	-1.4	2.3	-2.5	4.1	NS	+1.1
ar-goi-me (°)	-1.8	2.3	-1.8	4.5	NS	0.0
nl/FMN-T line (°)	+0.5	1.5	-0.5	2.8	NS	+1.0
ml/FMN-T line (°)	-1.6	1.9	-1.7	2.2	NS	+0.1
nl-ml (°)	-2.1	2.1	-1.2	2.6	NS	-0.9

^a S = significant comparison ($P < .05$); NS = not significant comparison.

TABLE 7. Changes T3–T1 in the Late Groups^a

Variable	Late-Treated Group (LTG) (n = 10)		Late Control Group (LCG) (n = 10)		Mann- Whitney U-test	Group Difference LTG/LCG (Long-Term Changes)
	Mean	SD	Mean	SD		
Cephalometric analysis (mm)						
Overjet (is/OL _p minus ii/OL _p)	-4.6	2.5	-0.4	1.2	S	-4.2
Molar relation (ms/OL _p minus mi/OL _p)	-2.9	1.9	-0.8	1.2	S	-2.1
Maxillary base (A point/OL _p)	+1.6	3.4	+3.8	2.9	NS	-2.2
Mandibular base (pg/OL _p)	+7.0	7.2	+7.0	4.6	NS	0.0
Condylar head (co/OL _p)	-3.4	2.5	-1.0	2.2	S	-2.4
Composite mandibular length (pg/OL _p + co/OL _p)	+10.4	6.1	+8.0	5.2	NS	+2.4
Maxillary incisor (is/OL _p minus A point/OL _p)	-0.6	3.2	-0.2	3.2	NS	-0.4
Mandibular incisor (ii/OL _p minus pg/OL _p)	-1.4	3.0	-3.0	2.6	NS	+1.6
Maxillary molar (ms/OL _p minus ss/OL _p)	+2.9	2.8	+2.5	3.2	NS	+0.4
Mandibular molar (mi/OL _p minus pg/OL _p)	+0.4	3.8	+0.1	2.5	NS	+0.3
FMN-T point-ba (°)	+1.8	3.7	+0.5	3.9	NS	+1.3
FMN-T point-ar (°)	+2.8	4.2	+0.6	3.2	NS	+2.2
co-pg (mm)	+14.4	5.4	+9.3	5.3	S	+5.1
co-go (mm)	+10.0	3.4	+5.2	3.7	S	+4.8
go-pg (mm)	+7.4	4.3	+7.3	3.2	NS	+0.1
cl-ml (°)	-0.2	1.9	-3.7	2.6	S	+3.5
ar-goi-me (°)	-1.3	2.4	-4.5	3.0	S	+3.2
nl/FMN-T line (°)	+2.1	3.0	-0.5	3.2	NS	+2.6
ml/FMN-T line (°)	-0.3	2.9	-1.9	2.8	NS	+1.6
nl-ml (°)	-2.4	3.2	-1.4	3.0	NS	-1.0

^a S = significant comparison ($P < .05$); NS = not significant comparison.

tween the condylar line and the mandibular line in the group that received treatment during the pubertal growth spurt.

DISCUSSION

Even though the Bionator has been part of routine functional appliance therapy for nearly four decades, surprisingly few methodologically sound clinical studies of this treatment approach, at least by today's standards, have appeared in the orthodontic literature. Although several cephalometric investigations on the short-term treatment effects of the Bionator appliance in growing subjects with class-II malocclusion have been published,⁴⁻⁸ no previous research has dealt with the issue of long-term response to this type of therapy. The only contribution that analyzed treatment outcomes of the Bionator in the long term is by Rudzki-Janson and Noachtar¹⁸ that does not include an untreated control sample for the appraisal of treatment effectiveness.

The need for adequate information regarding the long-term dentoskeletal modifications that can be produced by the Bionator appears compelling because the Bionator is one of the most commonly used appliances for functional jaw orthopedics. Furthermore, the efficiency of a given treatment protocol in dentofacial orthopedics has to be evaluated not only on the basis of treatment effectiveness but also for the issue of optimal treatment timing to achieve significant changes in the craniofacial structures. With these aims in mind, the present study analyzed the long-term skeletal and dentoalveolar changes after Bionator therapy in two different groups of class-II individuals at different stages of skeletal maturation.

The appraisal of skeletal maturity in both treated and untreated class-II samples was performed by the evaluation of growth stages in the cervical vertebrae, according to a recently modified version of the original CVM method. The original method has been used in previous papers^{16,17} to identify ideal treatment timing for other functional appliances such as the twin-block and the FR-2. In the present investigation, the newly developed CVM method^{19,20} (based on the evaluation of the morphological features of the second, third, and fourth cervical vertebrae only) was adopted to discriminate between a group of subjects treated before the onset of the pubertal spurt in mandibular growth (ETG) and a group of subjects who started treatment during the spurt (LTG). Both groups were reevaluated after the completion of growth (about six years after active treatment with the Bionator had been terminated). The posttreatment period in both early and late groups included a short phase of therapy with fixed appliances to refine and detail the occlusion.

The findings of the present study indicate clearly that significant long-term changes in the occlusal relationships and mandibular growth increments can be achieved by Bionator therapy only when functional treatment includes

the pubertal growth spurt. According to the new CVM method, these data indicate that functional jaw orthopedics with the Bionator should start not earlier than CVMS II (when a concavity is evident at the lower borders of both the second and third cervical vertebrae). In the long term, the late-treated subjects, who started Bionator treatment at the growth spurt, showed a significant improvement in the overjet (-4.2 mm) and a favorable change in the molar relation (-2.1 mm). The amount of supplementary elongation of the mandible in the LTG when compared with corresponding controls (5.1 mm) was two and a half times that of the ETG (1.9 mm), and it was produced almost entirely by Bionator therapy. Posttreatment changes were not significant. The greater increase in total mandibular length (co-pg) was associated with significant supplementary increases in the height of the mandibular ramus (co-go, 4.8 mm) in the group treated at the peak when compared with the corresponding control group, whereas only a 0.5-mm change for this measurement was recorded in the ETG. These results have significance not only at the statistical level but also are relevant clinically.

The significant supplementary growth of the mandible in the LTG was concurrent with favorable changes in both the anteroposterior position (co-OLp) and the growth direction (cl-ml) of the mandibular condyle. This growth modification has been described in the past as "posterior mandibular morphogenetic rotation,"¹⁴ a biological mechanism leading to greater increments in total mandibular length and, thus, efficiently improving the skeletal sagittal relationships in class-II malocclusion. In fact, the group treated during the pubertal growth spurt presented with all the cephalometric signs¹⁶ that demonstrate the effectiveness of functional treatment of skeletal class-II disharmony (1) increases in total mandibular length (co-pg), (2) increases in ramus height (co-go), (3) opening of the gonial angle (ar-goi-me), (4) posterior rotation of the condylar line in relation to the mandibular line (cl-ml), and (5) backward displacement of the condylar head in relation to the reference system (co-OLp).

Although not statistically significant, dentoskeletal modifications during active treatment with the Bionator appliance (T1-T2) deserve to be discussed to compare the short-term results of the present study with those reported by other investigators. The craniofacial changes, as evaluated in the T1-T2 interval in the total treated sample, examined in this study (23 subjects) approximate those found by Livieratos and Johnston²⁷ in their investigation of short-term effects of Bionator therapy as the first phase of comprehensive class-II correction.

When annualized, increases in mandibular length in both total treated and untreated samples in this study are similar to those reported in the randomized clinical trial by Tulloch et al.²⁸ Illing et al⁸ reported a two mm/y supplementary elongation of the mandible in treated subjects with respect to untreated controls, whereas Bolmgren and Moshiri⁶

found an increase of about 2.5 mm/y for the same measurement when compared with normative controls. The results of the present study confirm the possibility of producing about 2.5-mm/y additional increments in total mandibular length after Bionator therapy provided that treatment is initiated immediately before the pubertal growth spurt. Earlier treatment induces a clinically irrelevant change in mandibular growth (about 1 mm/y more than untreated controls).

A significant dentoalveolar advancement of the lower dentition in a mesial direction was detected in the late-treated sample in the short term. However, no significant movement of the dentition persisted in either of the treated groups in the long term. Earlier,⁶ capping of the mandibular incisors was recommended to prevent flaring of these teeth during therapy. The appliance design used in the present study did not include any capping of the lower incisors.

In recent times, the analysis of the effectiveness of the Bionator appliance when compared with the twin-block is becoming the most popular alternative clinical option for functional treatment of class-II malocclusion. The most favorable time period to start treatment with the twin-block is during or slightly after the peak in mandibular growth.¹⁶ The short-term supplementary mandibular increment that can be obtained with the twin-block at puberty is approximately 4.7 mm/y. A similar amount of additional mandibular growth when compared with untreated subjects is found in patients treated with the Bionator appliance at the pubertal growth spurt. However, in Bionator therapy this clinical result is achieved in a two-year time interval, which is twice the duration of the interval for active twin-block therapy. Regardless of the differences in both the mode of action and the clinical management of the two functional appliances, both the Bionator and the twin-block are effective therapeutic means for class-II treatment associated with mandibular deficiency. Nevertheless, the twin-block appears to be more "efficient" in terms of a shorter duration of treatment time interval (on average 14 months vs 22 months for the Bionator appliance).

Data regarding the long-term outcomes of twin-block therapy are needed for a definitive appraisal of the stability of the very favorable short-term dentoskeletal changes. Posttreatment stability appears to be a feature of Bionator therapy followed by fixed appliances to refine occlusion, both in prepubertal and pubertal patients. None of the skeletal parameters exhibited any relapse after active therapy in the present study. This finding is evident particularly in the LTG, which still showed small favorable changes even during the retention period.

CONCLUSIONS

The findings of the present long-term study on Bionator therapy followed by fixed appliances in class-II patients indicate that this treatment protocol is effective and stable

when it is initiated immediately before the pubertal growth spurt. Optimal timing to start treatment with the Bionator is when a concavity is evident at the lower borders of both the second and the third cervical vertebrae (CVMS II).

In the long term, the amount of significant supplementary elongation of the mandible in subjects treated with the Bionator during the pubertal growth spurt is 5.1 mm more than that in untreated subjects with class-II malocclusion. Similar favorable findings can be recorded for the significant increments in mandibular ramus height and for a significantly more backward direction of condylar growth.

ACKNOWLEDGMENTS

This article is dedicated to Professor Wilhelm Balters (in memoriam). The authors express their gratitude to Dr Carlos A. Kessner, Dr Cristina Ortolani-Faltin, and Dr Marcia A. A. Almeida for their assistance in this research project.

REFERENCES

- Balters W. Die Technik und Übung der allgemeinen und speziellen Bionator-Therapie. *Quintessenz*. 1964;Heft 5:77, IV.
- Balters W. *Einführung in die Bionator Heilmethode Ausgewählte Schriften und Vorträge*. Heidelberg: Drückerei Holzer; 1973.
- McNamara JA Jr, Brudon WL. *Orthodontics and Dentofacial Orthopedics*. Ann Arbor, Mich: Needham Press Inc; 2001:319–332.
- Janson I. A cephalometric study of the efficiency of the bionator. *Trans Eur Orthod Soc*. 1977;53:283–293.
- Janson I. Skeletal and dentoalveolar changes in patients treated with a Bionator during puberty and prepuberty. In: McNamara JA Jr et al., eds. *The Clinical Alterations of the Growing Face*. Ann Arbor, Mich: Center for Human Growth and Development, The University of Michigan; 1983:131–154.
- Bolmgren GA, Moshiri F. Bionator treatment in Class II, division 1. *Angle Orthod*. 1986;56:255–262.
- Mamandras AH, Allen LP. Mandibular response to orthodontic treatment with the Bionator appliance. *Am J Orthodont Dentofacial Orthop*. 1990;97:113–120.
- Illing HM, Morris DO, Lee RT. A prospective evaluation of Bass, Bionator, and Twin Block appliances. Part I—The hard tissues. *Eur J Orthod*. 1998;20:501–516.
- Lange DW, Kalra V, Broadbent HB, Powers M, Nelson S. Changes in soft tissue profile following treatment with the Bionator. *Angle Orthod*. 1995;65:423–430.
- Morris DO, Illing HM, Lee RT. A prospective evaluation of Bass, Bionator and Twin Block appliances. Part II—The soft tissues. *Eur J Orthod*. 1998;20:663–684.
- McNamara JA Jr, Bookstein FL, Shaughnessy TG. Skeletal and dental changes following functional regulator therapy on Class II patients. *Am J Orthod*. 1985;88:91–110.
- Malmgren O, Ömblus J, Hägg U, Pancherz H. Treatment with an appliance system in relation to treatment intensity and growth periods. *Am J Orthod Dentofacial Orthop*. 1987;91:143–151.
- Hägg U, Pancherz H. Dentofacial orthopaedics in relation to chronological age, growth period and skeletal development. An analysis of 72 male patients with Class II division 1 malocclusion treated with the Herbst appliance. *Eur J Orthod*. 1988;10:169–176.
- Petrovic A, Stutzmann J, Lavergne J. Mechanism of craniofacial growth and modus operandi of functional appliances: a cell-level and cybernetic approach to orthodontic decision making. In: Carlson DS, ed. *Craniofacial Growth Theory and Orthodontic Treat-*

- ment. Ann Arbor, Mich: Center for Human Growth and Development, The University of Michigan; 1990.
15. Petrovic A, Stutzmann J, Lavergne J, Shaye R. Is it possible to modulate the growth of the human mandible with a functional appliance? *Int J Orthod.* 1991;29:3–8.
 16. Baccetti T, Franchi L, Toth LR, McNamara JA Jr. Treatment timing for twin block therapy. *Am J Orthod Dentofacial Orthop.* 2000;118:159–170.
 17. Baccetti T, Franchi L. Maximizing esthetic and functional changes in Class II treatment by means of appropriate treatment timing. In: McNamara JA Jr, Kelly K, eds. *New Frontiers in Facial Esthetics.* Ann Arbor, Mich: Center for Human Growth and Development, The University of Michigan; 2001.
 18. Rudzki-Janson I, Noachtar R. Functional appliance therapy with the Bionator. *Semin Orthod.* 1998;4:33–45.
 19. Franchi L, Baccetti T. The use of maturational indices for the identification of optimal treatment timing in dentofacial orthopedics. In: McNamara JA Jr, Kelly K, eds. *Treatment Timing: Orthodontics in Four Dimensions.* Ann Arbor, Mich: Center for Human Growth and Development, The University of Michigan; 2002.
 20. Baccetti T, Franchi L, McNamara JA Jr. An improved version of the cervical vertebral maturation (CVM) method for the assessment of mandibular growth. *Angle Orthod.* 2002;72:316–323.
 21. Franchi L, Baccetti T, McNamara JA Jr. Mandibular growth as related to cervical vertebral maturation and body height. *Am J Orthod Dentofacial Orthop.* 2000;118:335–340.
 22. Riolo ML, Moyers RE, McNamara JA Jr, Hunter WS. *An Atlas of Craniofacial Growth: Cephalometric Standards From the University School Growth Study, The University of Michigan.* Ann Arbor, Mich: The Center for Human Growth and Development, The University of Michigan; 1974.
 23. Halazonetis DJ. Computer-assisted cephalometric analysis. *Am J Orthod Dentofacial Orthop.* 1994;105:517–521.
 24. Johnston LE Jr. A comparative analysis of Class II treatments. In: Vig PS, Ribbens KA, eds. *Science and Clinical Judgment in Orthodontics.* Ann Arbor, Mich: The Center for Human Growth and Development, The University of Michigan; 1986:103–198.
 25. Pancherz H. The mechanism of Class II correction in Herbst appliance treatment. A cephalometric investigation. *Am J Orthod.* 1982;82:104–113.
 26. Franchi L, Baccetti T, McNamara JA Jr. Treatment and posttreatment effects of acrylic splint Herbst appliance therapy. *Am J Orthod Dentofacial Orthop.* 1999;115:429–438.
 27. Livieratos FA, Johnston LE Jr. A comparison of one-stage and two-stage nonextraction alternatives in matched Class II samples. *Am J Orthod Dentofacial Orthop.* 1995;108:118–131.
 28. Tulloch JFC, Phillips C, Koch G, Proffit WR. The effect of early intervention on skeletal pattern in Class II malocclusion: a randomized clinical trial. *Am J Orthod Dentofacial Orthop.* 1997; 111:391–400.