

## **On the Correction of Liquid Precipitation**

Paper presented at the Nordic Hydrological Conference  
(Reykjavik, Iceland, August – 1986)

**P. Allerup and H. Madsen**

Danish Meteorological Institute, Copenhagen

The paper discusses a bi-linear statistical model for correcting aerodynamic errors, earlier presented by Allerup and Madsen, 1980. Further data from Finland, USA and Australia testing the model will be presented. A simplification of the bi-linear model in order to cover different gauge types and varying measuring levels will be demonstrated. The simplification will extend the applicability of the correction model when implemented into automatic correction systems.

The paper will discuss the problems of fit by the simplified model and attention will be given to physical interpretation of the mathematical structure in the model.

Besides aerodynamic errors, wetting losses influence the correction values. It will be demonstrated how these effects cause too large corrections for small amounts of precipitation and too small corrections for large amounts.

### **Introduction**

We have earlier worked out (Allerup and Madsen 1980) a statistical model for correction of liquid precipitation due to aerodynamic errors, i.e. a statistical model to evaluate the ratio of the daily amounts of precipitation measured in a standard gauge (Hellmann) placed at 1.5 m height and in a reference gauge (Snowdon) placed at ground level. The model was developed on data from Denmark. The loss due to aerodynamic errors was estimated by a statistical model, in which two parameters must be known: wind speed at gauge rim and rain intensity.

Correction of precipitation values in Denmark, both historical data and future observations can henceforth be carried out by applying this model, since the standard gauge in Denmark is a Hellmann gauge placed 1.5 m above ground level. When the gauge type is not a Hellmann or the measuring height is not 1.5 m, we are therefore unable to evaluate actual corrections by means of standard correction tables for the 1.5 m Hellmann.

In connection with a general WMO project on correction of precipitation (Sevruk 1985) we had access to data collected in other countries, under different gauge conditions and we have already presented our first analyses (Allerup 1985) of data contributed by Finland to this WMO-project. It showed to be a bad analytic strategy just to follow the statistical analyses done on the first set of Danish data, i.e. to duplicate the structure of the statistical model with updated 'constants' (coefficients for Finland). We therefore developed a simplification of the original model, apted for such comparisons, and an attempt to interpret one of the parameters of this simplified so-called 'meeting point' model was done.

This paper proceeds along the same lines in order to obtain a general expression for the correction of precipitation values due to aerodynamic errors. We have used data sets collected in Australia and USA, which in combination with the data already analysed in Denmark and Finland constitutes a suitable variety of gauge types and gauge heights to test the existence of a general mathematical structure.

Alongside these studies, we have touched three topics in connection with the practical use of the correction model: the *effect* on corrections from a shield, *where* to measure rain intensity (distance from gauge to be corrected) and, finally the *influence* of wetting on determination of the aerodynamic error (Madsen 1985).

## Instrumentation and Site

Information about the instruments used by these comparisons are given in Table 1. The national raingauges are of different types (see Fig. 1) placed at various heights above ground level. The reference is a 127 cm<sup>2</sup> W5000/1 Snowdon raingauge installed in a pit with its orifice at ground level and surrounded by a grid preventing splash-in.

Rain intensity is measured in a pluviograph, placed near the raingauges. Wind *during* precipitation is also measured, but only at the two stations in U.S.A. The wind is recorded at gauge rim (see Table 1). For the other stations data of wind speed has been adjusted to height of the national gauge before analysis.

-In order to study the effect of a shield a comparison of a shielded and an unshielded gauge (Hellmann) has been undertaken at Skrydstrup in Denmark.

All sites are flat within a distance of 30 m in all directions from the gauges, and covered by short grass, free from bushes, trees, and buildings.

## On the Correction of Liquid Precipitation

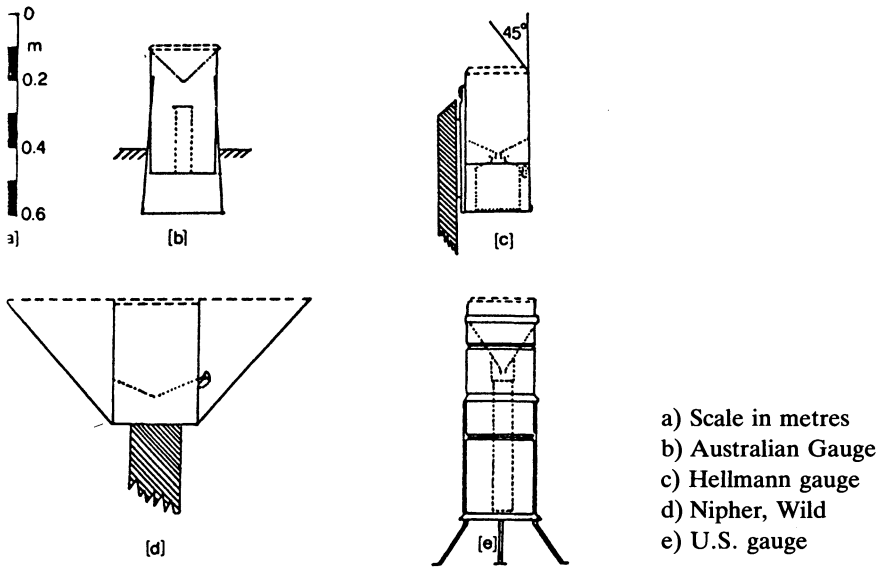

Fig. 1. National raingauges. From Sevruk and Hamon (1984).

Table 1 – Data on gauge types and instrumentation

Country	Australia	Denmark	Finland	U.S.A.
Station	Ceduna Rabaul	Skrydstrup	Jyväskylä	Sterling Swan Island
National gauge measuring height (m)	Aust.STD. (203 cm <sup>2</sup> ) 0.3	Hellmann (200 cm <sup>2</sup> ) 1.5	Nipher, Wild (500 cm <sup>2</sup> ) 1.5	U.S.Std. (324 cm <sup>2</sup> ) 0.9
Pit gauge	Snowdon	Snowdon	Snowdon	Snowdon
Other gauges measuring height (m)		Hellmann shielded (200 cm <sup>2</sup> ) 1.2		
Pluviograph measuring height (m)	0.9	1.0	1.1	0.9
Wind measuring height (m)	2.0	10.0	10.0	1.0

Table 2 – Frequency of precipitation observations for the national gauge and the pit gauge.

Country,	Station	Observations	
		number	frequency of measurement
Australia	Ceduna	66	semidaily
	Rabaul	142	semidaily
Denmark	Skrydstrup	301	daily
Finland	Jyväskylä	151	daily
U.S.A.	Sterling	91	semidaily
	Swan Island	227	semidaily

### Data

The data for this analysis include daily or semidaily values of amounts of *liquid* precipitation measured at the national gauge and in a pit gauge (see Table 2). For each of these values the average rain intensity and the average wind speed during rainfall is calculated according to Sevruk and Hamon (1984). The rain intensity is defined as the ratio between the total amount of precipitation and the total duration (mm/hour). Wind speed is calculated from standard hours of synoptic observations, where precipitation has been simultaneously observed.

### The Fit of Correction Models

Data from the six measuring sites were arranged into one big file, and our first analysis were directed towards the fit by the general, bi-linear model (Allerup and Madsen, 1980).

#### Bi-linear Model

$$\frac{P_{pg}}{P_{ng}} \equiv e^{\Psi(I, V)}; \quad \Psi(I, V) = \alpha_1 \ln I + \alpha_2 V \ln I + \alpha_3 V + \alpha_4 \quad (1)$$

here  $P_{pg}$  – pit gauge,  $P_{ng}$  – national gauge,  $I$  – rain intensity (0.1 mm/hour), and  $V$  – wind speed at gauge rim (m/sec).

Estimation of empirical corrections  $P_{pg}/P_{ng}$  – or the relative corrections  $\Delta P/P_{ng}$  – were carried out on Danish data, only in our first analyses. When all 1,000 observations (approx.) from the six gauges were fitted by Eq.(1), we arrived at  $\alpha$ -coefficients very near the values originally found in the Danish data set. In fact, the maximum likelihood estimates were:

## On the Correction of Liquid Precipitation

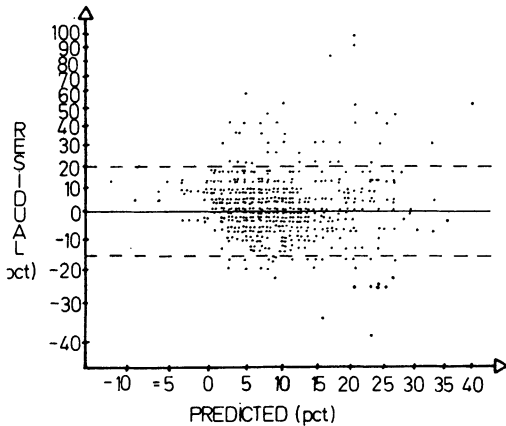

Fig. 2. Residual values (ordinate) versus predicted theoretical correction values (abscissa) by means of the bi-linear model.

	$\alpha_1$	$\alpha_2$	$\alpha_3$	$\alpha_4$
Original, Danish data:	-0.0010	-0.0082	0.0420	0.0100
All data from six gauges:	-0.0013	-0.0097	0.0457	0.0277

The degree of equality between the two sets of parameters is striking, since we are trying to fit *all* six gauges at one time. Fig. 2 demonstrates the quality of fit, and it is seen, however that the error (variance) on model calculated corrections is increasing with increasing level of correction. Other graphical control plots of the bi-linear model reveals the surprising fact, that it is the Danish data, which have the relative poorest fit. From Fig. 2 it is further seen, that 95 % of residual errors are within the limits  $\pm 15\%$  (approx.), providing a residual mean square error  $\sigma^2 \approx 0.0098$ . In comparison, the earlier fit by the bi-linear model resulted in a  $\sigma^2 \approx 0.0149$ .

### Meeting Point Model

In an earlier study (Allerup 1985), where approx. 150 measurements from Finland were analysed by means of the bi-linear model, we did not expect the shielded Finnish Wild gauge to behave like the Danish unshielded Hellmann gauge – in the sense of equal  $\alpha$ -parameters. In order to create a more flexible, mathematical framework for such comparisons than constituted by the bi-linear model, and because it was observed by several occasions, that a simplifying relationship exists among the  $\alpha$ 's, we proposed (Allerup 1985) the following refinement of the bi-linear model, called the meeting point model

$$\frac{P_{pg}}{P_{ng}} \equiv \left( \frac{I_0}{I} \right) \tau(V) \quad (2)$$

The rationale for the structure of this model is given in detail in Allerup (1985).  $I$  is the rain intensity (mm/hour),  $\tau(V)$  a general function of wind speed  $V$  (m/sec) and  $I_0$  is the limiting value ('the meeting point') above which it is assumed that  $P_{pg} = P_{ng}$  – irrespective of the wind speed! Notice, that the specification Eq.(2) includes  $\tau(V)$

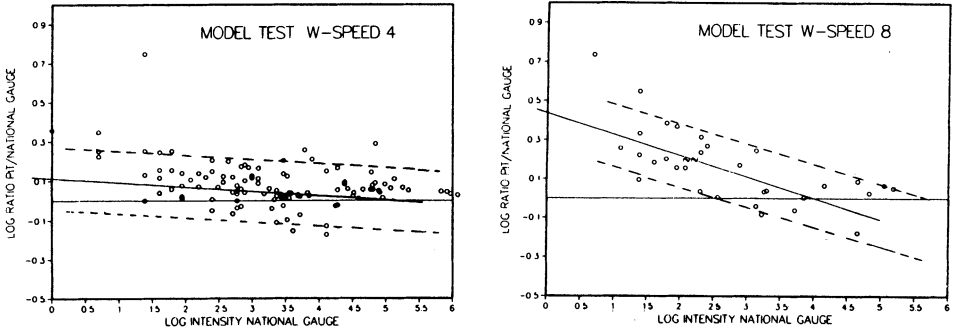

Figs. 3-4. Relation between  $\log P_{pg}/P_{ng}$ , logarithmic observed correction (ordinate) versus  $\log I$ , logarithmic rain intensity. Wind speed  $\equiv 4$  and  $8$ .

as a general function, which as a special case might be simplified to something linear in the wind speed itself – like the bi-linear model.

Encouraged by the bi-linear fit to *all* data we tried – in spite of experiences given in Allerup (1985) – to fit Eq.(2) to *all* data. Basic to verification of the fit lies a series of plots (see Allerup 1985) where  $\log (P_{pg}/P_{ng})$  is studied as function of  $\log I$  – for fixed wind speed. Fig. 3 and Fig. 4 give two examples on this fit. Wind speeds from  $V=0$  to  $V=12$  are present in data (although  $V \geq 9$  is seldom observed) and the over all impression from the control plots is, that the straight-line structure between  $\log (P_{pg}/P_{ng})$  and  $\log I$ , which is postulated by the model, is actually found – as demonstrated in Fig. 3 and Fig. 4.

The intercept value on the abscissa is  $\log I_0$  – and the slopes of the straight lines – i.e.  $1-\tau(V)$  – lead to estimates:  $\hat{I}_0$  and  $\hat{\tau}(0), \hat{\tau}(1), \dots, \hat{\tau}(8)$  which are further analysed in Fig. 5.

It is seen from Fig. 5, that the function  $\tau(V)$  is quite well approximated by a simple, straight line – like the situation in Allerup (1985). Two approximations have been applied to the points, the one (b) being straight forward least square estimates, the other, (a) is based upon inspection of the plots, whereupon outliers are disregarded. In both cases we consequently have a *linear* structure.

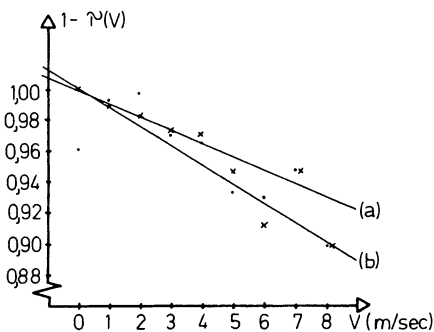

Fig. 5.

Linear approximation to the general wind function  $\tau(V) V=1, \dots, 8$ . All data  $\hat{I}_0=150$ . Least square estimates of intercept and slopes: “.” (b), corrected for outliers “x” (a).

## On the Correction of Liquid Precipitation

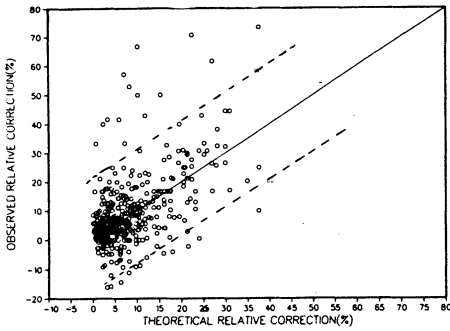

Fig. 6.  
Observed and model-calculated corrections (relative in pct.) for the meeting point model. All data.  $I_0=150$ .  $\kappa=0.01100$ .

$$\tau(V) = \kappa V \quad \text{where } \kappa \equiv \begin{cases} 0.00875 & \text{(a)} \\ 0.01100 & \text{(b)} \end{cases} \quad (3)$$

If we use the linear approximation (b) and the estimated  $I_0$ -value = 150 in the meeting point model, Eq.(2) we can now calculate for *all* data the difference between observed corrections and theoretical corrections from the model. The result is displayed in Fig. 6. Notice, that the complete data set include cases with  $P_{pg} < P_{ng}$  (negative relative correction) while the model always produces positive values. Approximative 95% bounds are dotted lines, and it becomes noteworthy again, that the marked deviations above the upper bound are nearly all of them part of the Danish data set (which, however constitutes 1/3 of all data!). The bounds set up limits being not far from the residual limits in the bilinear model (cf. Fig. 2.)

We must conclude, therefore that the meeting point variant of the general bi-linear correction model seems to work well, structurally against all gauge data. This is surprising, since marked differences arising from different gauge types was expected.

It was earlier demonstrated (Allerup 1985) that the full, actual table of corrections used for correcting Danish gauges could be reproduced up to almost numerical equality. This is, in fact done with  $I_0 = 150$  and  $\kappa = 0.00875$ , the outlier-corrected  $\kappa$  (a), but the Danish data set is in fact much responsible for the points with high wind speeds in Fig. 5. Future work will be concentrated on analysing the evidently small, systematic differences in  $I_0$  and  $\kappa$  values for the different gauge types. Hopefully, this will result in a further reduction of the single gauge estimation error.

### The Effect of a Shield

Before entering data from all measurements into one pool, it was necessary to study especially the way a shield affects the aerodynamic circumstances around the gauge, since many countries use a shield as standard equipment. The effect of a shield is well-studied (Bolshakov 1974, Sanuki *et. al.* 1952, Sevruck 1983, and War-

nick 1953 and 1954), but attention is often given to catch errors conditioned upon wind speed as the only aerodynamic factor.

Since our purpose is to correct standard precipitation measurements as function of both wind speed and rain intensity it follows, that the study of shield effect has to be extended beyond the existing studies in order to include both aerodynamic factors in the description. Three theoretical possibilities emerge immediately from such a study. Specifying the 'effect' to be the difference between measurements from a shielded and an unshielded gauge (same type of gauge placed at same height and with same external influence by shelter...ect.) we have to end up with one of the following three situations:

- i) The effect is a very complex function, outside "our" correction function – but still a function of wind speed and rain intensity, possibly depending upon physical shield characteristics.
- ii) The effect is simple to describe by means of the same correction function, i.e. same *mathematical* structure, as used to correct unshielded measurements in relation to true ground catch.
- iii) The effect is not at all depending on the aerodynamic factors wind speed and rain intensity, but may be due to *some* shield effect not described by the aerodynamic factors as variables. – This case could be obtained from ii), with all coefficients to aerodynamic factors equal to zero.

In case of ii) the shield effect can be compared with measurements of precipitation values from two unshielded gauges (at same height) with some interdistance.

Data for this study were approximately 300 simultaneous measurements from a shielded and an unshielded gauge (interdistance less than 10 m) used earlier in the construction of the bi-linear correction model (Allerup and Madsen 1980).

Figs. 7 and 8 demonstrate the relations between rain intensities (log-values) for two extremes: *heavy* wind speed,  $\geq 10$  m/sec and *low* rain intensity,  $\leq 1.0$  mm/hour, in which case a large effect should be expected and another example with 'no' wind,  $\leq 4$  m/sec and 'big' rain drops (intensity  $> 1.0$  mm/sec), in which case the effect of shield should be infinitesimal. Inspection of the two figures – and the figures corresponding to other wind speed and rain intensity combinations – shows, that the points are distributed evenly around the *identity* line, or a little in favour of the shielded gauge. It is, however clear that the structure *is* a straight line, which immediately leads us to conclude, that the shield effect is really within the reach of our correction model. In other words, data from a shielded gauge can be used parallel with unshielded gauge data in our correction model.

It is amazing to observe so little difference between the shielded and unshielded catch. Furthermore, the little over-catch in the shielded gauge could be ascribed to the fact, that the shielded gauge is placed a little *lower* than the unshielded gauge (1.2 m versus 1.5 m), resulting in less wind speed at gauge rim.



## On the Correction of Liquid Precipitation

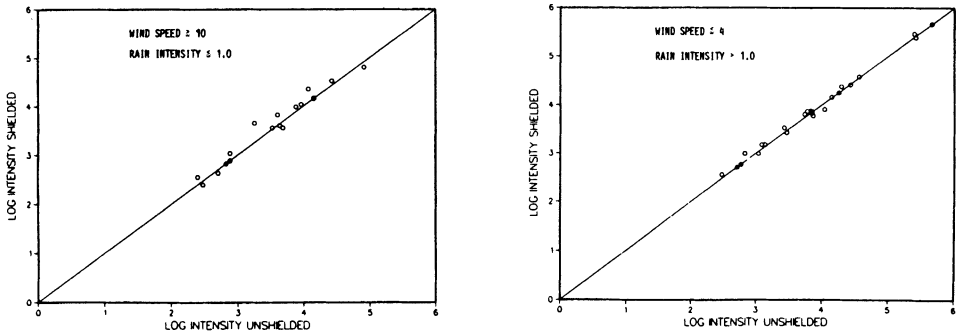

Figs. 7-8. Relation between log-intensities for two extreme situations.

To summarize, we are led to conclude that the shielded gauge is like any other gauge, and that the shield does not protect the gauge *in terms of* wind speed or rain intensity. It seems that the major effect of the shield has been to introduce 'noise' into the catch ability – in fact the points in Figs. 7 and 8 are distributed *around* the line, not *on* the line.

### Model Sensitivity and Change of Rain Intensity

Since the correction model is dependent on rain intensity, it is of interest to see how sensitive the model is towards changes in this parameter. Rain intensity is not always at hand near the measuring site – in contrast to wind speed measurements – and the practical usage of our correction models is therefore dependent on how far from the gauge to be corrected one can go to collect reliable intensity measurements.

We have studied this problem of obtaining 'representative' rain intensity measurements by selecting two parallel one-year precipitation series at two sites in the neighbourhood of Copenhagen, with interdistance approx. 10 km. The gauges are both recording raingauges and we have read out from the files: *total* amount of precipitation in one day (possibly summing over more than one event) and *total* number of minutes during rain in accordance with Allerup and Madsen (1980).

A simple visualization of the variation between the two rain intensity measurements can be obtained from the logarithmic difference between the intensities. This is given in Fig. 9 and it is seen, that the maximal differences are  $\approx 1.1$  (positive) and  $\approx 1.90$  (negative). Apart from these two extremes, which might be 'outliers', the differences are distributed evenly around zero. In fact,  $2/3$  of the points corresponding to  $\pm$  one standard deviation limits are found in the interval  $[-0.50, 0.50]$ .

For the bi-linear model Eq.(1) this means, that correction values for the Hellmann gauge at 1.5 m will vary according to a change in the log-intensity up to  $\pm$

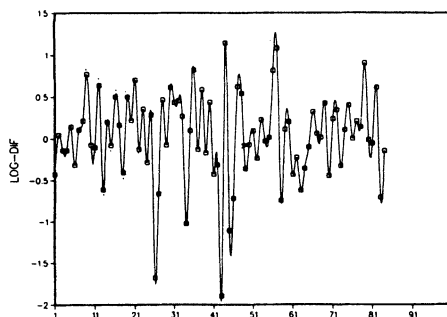

Fig. 9. Logarithmic difference (ordinate) between rain intensities measured 10 km apart. The abscissa is observation number.

0.50. By inserting the change  $\log I \rightarrow \log I \pm 0.50$  into the bi-linear model Eq.(1) we get

$$B \text{ corr} (I, u) \rightarrow e^{\Psi(I, V)} e^{\pm(0.0005+0.0041 V)} - 1 \tag{4}$$

where  $\psi(I,u)$  is the basic correction function. The over all changes  $\exp \pm(0.0005 + 0.0041V)-1$  are listed in Table 3.

If we apply the meeting point model the calculations can be given a more general form. In fact, still taking  $\log I \rightarrow \log I \pm 0.5$  as the basic transference of log intensities from the 10 km-away site to the correction site, we end up with the following formula for the meeting point corrections

Table 3 – Correction values calculated from the two correction models and  $\pm$ pct. deviations resulting from error on rain intensity measurements taken 10 km away.

Wind speed, V (m/sec)		Correction (%) calculated directly from the <i>meeting point</i> model		$\pm$ pct. deviation in relation to actual correction value		
		Intensity (mm/h) I = 0.8	I = 2.5	Intensity (mm/h) I = 0.8	I = 2.5	
I <sub>0</sub> =20.0	4	14%	9%	$\pm 1.9\%$	$\pm 1.9\%$	
	10	35%	23%	$\pm 5.1\%$	$\pm 5.1\%$	
	18	78%	45%	$\pm 9.3\%$	$\pm 9.3\%$	
I <sub>0</sub> =10.0	4	11%	6%	$\pm 1.9\%$	$\pm 1.9\%$	
	10	29%	15%	$\pm 5.1\%$	$\pm 5.1\%$	
	18	58%	28%	$\pm 9.3\%$	$\pm 9.3\%$	
Wind speed, V (m/sec)		<i>Bi-linear</i> model		$\pm$ pct. deviation		
		Intensity (mm/h) I = 0.8	I = 2.5	Intensity (mm/h) I = 0.8	I = 2.5	
		4	11%	7%	$\pm 1.7\%$	$\pm 1.7\%$
		10	29%	18%	$\pm 4.7\%$	$\pm 4.7\%$
		18	58%	33%	$\pm 7.7\%$	$\pm 7.7\%$

## On the Correction of Liquid Precipitation

$$M_{\text{corr}}(I, V) \equiv \frac{P_{pg}}{P_{ng}} \rightarrow \left( \frac{I_0}{I_{ng}} \right)^{\tau(V)} q^{-\tau(V)} \quad (5)$$

where  $q = \exp(\pm 0.50) = 1.64$  or  $0.61$ . Note that this value is independent of  $I_0$ . We can tabulate the effect,  $q^{-\tau(V)}$  of transferring the rain intensity measurements, and for the sake of simplicity assume, that  $\tau(V) = 0.01V$ , which is the wind function valid for the unshielded 1.5 m Hellmann gauge. The results are presented in Table 3 together with the Bcorr-results from the bi-linear model.

From Table 3 it is seen, for instance that with  $V = 18\text{m/sec}$  and rain intensity  $I = 0.8\text{mm/h}$  the correction value using the bi-linear model is 58% – but due to the spatial variability, when taking rain intensity 10 km away, we may modify the ‘guess’ to  $58\% \pm 7.7\%$ . We apply  $\pm 1$  standard deviation limits on the estimate of the ‘true’ rain intensity at the gauge.

Summarizing the results we see, that the effect of transferring measurements of rain intensity to a place approx. 10 km away is a change of the correction value from about  $\pm 2\%$  on a 10% level to  $\pm 10\%$  on a 50-75% correction value level. It is further seen, that for the gauges with  $I_0 = 10.0$  the ‘damage’ due to transference is larger, since low  $I_0$ -values generally lead to lower absolute correction values.

### Influence of Wetting on Determination of the Aerodynamical Error

In Denmark correction of the aerodynamical error of liquid precipitation is based on the ratio  $P_{m0}/P_{m1.5}$  between *measured* precipitation at ground level  $P_{m0}$  and *measured* precipitation at standard height  $P_{m1.5}$  (Allerup and Madsen 1980). However, this ratio is influenced by wetting and evaporation losses. While the latter is very small the wetting loss was found to amount about 4% of annual precipitation. Measured precipitation may thus be expressed as collected precipitation reduced by wetting losses  $\Delta P_w$ , which are approximately equal for measurements at ground level and standard height 1.5 m.

$$P_{m0} \approx P_{c0} - \Delta P_w \quad \text{and} \quad P_{m1.5} \approx P_{c1.5} - \Delta P_w \quad (6)$$

The ratio of *collected* precipitation may be expressed as

$$\frac{P_{c0}}{P_{c1.5}} = \frac{P_{c1.5} + \Delta P_a}{P_{c1.5}} = 1 + \frac{\Delta P_a}{P_{c1.5}} \quad (7)$$

where  $\Delta P_a$  is the aerodynamic error due to measurements being taken at 1.5 m. Since  $\Delta P_a$  is the only systematic error in Eq.(7) it is really this ratio which should be studied to evaluate corrections to precipitation measurements. However, in order to obtain  $P_{c0}$  and  $P_{c1.5}$  the precipitation must be weighted, but such recordings have not been carried out.

The ratio for measured precipitation may be stated as

$$\frac{P_{m0}}{P_{m1.5}} = \frac{P_{m1.5} + \Delta P_{\alpha}}{P_{m1.5}} = 1 + \frac{\Delta P_{\alpha}}{P_{m1.5}} \approx 1 + \frac{\Delta P_{\alpha}}{P_{c1.5} - \Delta P_w} \quad (8)$$

By comparing the last term in Eqs.(7) and (8), which is the relative correction due to the aerodynamic error, we note that the wetting loss  $\Delta P_w$  enters into the correction for measured precipitation Eq.(8), and we found that the wetting losses influence the correction of aerodynamical errors for measured precipitation causing too large corrections of small amounts of precipitation and too small corrections for large amounts.

### **Closing Remarks**

Many investigators have dealt with the problem of undercatch of rainfall by rain-gauges due to the aerodynamic effect, but a physical explanation is incomplete. Folland (1985) has tried to explain and predict the losses of rainfall from a raingauge by using a two dimensional model mainly based on experiments carried out by Robinson and Rodda (1969) and Green and Helliwell (1972). He shows that an overwhelming contribution to exposure losses comes from the smallest raindrops. Bugge and Maribo Pedersen (1976) whom we formerly contacted also concluded that the aerodynamic effect was infinitesimal for other than very small raindrops.

Folland has compared the model results with our field results (Allerup and Madsen 1980), and he finds a very good agreement in the rainfall losses over the wide range of wind speeds during rainfall and rain intensity.

For the application of the correction model in Denmark, the total area is subdivided into 12 subregions each of them being so homogeneous as possible with respect to the precipitation pattern. A telemetering network with automatic stations (basic station) measuring wind speed and rain intensity placed in the center of the subregions is under construction. Monthly precipitation values from all stations within such a subregion will then be corrected by a calculated monthly correction value based on data from the automatic station.

### **Conclusions**

These analyses were aimed at testing two versions of correction models for aerodynamic errors. It was expected from earlier experience, that analysis of several gauge types, shielded and unshielded would lead to strongly varying coefficients in the bi-linear general correction model. It turned out, that a reasonable fit by the bi-

## *On the Correction of Liquid Precipitation*

linear model to *all* gauges could be obtained and also the more specialized version, the meeting point model could fit all data, too. The stronger mathematical framework offered by the meeting point model will be the future base for looking into detailed differences between the analysed gauge types.

### **References**

- Allerup, P., and Madsen, H. (1980) Accuracy of point precipitation measurements, *Nordic Hydrology, Vol. 11*.
- Allerup, P. (1985) On the construction and fit of a statistical model for aerodynamic errors in point precipitation measurements. Proceedings of WMO/IAHS Workshop on corr. of Precipitation Measurements, Zürich.
- Bolshakow, A. B. (1974) Experimental investigations of the aerodynamic properties of the wind shields of precipitation gauges, Transactions of the Main Geophysical Observatory, Trudy GGO2, Vol. 340.
- Bugge, J. A. C., and Maribo Pedersen, B. (1976) Vindens indflydelse på vandopsamlingen i regnmålere. Afd. F. Fluid Mech. Den polytekniske Lærestalt, Lyngby (in Danish).
- Folland, C. K. (1985) A simple numerical model of the loss of rainfall catch from a standard 5" gauge due to wind. Proceedings of WMO/IAHS Workshop on corr. of Precipitation Measurements, Zürich.
- Green, M. J., and Helliwell, P. R. (1972) The effect of wind on the rainfall catch. WMO/ OMM No 326 Vol. II.
- Madsen, H. (1985) Influence of wetting on determination of the aerodynamical error. Proceedings of WMO/IAHS Workshop on corr. of Precipitation Measurements, Zürich.
- Robinson, A. C., and Rodda, J. C. (1969) Rain, wind and the aerodynamic characteristics of raingauges, *Met. Mag., Vol. 98*.
- Sanutki, M., *et. al.* (1952) Water tank on wind tunnel tests on raingauge wind shield. Papers in Meteorology and Geophys. Vol. III, No 1.
- Sevruk, B. (1983) Correction of measured precipitation in the Alps using the water equivalent of new snow, *Nordic Hydrology, Vol. 14(2)*.
- Sevruk, B., and Hamon, W. R. (1984) International comparisons of national precipitation gauges with a reference pit gauge. WMO Instruments and Observing Methods Report No. 17.
- Sevruk, B. (1985) ETH/IAHS/WMO Workshop on corr. of Precipitation Measurements, Zürich 1-3 april.
- Warnick, C. C. (1953) Experiments with windshields for precipitation gauges. Transactions, *American Geophys. Union, Vol. 34, No. 3*.
- Warnick, C. C. (1954) Discussion of 'Experiments with windshields for precipitation gauges', *Transactions, American Geophys. Union, Vol. 35, No. 3*.

Received: 1 October, 1986

*On the Correction of Liquid Precipitation*

**Address:**

Danish Meteorological Institute,  
Lyngbyvej 100,  
DK-2100, Copenhagen,  
Denmark.