

## Designing a new flushing machine: a compromise between tradition and modernity

J. Cardinaud\* and M. Martaud\*\*

\* SIAAP, Service de l'Assainissement de Paris, 9 rue Schoelcher 75675 PARIS cedex 14, France.

\*\* SAFEGE Consulting Engineers. PO Box 727. 92007 NANTERRE Cedex France.

**Abstract** Sewer cleaning has always been difficult and unhealthy work. Paris had to contrive, for sewer men, specific flushing units for removing grit from its interceptors. These machines, which are over a hundred years old and only take power from the water flow, could not be replaced by more mechanised systems based upon different concepts. It appears from these setbacks that all the connections with the past should not be severed; on the contrary, one should initiate a process relying upon a thorough review of the existing equipment and a new approach to in-water grit flushing. The resulting data then served as a basis for devising the concept of a new flushing machine which, though not revolutionary, will meet the operators' expectations.

**Keywords** Sewerage; interceptors; flushing; mechanisation; autonomous; measurements; physical model

### Introduction

E. Belgrand, who conceived the Paris sewerage system, had adopted the principle of a fully visitable gallery network globally collecting rain, waste and industrial waters that were carried through gravity flow downstream from Paris and were discharged into the river Seine. Since the galleries have gentle slopes and also collect runoff and street washing waters, they soon were filled with grit.

The daily job of workmen, who were given the name "sewer men" in that time, consisted in manually removing the growing grit banks. The engineers soon felt that more "mechanical" flushing means had to be contrived. E. Belgrand also invented the flushing machines that travel along the gallery network.

So-called gate boats and gate cars were initially developed as far back as 1860; the machine concept was always the same: a carriage- or barge-mounted gate conforming with the cunette shape creates a moving dam. Water is forced under that gate which then releases a jet that washes sediment away. The sediment builds up in the form of a mound ahead of the machine and is shifted by the fluid stream down to the grit chambers. Sewer men used these machines for generations up to 1985, when the sewer system upgrading was contemplated.

In that time, the report had concluded that considering the large amounts of grit in main sewers, the low performance level of flushing and the difficulty of the job, further machines actuated by much more powerful external sources of energy were to be devised.

The first new machine, referred to as CIRCE, was tested in the Clichy interceptor (see Figure 1). It was powered by a powerful above-ground hydraulic power plant and could dredge grit that was subsequently crushed, bagged and taken away. In the light of that promising process, the Department invited tenders for dredging the Marceau interceptor in 1990, the challenge consisting in removing 6,000 cu.m of grit over 3 kilometres. The successful tenderers suggested resuming the utilisation of CIRCE on a permanent basis downstream from the interceptor which is located at the boundary of Paris, wherefrom the grit is to be extracted.

The grit was collected by another machine, which was known as VAN. That machine was provided with a wheel train fitted with a camber angle onto a horizontal axis and



**Figure 1** Mechanised flushing machine, referred to as CIRCE

rotating in the cunette. VAN supposedly resuspended the grit that was subsequently shifted by VAN running at high speeds along the footways. The machine advance was soon halted due to the compaction of grit and the occurrence of heavy bodies, such as stones, iron scrap . . . which it could not shift.

Though the CIRCE was more powerful than it was initially, it came up against the problem of heterogeneous materials to be sorted and crushed. A lot of effort was expended for over two years, but only 2,000 cu.m of sediment was removed from the interceptor, then the work had to be dropped whereas it should have been completed in six months. Flushing was resumed later on using the conventional gate boat method.

Through that failure, it became obvious that supplying thermal energy was an awkward task in sewers. That technology involves expensive machines that do not properly fit the environment (overall dimensions, water swelling, confined atmosphere) and have much lower than expected flushing efficiencies.

Mechanisation was indeed attractive for such stationary facilities as the grit settling basins; on the contrary, it seemed to be more disadvantageous than profitable for machines aiming at replacing the one hundred years old flushing equipment.

Such findings could not meet anybody's expectations. The Service de l'Assainissement de Paris (Paris sewerage Department) then came back to one of its earliest ideas: can the existing equipment be upgraded? The operators had always negatively answered that question, putting forward the reason that all the machines had gradually been modified. In their eyes, these quite empirical changes had led to a maximum rationalisation.

In order to find an actual way of upgrading, the study was resumed from its very beginning – analysing the flushing process as produced by the machine, quantifying the equipment efficiency.

### **Objectives of the study**

The study programme aimed at the following.

1. Preparing a report on an existing machine having a well known efficiency at the beginning of the project. That report should include, on the one hand, the functional (hydraulic and mechanical) diagnosis of the machine and the suggested improvements and, on the other hand, the results of the proposal validation tests.
2. Describing the concept of the new flushing machine prototype stemming from the machine being studied.

### Analysis of the hydraulic functioning of an existing machine

That feasibility study aims at investigating as comprehensively as possible the hydraulic functioning of a flushing machine. It includes a review of literature dealing with the past history of the machine and its improvements, together with the observation of the machine at work. The results are the basic data for an in situ measurement campaign in order to quantify the mechanical (machine weight and dimensions) and hydraulic (draught, thrust, sediment profile, advance speed) functioning parameters of the unit. A relevant unit still had to be selected for the study.

### Selection of an existing flushing machine

One machine seemed to be quite suitable for that upgrading study, namely the twin-ball car (see Figure 2). Though only one such machine does exist, it was selected because, in the sewermen's opinion, it was the most efficient one among the fleet of flushing units. Thus, a priori, it exhibited the features of an empirically improved unit having reached a good level of achievement. The efficiency of the twin-ball car was even coupled with a hazardous nature, since the car could hardly be controlled upon heavy flows in the interceptor. The twin-ball car can roll like a gate car, but unlike the latter, it travels along interceptors that are normally flushed by a gate boat.

The flushing tool is characterised in that it is not a gate, but it comprises two balls, each of them being housed in a trough arranged under the centre case. The latter is carried by a four-wheel mounted movable chassis. The balls and the case span the cunette, and water flowing under gravity beneath the case breaks through the dam as built up by the car. The jet flushes the sediment away downstream and re-suspends it.

### History of the twin-ball car

The design of the twin-ball car is historically related to atypical considerations. That unit does not result from changes in gate machines (either boats or cars), it was developed through watching ball flushing. The initial experimental ball flushing operations were conducted in the RAPP free surface interceptor on November 12–13, 1898, and then were repeated in the Bosquet interceptor on February 21–25, 1899.

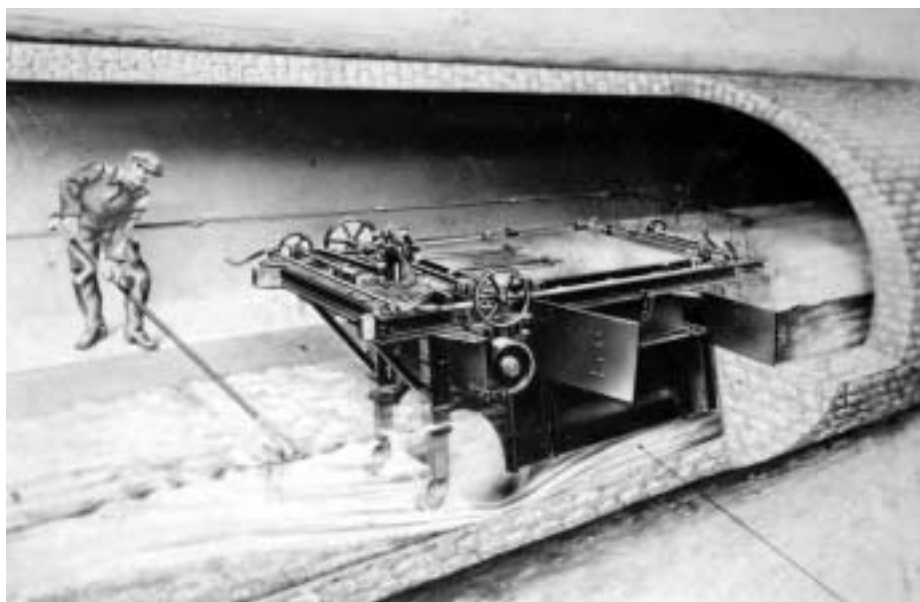

Figure 2 The twin-ball car at work

Design tracings and many more less elaborate sketches authenticate the existence of a project, but there is no evidence of any field test.

A drawing on the scale 1 to 20, dated January 1926, shows a twin-ball car that looks like the current machine; it was powered from flushing of the BIEVRE interceptor. No document tells whether that machine was ever constructed or commissioned.

The drawings of the machine used in the Bosquet interceptor were made in the late 50s. In the sewermen's opinion, these drawings show the second twin-ball car that was used in the Bosquet interceptor. The machine currently in use would be the third ever constructed unit. Upon its construction, it was slightly changed in relation to the earlier version (modification of the spade drawing, deletion of rollers from the balls, etc.).

#### **Functional analysis of the twin-ball car and its components**

The twin-ball car designer attempted to reconstitute a ball flushing in a pipe. A case was devised for holding two balls. The case bottom delineates two pipes together with the sewer cunette. Due to the vertical mobility of the case, the ball level can be adjusted and the jet flow rate can be controlled. The case should be carried by as stable a chassis as possible for reliably adjusting the position of the ball. A rolling chassis is then to be designed, instead of a floating one. The case is provided for longitudinally guiding the unit between the side-walls of the interceptor footways. A clearance and rollers that are fitted onto the case assist the machine in moving by sliding between the footway side walls.

From the drawings in the record file, it becomes obvious that the designer endeavoured to retain the ball beneath the machine. He first imagined to wrap the ball in a spherical metal cap, but that solution was quite soon superseded by the spade. The tracings and sketches suggest that the spade was intended for bearing on the sediment, not for digging into it. There is no evidence supporting the assumption that the spade would keep the machine optimally off the sediment.

Seemingly, the designer was convinced that the balls could turn round on themselves, and therefore he fitted rollers onto the ball car. The record file does not contain any comment about the way the ball car is to be handled. It can then reasonably be assumed that the twin-ball car was designed for continuously advancing behind the grit mound.

#### **Principle of operation of the machine**

The twin-ball car is operated through both swelling of the upstream water body and constriction of the water stream at the balls. According to that principle, the twin-ball car turns some potential energy into kinetic energy. The dam built up by the machine in the interceptor raises the water level ahead of the unit and gives the water stream a specific energy in which the potential energy prevails. The nozzle forces water to gain speed in order to pass the car. Immediately behind the machine, the specific energy of the water stream consists to a large extent of kinetic energy that sets the stream ability to wash the sediment away.

#### **Operation energy balance**

The twin-ball car gets an end thrust that ranges from 10,000 N to 18,000 N with flow rates fluctuating from 1.5 to 1.8 cu.m/s. The machine, however, proceeds slowly and often jerkily (from less than one metre an hour to sometimes nearly 30 m/hr). Consequently, the loads applied to the machine consume little power (some 10 watts). The head losses occurring beneath the car consume about 15% power within the water stream upstream from the machine (29 kW). Some 24.5 kW remain for flushing the grit away.

#### **Study of the existing machine through physical and numerical models**

This second step of the study aims at extending and going deeper into the investigations

of the earlier step. The procedure is based upon the joint use of a physical model and a numerical model that simulate flows around the machine both three-dimensionally and in a steady flow regime.

The flushing process is to be reconstituted in laboratory conditions using the measurements made for calibrating the model; in addition, data are to be collected through the numerical computation about the flows and the hydrodynamically-induced stresses that cannot be made available through in situ or laboratory measurements.

The functional and hydraulic diagnosis made from the field measurements and laboratory experiments makes it possible to contemplate possible improvements of the existing machine. A new machine concept was worked out from a global review of these studies; it was embodied in a physical model that will be tested in the same conditions as the physical model of the twin-ball car.

#### Description of the physical model

The physical model (1:5 geometric scale, Froude similarity) was prepared and implemented at the Lisbon national Laboratory of Civil engineering (LNEC) (see Figure 3). The LNEC was by the side of SAFEGE Ingénieurs Conseils in the group of designers with which a study contract was entered into by the SIAAP. This model makes it possible to reconstitute the flow conditions in the BIEVRE interceptor, as well as the present and future flushing units.

The 15 metre long small-scale model of the BIEVRE interceptor has Perspex walls for watching both flow and behaviour of immersed items (see Figure 4). It is a mobile bottom type model, since the grit mound representing the sediment partly occupies the assembly and moves in the model.

The grit used for modelling is non-cohesive, the friction and the shear stresses are not reproduced. The volume of the mound that is reconstituted for each test is equivalent to 50 cu.m of sediment. The conditions achieved this way provide reliable data about the behaviour of the existing car in front of the sediment mound. These conditions are ideal for flushing (low cohesion, no heavy items).

As regards the twin-ball car model, only those elements of the prototype which have major effects on the physical process to be reproduced (measurable variable) are strictly true to scale. Furthermore, the components should be able to withstand the loads applied to them during the tests. In addition, the position of the centre of gravity and the total mass of the twin-ball car model have been corrected after the construction in order to observe the



**Figure 3** Physical model of the twin-ball car



**Figure 4** Physical model of the BIEVRE interceptor

similarity with the prototype. The solid friction that is inherent to the machine has been reproduced by means of a ball being dragged along by the model.

The distance from the machine to the mound illustrates the resistance exerted by the mound on the advance of the machine. That resistance could be reproduced, on the one hand, by fitting disks onto the spades ahead of the unit, their positions being set for each simulated flow rate, and, on the other hand, by selecting a grit grain size that is slightly larger (4.85 mm) than the median diameter of the actual sediment (0–4 mm), which is more constraining for the model.

The physical model corresponding to the concept of the new flushing unit was constructed in the same spirit, in the perspective of its being transposed into an operational unit.

#### Description of the numerical model

The FIDAP computation code was used during the study. This software implements a finite element computation procedure: the domain occupied by the flow is divided into a number of simple-shaped regions that are referred to as finite elements. Each element is identified through the positions of so-called nodes or nodal points, which are points in space. The computation aims at solving, at each such node, the partial derivative equation of fluid mechanics that describe the flow. FIDAP uses the Navier-Stokes equations coupled with a turbulence model to be selected among a set of models available in the software.

The actions of the couple of balls could be evidenced through the results of the numerical computation (see Figures 5 and 6). It was found that the nozzle encompassing the jet path generates three parallel jets. The water stream behind the twin-ball car does not have an even thickness widthwise and the flow rate is not uniform over the whole cross sectional area of the jet.

Thus, the grit ridge as observed by the sewer men, which gathers as the pipe is axially flushed, results from the configuration of the jet passing between the two balls. Thus, the flushing results from three parallel, submerged and substantially round-sectioned jets. Therefore, the sediment is washed away by three localised impacts and the least active areas are located under the spades, in front of the balls.

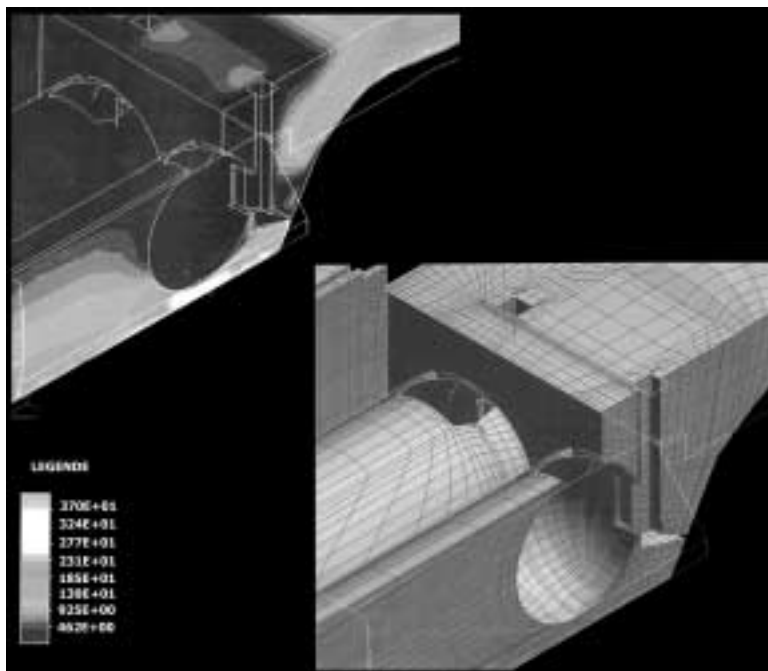

**Figure 5** Flow pattern around the balls

**Figure 6** Grid of the 3D numerical model

If any heavy item or residual sediment lens occurs in that place, the ball may bump against the obstacle, since the jet will not have cleared it away.

There is no torque with respect to the longitudinal and vertical axes. The balls will then not tend to rotate about these axes. On the other hand, the cross moment is by far from being negligible (from 210 to 360 N.m depending on the cases). In the absence of any friction, the ball, driven by the flow, would rotate counterclockwise.

#### Assessment of advantages and drawbacks of the twin-ball car

The present machine has not changed very much since its creation. The report on the machine origins and developments goes against the sewer men's oral tradition according to which the twin-ball car had achieved a suitable efficiency after many adaptations imposed by the flushing practice. The unit, however, is made reliable due to the simple operation concept being used.

Its effectiveness only depends on the water flow rate in the interceptor. The car takes power from the water flow and needs neither an external power supply nor an above-ground facility. The unit can only stop for three reasons, namely too low a flow rate, an obstacle, too high a grit mound. The mechanical construction is simple and rugged, suited to the environment, there are few moving components. The movement forward is governed by the shifting of the grit mound, the distance from that mound and the machine remaining constant. The sewer man does not change the machine positioning. A brake is made unnecessary by that system.

The labour is quite familiar with the machine, but the operation is hardly controlled in case of a sudden water swelling. The machine must then be moored. A hindered flow constitutes a major hazard. For instance, the twin-ball car was driven by a flood downstream from the BOSQUET interceptor after breaking loose from its moorings.

The machine, being not very versatile, can only be used in the straight interceptors. It lacks manoeuvrability, the mechanical clearances are small and the unit can get jammed in

the interceptor. The twin-ball flushing system provides no improvement in relation to a conventional gate. It splits three submerged jets that are more round than flat, which act more locally on the grit than a single flat jet spanning the whole cunette. The spades are massive and disturb the flow. They are overdimensioned in respect to their specific purpose.

### Design concepts adopted for the new machine

Considering both advantages and drawbacks of the current machine, it was decided to keep to the concept of using hydraulic energy as a motive force source and for flushing the grit away.

The design was conducted in view of preparing a prototype, searching for features liable to be transposed to a full-scale machine (see Figure 7). Further, the latest improvements aim at increasing the flushing efficiency and the machine stability upon a flood.

The new unit is characterised by the following major items:

- automatic matching of the unit, through a float, to a wide range of flow rates particularly covering the changes of flow rates as recorded over a normal day. To that purpose, the new unit should adapt itself to the flow regime by creating and keeping a level difference between the front and the aft of the machine, so that it should only be moved forward by the flow impulse;
- improvement of the waste retaining capacity ahead of the machine so that they can more easily be moved away through the replacement of spades by a grid. The grid comprises a bow arranged at its base and vertical bars that connect the bow to the chassis for stiffness purposes;
- detection of a heavy flow rate (flood) by the unit for safety purposes;
- provision of automatically-operated water retaining components;
- provision of a removable chassis the wheels of which rest on the platforms; this includes a lateral guiding system through rollers engaging the cunette;
- development of a moving assy that can match the flow regime, comprising a stem, a float and a metal frame arranged to move about the aft hub axis. That frame is fitted between the stem and the float, its motion makes it possible to set the stem opening; the frame is provided with a gate actuated about a pivot pin;
- two sets of hinged fins fitted between the chassis and the footway to keep the water body upstream.

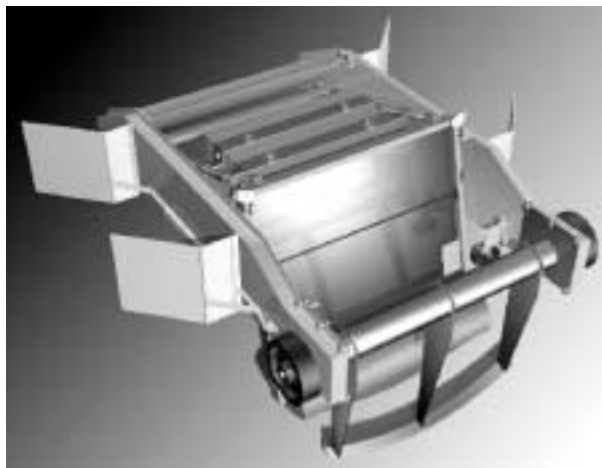

**Figure 7** Physical model of the new flushing unit on the scale 1:5



**Comparison of the respective performances of the twin-ball car and the new unit**

The respective performances of the two machines could be compared through the contractual programme tests that were conducted in the same conditions for the twin-ball car and the new unit (see Figure 8).

As soon as these machines are at work, they have similar advance speeds; the new unit speed, however, remains higher by 6–12% than the twin-ball car velocity. A better cleaning of the cunette is performed by the new unit which does not leave any sediment along the axis. Thus, it appears that the new machine has a more efficient cleaning action at similar advance speeds.

Upon a flood, the unit is set in a safety configuration: the fins tilt forwards and the centre gate swings. Nevertheless, it can carry on with its flushing work without any damage in the interceptor. That opens the way to a machine which, in a time, will be able to work autonomously in any weather conditions.

The newly adopted matching of the combined stem opening and float immersion works well at lower than 1.4 cu.m/s flow rates. That range covers about 80% of the flow rates that are recorded over a standard day, in normal conditions. It can then be expected that the new unit will work 4 times as long as the present unit in a 24 hour period of time. Thus, it would make it possible to flush another 550 m portion of interceptor, as compared with the twin-ball car.

**Conclusion**

Several inferences can be drawn from these tests. The will for innovation often leads one to hastily abandon allegedly obsolete practices and switch to new technologies. After initial setbacks, it frequently happens that they are inappropriate for the purpose. The requirements involved by sewerage techniques were already taken into account by the nineteenth century engineers who designed the operator’s tools. The flushing units which they developed have unquestionable environmental advantages: no external power, quietness, nuisance-free subsurface operation. The grit is only moved by the force of water in the system. This simple concept happens to be fairly disregarded and poorly quantified, but it is advocated by the oral tradition passed on by sewer men for generations, as well as by the empirical skill they have in the efficient use of the flushing units.

These findings resulted in another approach to the state of the art. Instead of rejecting the conventional mechanisation of flushing, we have tried to understand it through modern, effective investigation means. We have combined field measurement data, observation of

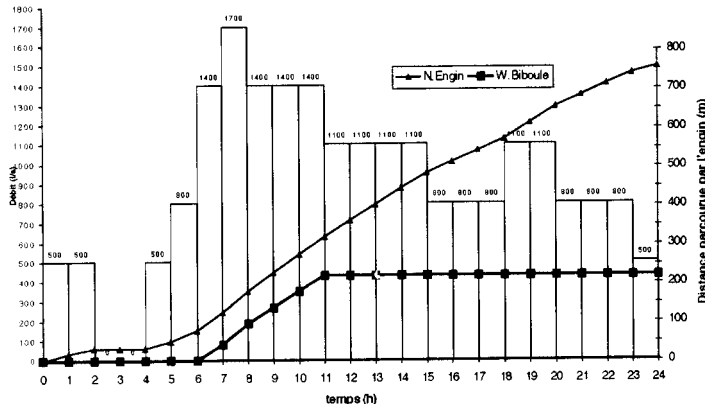

**Figure 8** Comparison of machine advances based upon average speeds as recorded in a steady flow regime over the range of rates being tested

sewermen practice, three-dimensional numerical modelling and physical modelling. This way, we succeeded in identifying, better understanding and better quantifying the hydraulic parameters involved in the flushing work carried out by the city of Paris fleet of machines. Among other things, the flushing processes could be finely reconstituted and studied through physical models.

How to upgrade the existing units was defined by the designers and the project manager who gave much thorough thought to the problems; exchanges of skill and views were some of the keys to the success. Since the jet discharged by the nozzle and cut by the balls is less efficient than the jet from a gate that conforms with the shape of the cunette, the balls were replaced by a gate the shape of which was optimised through measurement data and observations. The flushing gate adaptability to all the flow regimes makes it possible to achieve a substantially higher output. The new unit is then provided with a moving assy that matches its position to the flow conditions prevailing in the interceptor, so that the velocity of the sediment flushing jet is kept constant. Lastly, at the design stage, the new unit comprises mechanical devices which, upon a flood, collapse the items of equipment that hinder the flow. Such systems could be tested during the study of the new unit concept, so that their reliability could be evidenced. As regards methodology, the investigation tools of the first stage were used once again to switch from the knowledge of the existing machines to the future prospects and to validate the upgrading of the existing fleet.

The initial goals of the sewerage Department have been reached. The new method that was selected as an approach to the mechanised flushing of the interceptors made it possible to design a new unit which, starting from the existing machines, can be used in a more efficient, less hazardous and less difficult way by the sewermen, it being contemplated that flushing will take place autonomously later on. This project is only an initial step. The second one, consisting in designing an operational prototype, is in full progress, since the construction of the latter is under way. The first tests are scheduled in the MARCEAU interceptor by the end of the year 2000.