

Neuro-fuzzy modeling for level prediction for the navigation sector on the Magdalena River (Colombia)

Nelson Fernández, William Jaimés and Edmary Altamiranda

ABSTRACT

The variations associated with level changes and the state of the channel in the Magdalena River in Colombia (South America) frequently affect the navigation possibilities for boats and ferries, which cause high costs for their users. For this reason, this work presents a bio-inspired model to support the decision-making concerning the navigation using a neuro-fuzzy approach developed in previous works with a novel application. Considering the average daily levels of the river registered by the limnigraphical stations from the Colombian Institute for Hydrological, Meteorology and Environmental Studies (IDEAM), during the time period between 1998 and 2003 for the Puerto Salgar, Puerto Berrio, El Banco and Calamar locations, it was possible to design and establish a neuro-fuzzy hydrological model to predict with great precision the level of water in the river for the route of navigation, allowing the appropriate decision-making for Magdalena River operators to pre-determine the weight of shipment for any boat or ferry on their route. The developed model showed better performance for the forecasting than the previously established deterministic models for this specific application.

Key words | hydrologic prognostic, intelligence computation, level river prediction, river navigation

Nelson Fernández
William Jaimés
Centro de Investigaciones en Hidroinformática,
Universidad de Pamplona,
Km 1 vía Bucaramanga,
Pamplona,
Colombia
Tel.: +577 568 5303X198
Fax: +577 568 2750

Edmary Altamiranda (corresponding author)
VetcoGray a GE Oil & Gas Business,
Subsea Control Systems Department,
Sothammergeilen 1, Bygg 10,
Dusavik-Stavanger NO-4084,
Norway
Tel.: +47 5163 4978
Fax: +47 5163 4401
E-mail: edmary.altamiranda@ge.com

INTRODUCTION

Hydrological forecasting for the Magdalena River allows delivering sufficient information to the users stating the probability (quantitative or qualitative) of the characteristic conditions for the superficial or underground waters (water levels, water flow, water volume of sediments, water quality, etc). This information can support decision-making for the navigation sector in order to obtain the maximum benefits or to minimize the losses, representing adversity for the economic development, social well-being and environmental balance for the flow of products on the Magdalena River.

According to the experience of the Colombian Institute of Hydrology, Meteorology and Environmental Studies (IDEAM), there was an increasing need for hydrological forecasting in order to orient the decisions made by users of different areas on the river, such as: (1) short term

programming of water utilization; use of water level forecasting to generate the best utilization strategy in situations of water crisis for the hydro-energy sectors, fluvial navigation, farming and water supply for populations; (2) prevention of disasters (floods, shortage of water supply and crop losses) due to water excess, rises, overflows, low levels and extreme low levels and (3) prevention of water pollution; water dynamics and quality variables' information in certain sections of the river, which can support decision-making to avoid water pollution affecting the species or ecosystems exposed.

Conventionally, the forecasting of water levels has been obtained using deterministic or stochastic models, considering mathematical and physical principles that define the hydrological process dynamics. Deterministic models can be grouped as empirical or conceptual and we treat the

hydrological processes in a phenomenological way; they are also based on fundamental flow equations to simulate actual processes from historical streamflow data, as well as data on rainfall, infiltration, evapotranspiration, etc (Croton & Barry 2001). On the other hand, the stochastic modeling approach is used to generate long hypothetical sequences of discharges based on the statistical and probability characteristics of the historic records. Stochastic models can exhibit linear and nonlinear structure (Ochoa-Rivera 2008). Among linear models, the auto-regressive models (AR), moving average models (MA), auto-regressive moving average models (ARMA) and disaggregation models have been used. Among the non-linear models, the fractional Gaussian noise models (FGN), the broken line models (BL) and the periodic auto-regressive models (PAR) have been used for hydrological applications. For river flow forecasting, the stochastic models that have been most widely used belong to the class of ARIMA (Auto-Regressive Integrated Moving Average) models proposed by Box & Jenkins (1976) (e.g. Mujumdar & Kumar 1990).

Deterministic modeling applications have also been used for streamflow forecasting including nonlinear deterministic modeling in river flow (Sivakumar 2006) and nonparametric streamflow simulation by wavelet or Fourier analysis (Bayazit *et al.* 2001). Stochastic modeling applications can be found in National Weather Service River Forecast System (NWSRFS) studies, which are based on a probabilistic model (Day 1985), the Soil Moisture Accounting and Routing (SMAR) model, which is a conceptual type linear model of rainfall–runoff (Kachroo 1992), probabilistic models for forecasts in operational hydrology (Croley 2000); statistical modeling and its validation to mimic real flow and inundation patterns at the catchment, reach and waterbody scaled (Costelloe *et al.* 2003), the use of the K -nearest-neighbor resample designed for the use of synthetic data through an example with daily rainfall (Mehrotra & Sharma 2006) and the use of a partial least-squares regression (PLSR) technique for a long lead-time streamflow forecast model (Tootle *et al.* 2007). These models can exhibit linear or nonlinear characteristics with concentrated or distributed parameters among other features (Enfield *et al.* 2005; Kanso *et al.* 2005; Michael *et al.* 2005; Ye *et al.* 2005).

It is well known that accuracy in forecasting is a difficult task, in terms of prediction, due to the high degree of nonlinearity, uncertainty and time-variant behavior in hydrological dynamics (Li & Li 2000; Chang & Chang 2006). Recently, significant attention has been directed towards the modeling of hydrosystems using non-conventional techniques with approximation and generalization capabilities (Oh & Pedrycz 2006; Salski & Holsten 2006). Together with the evolution of computational intelligence, the testing and evaluation of bio-inspired techniques, like Artificial Neural Networks (ANN) for hydrological forecasts, have expanded and enriched the modeling field and, at the same time, they have proved to be a suitable alternative with substantial advantages with respect to conventional models (Wong 1991; Minnes & Hall 1996; Wedding & Cios 1996; ASCE Task Committee 2000a,b; Faraway & Chatfield 1998; Ni & Xue 2003; Cigizoglu & Kisi 2005, 2006; Ondimu & Murase 2007).

ANN are computational models that intend to replicate the brain neural processing. These data-driven techniques have been successfully applied for modeling of complex and nonlinear dynamic systems including hydrological systems to approach problems related to the prediction and forecasting of hydrologic variables. Multi-Layer Perceptron (MLP) and Recurrent Networks (RNN) have gained considerable attention for nonlinear systems modeling applications. The MLP provides a nonlinear static map between inputs and outputs of ANN (Beale & Jackson 1990), and several applications for the prediction of hydrologic variables using input–output nonlinear identification can be found (Gopakumar *et al.* 2007). The RNN have also gained popularity as an emerging dynamic neural network variant which can perform temporal processing using feedback loops that carry information from the previous processing steps into the current processing steps. (Pan & Wang 2004). In this context, neural networks have become popular in rainfall and runoff modeling (e.g. Jain & Indurthy 2003; Rajurkar *et al.* 2004), prediction of daily streamflow (Birikundavyi *et al.* 2002; Cigizoglu 2003), prediction of river discharge (Imrie *et al.* 2000), prediction of river stage (Thirumalaiah & Deo 1998), real-time prediction of catchment flow (Aqil *et al.* 2007), modeling rating curve

(Sudheer & Jain 2003) and for daily suspended sediment forecasting (Partal & Cigizoglu 2008), among other examples.

Besides the applicability of MLP ANN for the modeling of daily river flows, the Self-Organization Maps (SOMs), an unsupervised learning technique, have been used for modeling the exploration of rainfall and discharge patterns in humid tropical river basins for the monsoon period are carried out by Gopakumar *et al.* (2007). In that study, SOMs are used for exploration of hydrologic data and to identify the mutually dependent features characterizing the hydro-logic system of the basin in space and time, then with the knowledge derived from the SOM analysis the performance of the developed river flow model is improved.

Fuzzy Logic, originally proposed by Zadeh (1965), has also been used with good results in hydrological modeling, due to their potential of dealing with uncertainties, providing linguistic representation of the uncertain expressions associated with the system under study. Fuzzy logic has been successfully applied in modeling of hydrological processes such as rainfall forecasting (Yu & Chen 2000; Hundedcha *et al.* 2001; Xiong *et al.* 2001); reservoir operation (Russell & Campbell 1996); design of an expert system to determine stream water quality classification in Korea (Lee *et al.* 1997); in the development of a tool for assessing sustainability of stormwater management (Cobiac & Jansons 2005); and in the estimation of runoff and runoff coefficient (Şen & Altunkaynak 2005) among others. In general, fuzzy logic approaches have been applied in the estimation of water resources for more than a decade (Keskin *et al.* 2007).

The integration of neural networks and fuzzy logic has converged into the evolution of hybrid tools as Neuro-Fuzzy Systems or Adaptive Neuro-Fuzzy Inference systems (ANFIS). ANFIS has the potential to capture the benefits of both neural networks and fuzzy logic techniques in a single framework and can be employed to handle uncertainties in the systems conditions (Mehta & Jain 2008). Recently, in hydrological modeling studies, ANFIS has been demonstrating its potential in streamflow prediction (Aqil *et al.* 2007); modelling the complex turbulent fluxes across strong shear layers (Hankin *et al.* 2001); short-term water level prediction (Bazartseren *et al.* 2003); groundwater vulnerability prediction (Dixon 2005);

flood forecasting (Chen *et al.* 2006); daily pan-evaporation modeling (Kisi 2006); and river flow estimation and time-series modeling (Firat & Güngör 2007, 2008).

In the above context, this paper presents a novel ANFIS application for river level forecasting, based on historical time series, applied to the Magdalena River in Colombia for navigation purposes. This Neuro-Fuzzy Model (NMF) allows navigators to know the future river levels based on past river level values, with a relatively small margin of error. This allows better decision-making for the navigation sector applicable to cargo carriers and ships.

The neuro-fuzzy system applied in this paper is based on the approach presented in Altamiranda & Colina (2002). This approach differs from typical ANFIS in the properties for modeling on line complex nonlinear systems due to the dynamic features incorporated by recurrent connections and the variant time learning algorithm. Typical ANFIS systems are built in a feedforward structure and, in some cases, conformed by multiple layers. The proposed system in Altamiranda & Colina (2002) is a variant time recurrent single-layer system where global minimum error can be guaranteed. However, for the water level application presented in this paper the approach proposed by Altamiranda & Colina (2002) was applied in a different way. A static version of the algorithm was used for offline training of a neuro-fuzzy system to conform with the river water level model structure. The recurrent connections concept was applied only for the prediction structure, allowing us to obtain a prediction horizon of 10 days. The recurrent structure for prediction allows us to monitor the efficiency of the generated outputs within the prediction horizon and allow for updating the model in time when it is required, which makes the model valid in time. With conventional feedforward structures, if deviations are detected after some time the model has been generated, offline training, with numerous data and iterations, is needed each time the model needs to be updated.

HYDROLOGICAL MODELING BACKGROUND IN THE MAGDALENA RIVER

Since the 1970s, the Colombian government has been committed to better knowledge and comprehension of the

Colombian hydrological and morphological regimes on its rivers and to find satisfactory solutions to the fluvial navigational problems. At that time, in the case of the Magdalena River, the Netherlands government recommended the prediction of water levels during the season of low water for cargo operators based on the reasoning done by experts, on the crossed distance and minimal available depth of the distance (Rivera & Zamudio 2006).

According to Rivera & Zamudio (2006), Dutch experts were studying the decrease of water levels in the Calamar locality on the Magdalena River and recommended the implementation of their hydrological model to the Colombian government. This model has the following expression:

$$R_{C_t} = R_{C_{t_0}} \exp \left[(-\alpha t) + R_{LV}^*(t - \Delta t_1) + \gamma R_G^*(t - \Delta t_2) \right] \quad (1)$$

where R_{C_t} : flows of Magdalena River in Calamar, future time; $R_{C_{t_0}}$: flows of Magdalena River in Calamar, present time; R_{LV}^* : relative discharge of Cauca River in Las Varas; R_G^* : relative discharge of Cauca River in Gamarra; α , γ , β : coefficients to be assessed from the rating curves; t : time (in days); Δt_1 , Δt_2 : transit time periods.

Using Equation (1) they proposed to calculate the discharge at the Calamar locality transforming the discharge into the water level at this station from the flow calibration curve. Unfortunately, the recommendations and conclusions to improve navigation on the Magdalena River were not applied by the state agencies and another model has not been developed since then.

Later, at the beginning of the 1990s, with the creation of IDEAM, there was a rebirth of the need to implement a better alert system for extreme hydrological events (floods and low level water) in this river. In 2000 IDEAM was already processing real-time data transmission of water levels for the locations Puerto Salgar, Puerto Berrío, El Banco and Calamar. At the same time the qualitative system of hydrological alert was improved. Every morning, information about rain dynamics from the last few days and the variable forecasts of rainfall, cloudiness, air temperature and humidity over the whole country were provided. These were calculated using foreign models (Rivera & Zamudio 2006).

This information and the water levels dynamics allowed the elaboration of certain qualitative projections on the

water level trends for the next few days. In this way, qualitative forecasts were possible.

By the end of 2002, IDEAM defined a model which simulates the level dynamics by daily averages during periods of low water levels for Calamar, El Banco and Puerto Berrío along with Puerto Salgar. The following dynamic model was considered (Rivera et al. 2004):

$$\frac{dH}{dt} = f(\tau, k\zeta, H) \quad (2)$$

where τ : a parameter that represents the inertial property of any system under the influence of some external factor; k : a parameter that represents other system properties and ζ : a parameter that represents the external factor that influences the system.

Expressing the function by the following equation:

$$f(\tau, k\zeta, H) = \gamma h, \quad \gamma = f(k, \tau). \quad (3)$$

The parameters γh represent the internal system properties and the inertial property. In this case one of the properties was represented as ($\gamma = 1$), obtained after the calibration process.

The model for simulating the water level dynamics then has the following expression:

$$\frac{dH}{dt} = \gamma h. \quad (4)$$

To apply this model to the selected locations, the equation was solved following the deterministic equations:

$$H_{i+1} = \Delta t \gamma h + H_i \quad (5)$$

$$\gamma = 1 \quad \Delta t = 1. \quad (6)$$

$$h = \pm \left| \frac{H_{i-1} + H_i}{\phi} \right| \quad (7)$$

where H_i : water level in the location of interest (in meters); the index “ i ” indicates that water level is from the day it was forecast; H_{i-1} : water level in the location of interest (in meters); the index “ $i - 1$ ” indicates that water level is from the day before it was forecast; H_{i+1} : water level in the location of interest (in meters); the index “ $i + 1$ ” indicates that water level is from the next day forecast and ϕ : parameter that indicates the relation between water levels.

The positive or negative sign of h depends on: (a) rain quantity at the basin of the Magdalena River, (b) the trend of the rain at the basin, which was obtained from the meteorological forecasts, (c) the trend of humidity at the basin and (d) the topography upstream from the sited location.

The model allows the prediction of the water level in terms of daily averages during the low water period, as well as minimum and maximum average levels during the day. The values of the daily average level are estimated by the expression

$$H = \frac{\sum_{j=1}^n H_j}{n} \quad (8)$$

where n : total quantity of water level values; H_j : daily water level and H : average water level.

Currently the above developed and validated deterministic model (DM) for the four locations (Puerto Salgar, Puerto Berrío, El Banco and Calamar) is applied every day by the environmental corporation in charge of the management of the Magdalena River – CORMAGDALENA.

DESIGN AND IMPLEMENTATION OF THE NEURO-FUZZY HYDROLOGIC MODEL (NFM)

The design of the proposed model is based on the neuro-fuzzy approach presented in Altamiranda & Colina (2002).

Neuro-fuzzy structure

The concept associated with this approach modifies the conventional neuron model which possesses constant synaptic weights followed by a nonlinear activation function. The neuro-fuzzy structure has nonlinear synapses characterized by sets of fuzzy IF–THEN rules with singleton weights as a consequence; recurrent connections are also included to provide dynamic properties to this model; These characteristics make this structure a good candidate for modeling of complex nonlinear systems.

The structure of the fuzzy neuron presented in Altamiranda & Colina (2002) is shown in Figure 1.

Providing a quadratic learning error, a single ordinary neuron model guarantees to find a global minimum.

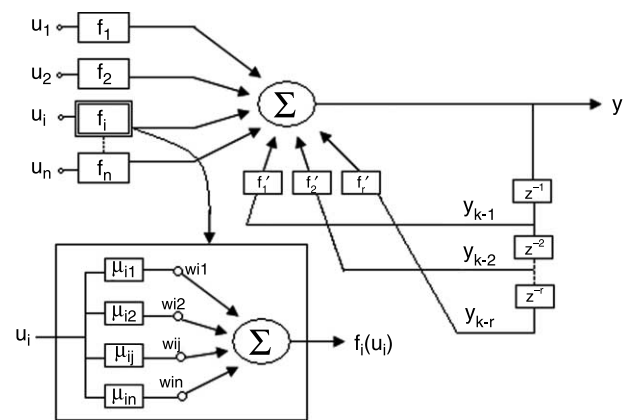

Figure 1 | Neuro-fuzzy structure.

The neuron output (9) and the learning error (10) are represented by

$$Y = \sum_{i=1}^m f_i(x_i) \quad (9)$$

$$E = \sum_{k=1}^p (y_k - y_k^d)^2 \quad (10)$$

where x_i is the input signal to the i th synapse, w_i the corresponding input weight, y_k the neuron output for the k th pattern, y_k^d is the desired output at the k th training pattern and p is the number of patterns.

Note from (9) and (10) that the error-weight space exhibits a parabolic function. In order to avoid the local minima problem, a fuzzy neuron, where many parameters can be embedded, can accomplish generalization by itself.

The characteristics of each synapse are represented by a nonlinear function f_i for feedforward connections and \tilde{f}_i for feedback connections. The feedback inputs correspond to dynamic delays of the neuron output. Aggregation of synaptic signals is achieved by an algebraic sum.

Thus the output of this fuzzy neuron can be represented by the following Equation (11):

$$Y = \sum_{j=1}^n f_j(u_j) + \sum_{r=1}^l \tilde{f}_r(y_{k-r}). \quad (11)$$

Note that the input space is $(x_1, \dots, x_m) = (u_1, \dots, u_n, y_{k-1}, \dots, y_{k-l})$, where $m = n + l$. The input space for x_i is divided into several fuzzy segments which are characterized by

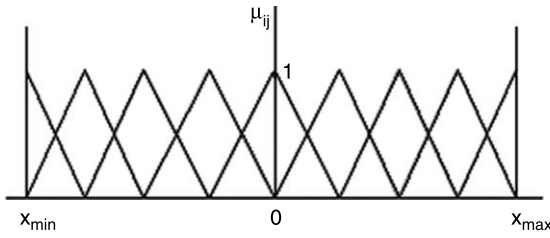

Figure 2 | Membership functions for nonlinear synapses.

membership functions $\mu_{i1}, \mu_{i2}, \dots, \mu_{iq}$ within the range between x_{\min} and x_{\max} , as shown in Figure 2.

The associated nonlinearities are determined by fuzzy IF-THEN rules and the k th fuzzy IF-THEN rule in the i th synapse output is obtained by fuzzy inference with defuzzification, represented by:

If input signal x_i is included in the fuzzy segment μ_{ik} then the synapse output is w_{ik} .

Compatibilities of the input signal x_i with the antecedents of these rules are obtained from the membership functions $\mu_{ik}, \mu_{i,k+1}$ at which the constants w_{ik} and $w_{i,k+1}$ as a consequence should be adopted.

A deterministic value of the synaptic output is obtained by the defuzzification, the so-called *center-of-gravity method*, defined by

$$f(x_i) = \frac{\sum_{j=1}^n \mu_{ij}(x_i) w_{ij}}{\sum_{j=1}^n \mu_{ij}(x_i)} = \frac{\mu_{ik}(x_i) w_{ik} + \mu_{i,k+1}(x_i) w_{i,k+1}}{\mu_{ik} + \mu_{i,k+1}}. \quad (12)$$

Since the membership functions are complementary (the summation of two neighboring membership functions is always unity), an input signal x_i activates only one or two rules simultaneously for each synapse. Thus, the output of the fuzzy neuron may be rewritten as:

$$f(x_i) = \mu_{ik}(x_i) w_{ik} + \mu_{i,k+1}(x_i) w_{i,k+1}. \quad (13)$$

This equation implies that only activated branches are effective for learning: therefore, only one or two weights corresponding to the activated branches are adjusted at the time.

Learning algorithm for the neuro-fuzzy structure

The learning algorithm used for this application is the static version of the algorithm presented in Altamiranda & Colina (2002), since the training is performed offline.

The general learning algorithm is defined in terms of a steepest descent method, where the change of weights is achieved for a set of input patterns p . The error index is given by the average squared error for p patterns in the following way:

$$E(k) = \frac{1}{2P} \sum_{q=1}^P (y_q(k) - y_q^d(k))^2 = \frac{1}{2P} \sum_{q=1}^P e_q^2(k) \quad (14)$$

where $y_q(k)$ is the output of the neuro-fuzzy structure, $y_q^d(k)$ is the desired output corresponding to the pattern q at time k and $e_q(k)$ is a learning error between the RFN and the desired output at time k . During the learning sessions, the updating rule for the weights is given by

$$w_{i,j}(k+1) = w_{i,j}(k) + \Delta w_{i,j}(k). \quad (15)$$

$$\Delta w_{i,j}(k) = -\alpha \frac{\partial E(k)}{\partial w_{i,j}(k)}. \quad (16)$$

The derivatives of the error index $E(k)$ with respect to the weights of the RFN are as follows:

$$\frac{\partial E(k)}{\partial w_{i,j}(k)} = \sum_{q=1}^P e_q(k) \frac{\partial y_q(k)}{\partial w_{i,j}(k)}. \quad (17)$$

The adjustment for weights $w_{i,j}$ in time k is given by

$$\Delta w_{i,j}(k) = -\alpha \sum_{q=1}^P \left[\frac{\partial y_q(k)}{\partial f_i(x_{q,i}(k))} \frac{\partial f_i(x_{q,i}(k))}{\partial w_{i,j}(k)} \right] \quad (18)$$

where $x_{q,i}(k)$ corresponds to the q th pattern of the i th input:

$$\Delta w_{i,j}(k) = -\alpha \sum_{q=1}^P (y_q(k) - y_q^d(k)) \mu_{i,j}(z_{q,i}(k)). \quad (19)$$

On the other hand, recurrent connections are adapted using the next updating rule:

$$\Delta \tilde{w}_{i,j}(k) = \Delta_1 \tilde{w}_{i,j}(k) + \Delta_2 \tilde{w}_{i,j}(k)$$

$$\Delta_1 \tilde{w}_{i,j}(k) = -\alpha \sum_{q=1}^P e_q(k) \tilde{\mu}_{r,j}(y_q(k-r)) \quad (20)$$

$$\Delta_w \tilde{w}_{i,j}(k) = -\alpha \sum_{q=1}^P e_q(k) \left[\frac{\partial y_q(k)}{\partial y_q(k-r)} \right] z_{q,i}^r(k)$$

where the $\mu_{i,j}$ and $\tilde{\mu}_{r,j}$ terms correspond to membership functions associated to weights $w_{i,j}(k)$ and $\tilde{w}_{r,j}(k)$, respectively, and

$$\frac{\partial y_q(k)}{\partial y_q(k-r)} = \tilde{w}_{r,j}(k) \dot{\mu}_{r,j}(y_q(k-r)) + \tilde{w}_{r,j+1}(k) \dot{\mu}_{r,j+1}(y_q(k-r)). \quad (21)$$

Let $z_q^r(k)$ be defined as

$$z_q^r = \frac{\partial y_q(k-r)}{\partial \tilde{w}_{r,j}(k)}. \quad (22)$$

In order to provide dynamic characteristics to the updating rule for recurrent connections, Equation (22) is determined through successive application of the chain rule. Without loss of generality, only first-order terms are considered and therefore $z_q^r(k)$ may be represented by the following first-order time-varying linear system:

$$z_q^r(k) = \frac{\partial y_q(k-r)}{\partial y_q(k-r-1)} z_q^r(k-1) + \frac{\partial y_q(k)}{\partial \tilde{w}_{r,j}(k)}.$$

$$z_q^r = \left[\tilde{w}_{r,j}(k-1) \dot{\mu}_{r,j}(y_q(k-r-1)) + \tilde{w}_{r,j+1}(k-1) \dot{\mu}_{r,j+1}(y_q(k-r-1)) \right] z_q^r(k-1) + \dot{\mu}_{r,j}(y_q(k-r)). \quad (23)$$

$$\Delta \tilde{w}_{r,j}^p(k) = -\alpha \sum_{q=1}^p e_q \left[\mu_{r,j}^v(e_q(k-r)) + \frac{\partial y_{vq}(k)}{\partial e_q(k-r)} \right] z_q^r(k). \quad (24)$$

This is the general algorithm for an RFN, where one or more dynamic delay(s) corresponding to the output term can be embedded as recurrent inputs.

Application of the neuro-fuzzy structure for modeling and prediction in the Magdalena River

Study area and input dataset

The data for the model synthesis was provided by the Colombian Institute for Hydrological, Meteorology and Environmental Studies (IDEAM) corresponding to average daily levels of the river registered by the limnigraphical stations in the Magdalena River (see Figure 3) at the



Figure 3 | Study area.

locations: Puerto Salgar (5°28'0; 168 msnm; tribute area: 74,410 km²), Puerto Berrío (6°30'0; 108 msnm; tribute area 56,905 km²), El Banco (9°0'0; 24 msnm; tribute area 161,292 km²) and Calamar (10°15'0; 8 msnm; tribute area 275,438 km²).

The statistical characteristics (i.e. mean and standard deviation; $X \pm S_x$, variation coefficient; C_{vx} , skewness coefficient; C_{sx} , curtosis; C_{ux} , maximum value; X_{Max} , minimum value; X_{Min} , confidence intervals 95%; $X_{95\%}$) for the total observed daily datasets in the four locations are given in Tables 1 and 2 for the training and testing data, respectively.

Neuro-fuzzy structure for level modeling in the Magdalena River

The neuro-fuzzy structure used for the river modeling only considers feedforward connections to synthesize a time series representation in days. The inputs correspond to the level of water during three consecutive days and the output corresponds to the day after. This is illustrated in Figure 4.

The original algorithm presented by Altamiranda & Colina (2002) is proposed for online training of both feedforward and recurrent connections, for online modeling

Table 1 | Statistical characteristics of water levels values (in meters) at the study area used as training data

Characteristic	Puerto Salgar	Puerto Berrio	El Banco	Calamar
N (d)	1,000	1,000	1,000	1,000
$X \pm S_x$	2.9331 ± 0.6304	4.1297 ± 0.4381	7.0147 ± 1.2458	6.4350 ± 1.5895
C_{vx}	21.150	10.60	17.76	24.702
C_{sx}	0.0428	0.5460	-1.1981	-1.5385
C_{ux}	-0.5959	-0.6035	1.7869	2.1823
X_{Max}	4.15	4.97	9.01	8.65
X_{Min}	1.49	3.46	3.58	2.1
$X_{95\%}$	2.900, 2.967	4.106, 4.153	6.949, 7.081	6.351, 6.519

applications where the variables to be estimated are always available online to adjust continuously the neuron synapses. For this case the data available correspond to historical data, therefore the training needs to be performed offline for the main feedforward connections in the modeling phase. The feedback connections are only used for the prediction phase.

Consequently, the fuzzy sets in the model associated with nonlinear synapses are triangular complementary functions and are shown in Figure 5.

The linguistic labels associated with the level functions are structured in nine complementary membership functions (three functions per each level representation: Low, Medium and High), as illustrated in Figure 5. Since the model is calculated using time series corresponding to the river level, the membership functions are the same for each input.

For x_i , $i = 1 - 3$, the membership functions can be detailed according to Figure 5 as follows:

Membership functions for low level characterization:

$$\begin{aligned}\mu_{i1} &= LL \\ \mu_{i2} &= LM \\ \mu_{i3} &= LH\end{aligned}\quad (25)$$

Membership functions for medium level characterization:

$$\begin{aligned}\mu_{i4} &= ML \\ \mu_{i5} &= MM \\ \mu_{i6} &= MH\end{aligned}\quad (26)$$

Membership functions for high level characterization:

$$\begin{aligned}\mu_{i7} &= HL \\ \mu_{i8} &= HM \\ \mu_{i9} &= HH\end{aligned}\quad (27)$$

Table 2 | Statistical characteristics of water levels values (in meters) at the study area used as testing data

Characteristic	Puerto Salgar	Puerto Berrio	El Banco	Calamar
N (d)	90	90	90	90
$X \pm S_x$	2.8091 ± 0.3592	3.8654 ± 0.4847	7.9809 ± 0.7571	6.9451 ± 0.4093
C_{vx}	12.84	12.67	10.56	5.81
C_{sx}	-0.0342	0.1591	-0.3743	0.0279
C_{ux}	-0.4415	-0.2128	-0.6750	-1.0366
X_{Max}	3.60	4.97	8.27	7.56
X_{Min}	2.03	2.91	5.49	6.21
$X_{95\%}$	2.778, 2.816	3.830, 3.882	7.068, 7.148	6.924, 6.966

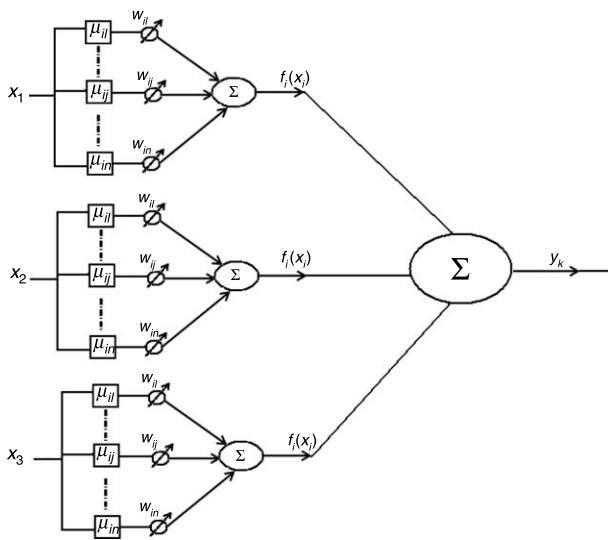

Figure 4 | Neuro-fuzzy structure for water level modeling on the Magdalena River. x_i corresponds to the river level in meters (m) at day “ i ”.

This determines nine segments for characterizing the inputs and therefore the rules can be defined as follows.

If input signal x_i (river level at day i) is included in the fuzzy segment μ_{ik} , then the synapse output that will be active at day i will be w_{ik} .

where $i = 1 - 3$; $k = 1 - 9$ and w_{ik} is calculated according to Equations (15–19).

It can be observed from Figure 5 that the nine fuzzy segments allow the fuzzy structure to have diversity on the branch activations according to the river sections. The lowest river level segment starts in 0 m and the highest level triangular segment ends in 8 m. The trapezoid segment at the end allows higher level values for flexibility and to give also possibilities of further updates to the model in the future. Any value above 8 m is considered *HH* with membership value “1”. The river sections have different

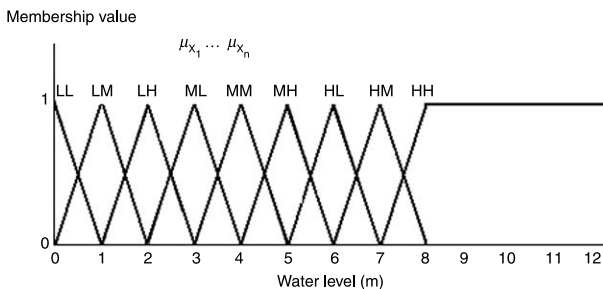

Figure 5 | Fuzzy sets for nonlinear synapses (L: Low, M: Medium, H: High levels).

minimum and maximum levels which are within these minimum and extended maximum values for the fuzzy segments. The selection of the fuzzy triangular sets in the proposed way, where each of them covers about 2 m within the maximum total range, together with the complementary property of the functions make possible a different activation of the neuron branches (segments) for each case, avoiding overtraining and better generalization features.

The training is achieved offline, with a learning rate $\alpha = 0.9$. Training patterns were chosen from a database corresponding to the river level during the time period between 1998 and 2003. The pattern window for the learning algorithm described in the previous section was defined as $p = 10$ patterns for each learning time instant.

Neuro-fuzzy structure for level forecasting in the Magdalena River

The adjusted nonlinear synapses during the offline training phase were used to achieve the prediction of the time series in a feedback structure with external initial conditions corresponding to the first three days of a 13 day validation pattern, see Figure 6. The prediction horizon considered for this application was 10 d.

This neuro-fuzzy structure illustrates the static model trained offline given by the feedforward connections and

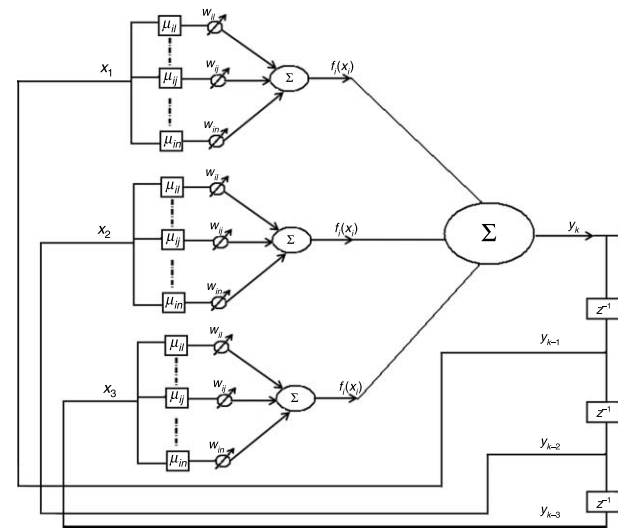

Figure 6 | Neuro-fuzzy structure for river water level forecasting, where x_1 represents the river level at day $(k - 1)$, x_2 the river level at day $(k - 2)$ and x_3 the river level at day $(k - 3)$. Y is the river level at day k .

the dynamic portion given by the feedback connections which have been incorporated to validate the prediction horizon. The first time the model is used for forecasting, initial conditions of the river level need to be provided for the first three days. For the extended prediction, the neuro-fuzzy structure will process the outputs generated in previous steps to produce the subsequent outputs within the prediction horizon. Initial conditions for the river level need to be updated with the historical data values, outside the prediction horizon.

Implementation of the hydrological neuro-fuzzy application for the Magdalena River

The application of neuro-fuzzy structures developed for water level prediction in the Magdalena River was implemented using Matlab 7.4 with a graphical user interface.

MODELING AND PREDICTION RESULTS

The model application results, shown as follows, are discussed based on the prediction carried out for levels observed in the Magdalena River at the locations of Puerto Salgar, Puerto Berrío, El Banco and Calamar in November 2000.

Additionally, in order to have a comparative reference for the model prediction ability, the neuro-fuzzy model (NMF) was run in parallel with the Deterministic Model (DM) proposed by Rivera *et al.* (2004), developed for IDEAM, which is currently applied for decision-making in the sector under study and which is available online at: <http://www.cormagdalena.gov.co>.

The graphs presented in Figure 7 illustrate the performance of both models, NFM (dotted line) and DM (dashed line), for prediction of daily water level at the four locations on the Magdalena River, in contrast with

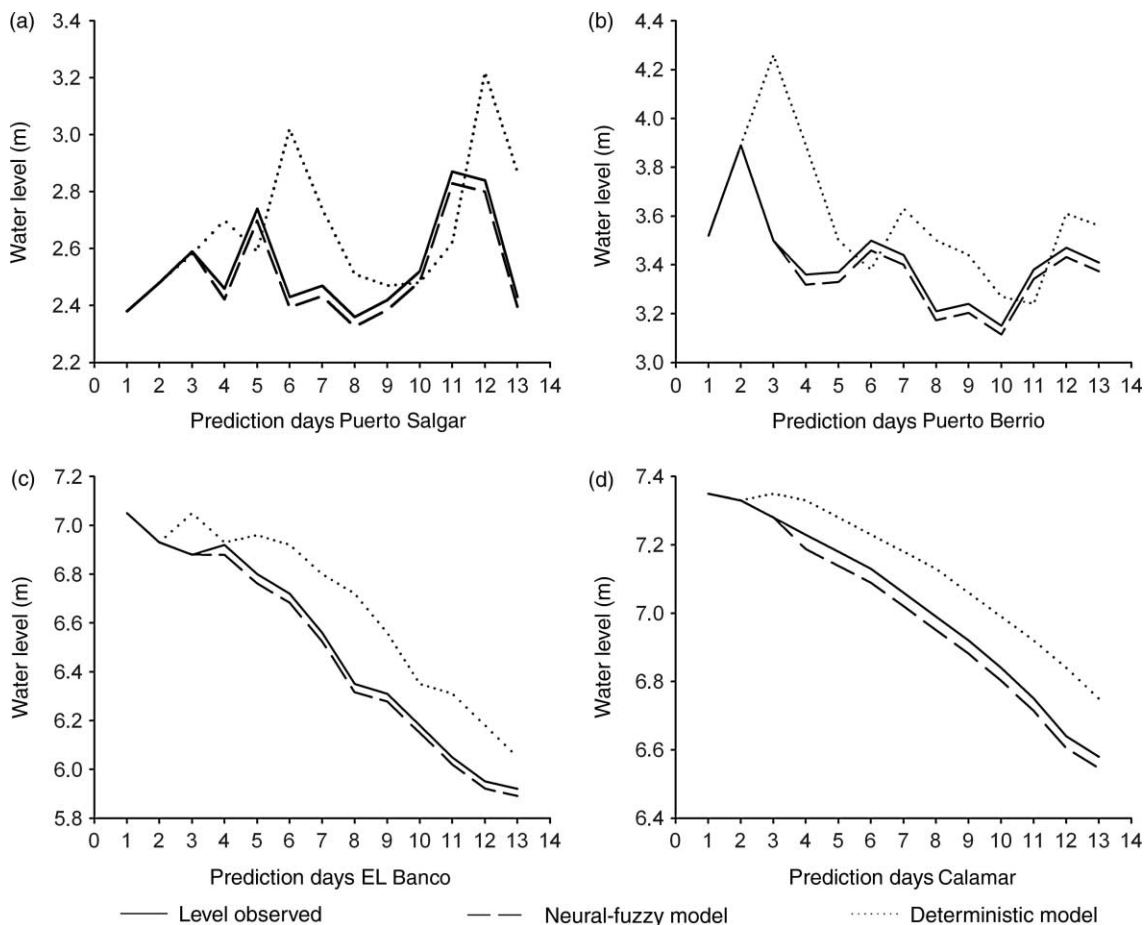

Figure 7 | Neuro-fuzzy and deterministic comparative forecasting for (a) Puerto Salgar, (b) Puerto Berrío, (c) El Banco and (d) Calamar.

the level observed (solid line). It is illustrated in these graphics that the NMF estimate follows the observed values better in all locations than does the DM. It can be observed especially at the first two stations, Puerto Salgar and Puerto Berrío (Figures 7(a, b)), where the behavior to be predicted showed a greater variability and the DM is further away from the real data. In spite of this related difficulty, the NFM showed greater accuracy. Thus, the general performance of NFM in comparison to the observed values was better than the DM, mainly due to the overestimation generated by the DM.

The above-mentioned situation is confirmed by the scatterplots shown in Figure 8 that show the measured values of water level and predicted values from NFM and DM. As can be observed from these scatter diagrams, the performance of NFM is more accurate than DM for all

cases. The NMF estimates follow more closely the observed values and they are quite near the fitted 45° line, which is the reference for a perfect fitting applicable for both NFM and DM models, indicating that the predicted and expected values are the same. This fact can also be established according to the performance and the adjustment estimators (Table 3): the correlation coefficient, the root mean squared error (RMSE) (Sudheer *et al.* 2002), the mean absolute error (MAE) and the goodness-of-fit measures of Gbench (Chang & Chang 2006) were calculated. In a comparative way, the best adjustment was obtained by the neuro-fuzzy model (NFM), rather than the deterministic model (DM). This could be confirmed with the implementation of performance criteria that are shown in Table 1. It is notable that NFM had more significant correlation coefficients ($p < 0.01$) for all cases, while the DM did not

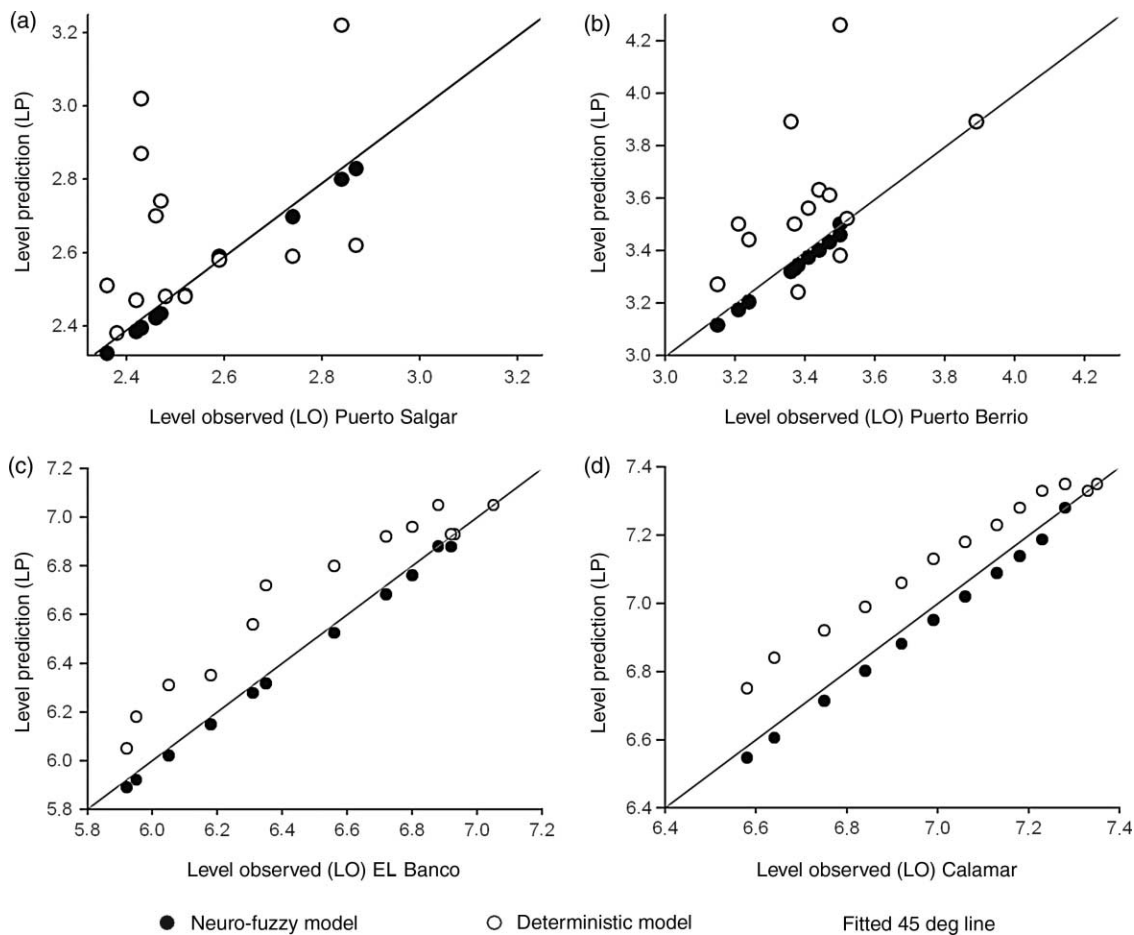

Figure 8 | Scatter diagrams of predicted vs observed from NMF and DM values for (a) Puerto Salgar, (b) Puerto Berrío, (c) El Banco and (d) Calamar.

Table 3 | Evaluation criteria of performance of the models

	Puerto Salgar		Puerto Berrio		El Banco		Calamar	
	NFM	DM	NFM	DM	NFM	DM	NFM	DM
R	0.9910	0.1210	0.9950	0.2450	0.9980	0.9340	0.9970	0.9840
RMSE	0.0377	0.3047	0.0386	0.2342	0.0324	0.2211	0.0387	0.1428
MAE	0.0376	0.1680	0.0385	0.1490	0.0339	0.2020	0.0386	0.1390
Gbench	0.0268	2.6205	0.0794	1.7402	0.0545	3.4928	0.1242	3.9746
AA	1.47	10.01	1.15	6.02	0.53	3.20	0.56	2.02

NFM: neuro-fuzzy model; DM: deterministic model (Rivera et al. 2004). For all cases NFM presents the best performance (values in bold).

reach adequate correlations for the predictions of Puerto Salgar and Puerto Berrio ($p > 0.05$), as it did for El Banco and Calamar. This fact was confirmed by the calculation of other performance criteria for the models, such as RMSE, which evaluated the residuals and which shows that the DM has significant errors since for this indicator

the greater errors are more important than the smaller ones. With regards to the MAE, the NFM shows average absolute errors that are lower than the DM at all the prediction sites (lower than 0.04). From Gbench it was observed that the behavior of the NFM, coming close to zero, can be classified within the *good-fit category* (Chang & Chang 2006).

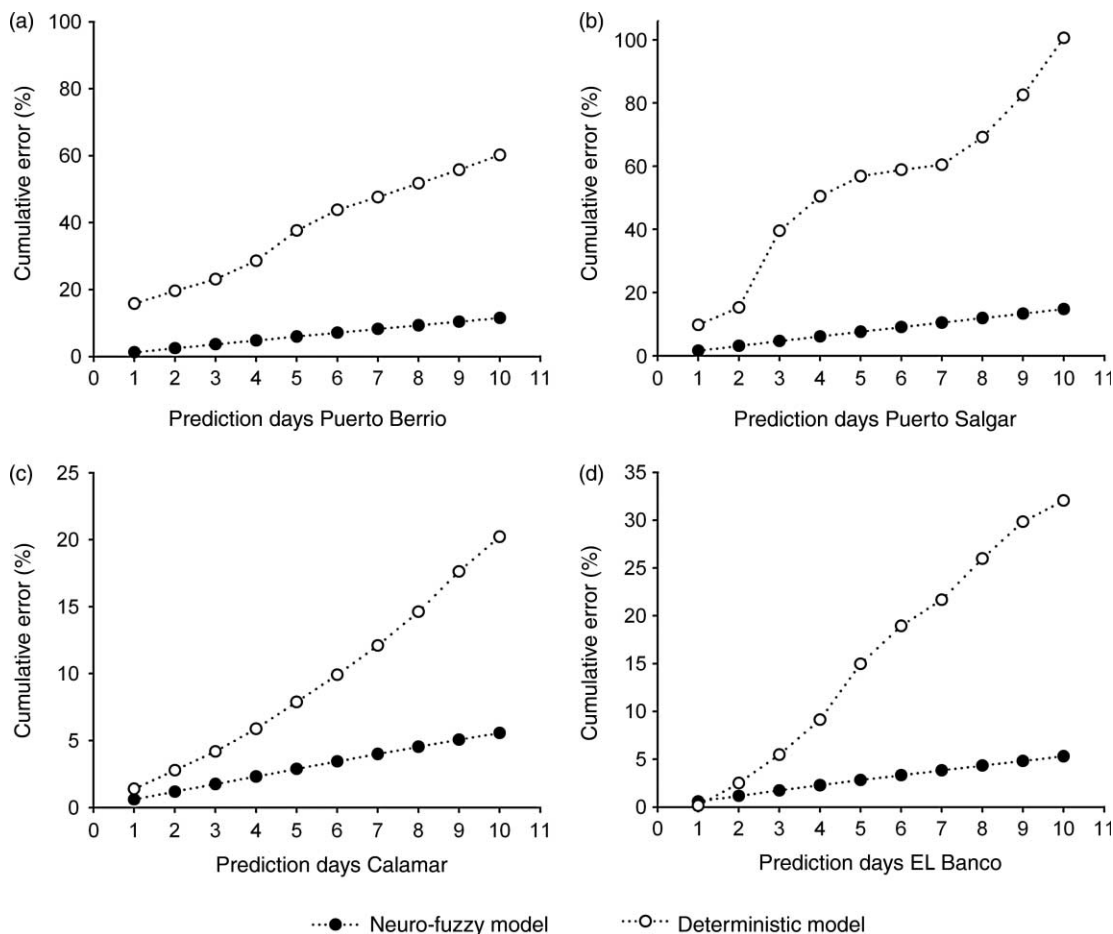
**Figure 9** | Cumulative percentage errors from the NFM and DM models.

Finally, in order to test the robustness of each developed model, the average absolute error evaluation criterion (AARE), which gives performance in terms of prediction level, was used. Thus, the calculated values for AARE show that the average of the NFM was lower than 1.5%, while the DM showed an average error margin of up to 10%. Perhaps the most important point to highlight in this analysis is the consistency shown by the NFM and its minimal variation in the validations made throughout the stations studied.

The importance of the error margin is made more evident when observing the progression of the percentage accumulative errors made on those forecasted days; results are shown in Figure 9. It is possible to notice that the DM reaches accumulated percentages closer to 100 for the stations all along the Magdalena River as follows: Puerto Salgar–100.6%; Puerto Berrio–53.3%; el Banco–32.03% and Calamar–40.4%. The NFM remained under the 14% mark in the case of the highest accumulated error as happened at Puerto Salgar. On the basis of the previous adjustment estimators, it can be seen that the NMF was more efficient in the prediction water levels for the Magdalena River.

CONCLUSIONS

In this study, the comparative applicability and capability of a neuro-fuzzy model developed for the Magdalena River water level modeling and prediction against a deterministic model was investigated through the use of datasets from four locations. The results obtained suggest that the NMF method is superior to the DM method in the modeling and forecasting of the river level. The better performance of the NFM was confirmed in terms of the statistics for the prediction error; even more when it is compared with the deterministic model which presents a higher prediction error. This fact can be emphasized by observing that the deterministic model predicts the water level one day ahead, based on two previous days' information. On the other hand, the NFM shows more consistent results over a ten-day period, based on three previous days' data. Therefore, it can be concluded that the NFM has achieved a longer prediction horizon (10 days) compared to the deterministic models used before.

In addition the results of the NMF demonstrate that it can be successfully applied to establish the water level in the Magdalena River. This model constitutes a powerful tool which has proved to be very valuable for the prediction of levels of water at Magdalena River stations, supporting the decision-making for Magdalena River operators to pre-determine the weight of shipment for any boat or ferry on their voyage.

ACKNOWLEDGEMENTS

The authors are grateful to the University of Pamplona and Dr. Hebert Rivera at IDEAM that supported the research. The authors are also very grateful to the anonymous reviewers, especially with reviewer 1, for their helpful comments and hints. Besides the authors, the following people took part in the project: Helen Cater, Nadine Kieff, Carmen Rosa Jaimes, Claudia Rico, Nidia Y. Florez, Gabriel Ramos, Eliezer Colina, Edgar Andrei Pérez (Paul), Edwin Gauta, Luis Carvajal and Diego Lizcano.

REFERENCES

- Altamiranda, E. & Colina, E. 2002 A recurrent fuzzy neuron for on line modeling of nonlinear systems. In: *Proceedings of 15th Triennial IFAC World Conference, Barcelona, Spain*.
- Aqil, M., Kita, I., Yano, A. & Nishiyama, S. 2007 Neural networks for real time catchment flow modeling and prediction. *Water Res. Manage.* **21**, 1781–1796.
- ASCE Task Committee 2000a Artificial neural networks in hydrology–I: preliminary concepts. *ASCE J. Hydrol. Eng.* **5** (2), 115–123.
- ASCE Task Committee 2000b Artificial neural networks in hydrology–II: hydrologic applications. *ASCE J. Hydrol. Eng.* **5** (2), 124–137.
- Bayazit, M., Onoz, B. & Aksoy, H. 2001 Nonparametric streamflow simulation by wavelet or Fourier analysis. *Hydrol. Sci. J.* **46** (4), 625–634.
- Bazartseren, B., Hildebrandt, G. & Holz, K. P. 2003 Short-term water level prediction using neural networks and neuro-fuzzy approach. *Neurocomputing* **55**, 439–450.
- Beale, R. & Jackson, T. 1990 *Neural Computing: An Introduction*. IOP Publishing, Bristol.
- Birikundavyi, S., Labib, R., Trung, H. & Rousselle, J. 2002 Performance of neural networks in daily streamflow forecasting. *ASCE J. Hydrol. Eng.* **7** (5), 392–398.
- Box, G. E. P. & Jenkins, G. M. 1976 *Time Series Analysis: Forecasting and Control*. Holden-Day, San Francisco, CA.

- Chang, F. J. & Chang, Y. T. 2006 Adaptive neuro-fuzzy inference system for prediction of water level in reservoir. *Adv. Water Res.* **29**, 1–10.
- Chen, S. H., Lin, Y. H., Chang, L. C. & Chang, F. J. 2006 The strategy of building a flood forecast model by neuro-fuzzy network. *Hydrol. Process.* **20**, 1525–1540.
- Cigizoglu, H. 2003 Incorporation of ARMA models into flow forecasting by artificial neural networks. *Environmetrics* **14** (4), 417–427.
- Cigizoglu, H. K. & Kisi, O. 2005 Flow prediction by three back propagation techniques using k-fold partitioning of neural network training data. *Nord. Hydrol.* **36** (1), 49–64.
- Cigizoglu, H. K. & Kisi, O. 2006 Methods to improve the neural network performance in suspended sediment estimation. *J. Hydrol.* **317**, 221–238.
- Cobiac, L. & Jansons, K. 2005 A fuzzy method of assessing sustainability in stormwater planning. *Water Intelligence Online*. Available at: <http://www.iwaponline.com/wio/2005/03/wio200503007.htm>
- Costelloe, J. F., Puckridge, J. T., Reid, J. R., Pritchard, J., Hudson, P., Bailey, V. & Good, M. 2003 Environmental flow requirements in arid zone rivers—a case study from the Lake Eyre Basin, central Australia. *Water Sci. Technol.* **48** (7), 65–72.
- Croley, T. E., II 2000 *Using Meteorology Probability Forecasts in Operational Hydrology*. ASCE Press, Reston, VA.
- Croton, J. T. & Barry, D. A. 2001 WEC-C: a distributed, deterministic catchment model—theory, formulation and testing. *Environ. Modell. Softw.* **16**, 583–599.
- Day, G. N. 1985 Extended streamflow forecasting using the NWSRFS. *J. Water Res. Plann. Manage.* **111** (2), 157–170.
- Dixon, B. 2005 Applicability of neuro-fuzzy techniques in predicting ground-water vulnerability: a GIS-based sensitivity analysis. *J. Hydrol.* **309**, 17–38.
- Enfield, C. G., Wood, A. L., Espinoza, F. P., Brooks, M. C., Annable, M. & Rao, P. S. 2005 Design of aquifer remediation systems: (1) describing hydraulic structure and NAPL architecture using tracers. *J. Contam. Hydrol.* **81** (1–4), 125–147.
- Faraway, J. & Chatfield, C. 1998 Time series forecasting with neural networks: a comparative study using the airline data. *J. Royal Stat. Soc.: Series C* **47** (2), 231–250.
- Firat, M. & Güngör, M. 2007 River flow estimation using adaptive neuro-fuzzy inference system. *Math. Comput. Simul.* **75** (3–4), 87–96.
- Firat, M. & Güngör, M. 2008 Hydrological time-series modeling using adaptive neuro-fuzzy inference system. *Hydrol. Process.* **22** (13), 2122–2132.
- Gopakumar, R., Takara, K. & James, E. J. 2007 hydrologic data exploration and river flow forecasting of a humid tropical river basin using artificial neural networks. *Water Res. Manage.* **21**, 1915–1940.
- Hankin, B. G., Kettle, H. & Beven, K. J. 2001 Fuzzy mapping of momentum fluxes in complex shear flows with limited data. *J. Hydroinformatics* **3**, 91–103.
- Hundecha, Y., Bardossy, A. & Theisen, H. W. 2001 Development of a fuzzy logic based rainfall-runoff model. *Hydrol. Sci. J.* **46** (3), 363–377.
- Imrie, C. E., Durucan, S. & Korre, A. 2000 River flow prediction using artificial neural networks: generalization beyond the calibration range. *J. Hydrol.* **233**, 138–153.
- Jain, A. & Indurthy, S. K. 2003 Comparative analysis of event based rainfall-runoff modeling techniques—deterministic, statistical, and artificial neural networks. *ASCE J. Hydrol. Eng.* **8** (2), 93–98.
- Kachroo, R. K. 1992 River flow forecasting Part 5. Applications of a conceptual model. *J. Hydrol.* **133**, 141–178.
- Kanso, A., Chebbo, G. & Tassin, B. 2005 Stormwater quality modelling in combined sewers: calibration and uncertainty analysis. *Water Sci. Technol.* **52** (3), 63–71.
- Keskin, M. E., Taylan, E. D. & Yilmaz, G. 2007 Flow prediction model with fuzzy logic approaches: dim stream. In: *International River Basin Management Congress*. Available at: http://www.dsi.gov.tr/english/congress2007/chapter_4/107.pdf
- Kisi, O. 2006 Daily pan evaporation modelling using a neuro-fuzzy computing technique. *J. Hydrol.* **329** (3–4), 636–646.
- Lee, H. K., Oh, K. D., Park, D. H., Jung, J. H. & Yoon, J. 1997 Fuzzy expert system to determine stream water quality classification from ecological information. *Water Sci. Technol.* **36**, 199–206.
- Li, R. & Li, Y. T. 2000 Application of neural networks to sediment laden flow. *ASCE J. Hydraul. Eng.* **6**, 115–121.
- Mehrotra, R. & Sharma, A. 2006 Conditional resampling of hydrologic time series using multiple predictor variables: a K-nearest neighbour approach. *Adv. Water Res.* **29** (7), 987–999.
- Mehta, R. & Jain, S. K. 2008 Optimal operation of a multi-purpose reservoir using neuro-fuzzy technique. *Water Res. Manage.* **23** (3), 509–529.
- Michael, H. A., Mulligan, A. E. & Harvey, C. F. 2005 Seasonal oscillations in water exchange between aquifers and the coastal ocean. *Nature* **436** (7054), 1145–1148.
- Minnes, A. W. & Hall, M. J. 1996 Artificial neural networks as rainfall-runoff models. *Hydrol. Sci. J.* **41** (3), 399–416.
- Mujumdar, P. P. & Kumar, N. D. 1990 Stochastic models of streamflow—some case studies. *Hydrol. Sci. J.* **35**, 395–410.
- Ni, J. R. & Xue, A. 2003 Application of artificial neural network to the rapidfeed back of potential ecological risk in flood inversion zone. *Eng. Appl. Artif. Intell.* **16**, 105–119.
- Ochoa-Rivera, J. C. 2008 Prospecting droughts with stochastic artificial neural networks. *J. Hydrol.* **352**, 174–180.
- Oh, S.-K. & Pedrycz, W. 2006 The design of self-organizing neural networks based on PNs and FPNs with the aid of genetic optimization and extended GMDH method. *Int. J. Approx. Reason.* **43**, 26–58.
- Ondimu, S. & Murase, S. 2007 Reservoir level forecasting using neural networks: Lake Naivasha. *Biosyst. Eng.* **96**, 135–138.
- Pan, T. Y. & Wang, R. Y. 2004 State space neural networks for short term rainfall-runoff forecasting. *J. Hydrol.* **297**, 34–50.

- Partal, T. & Cigizoglu, K. 2008 Estimation and forecasting of daily suspended sediment data using wavelet-neural networks. *J. Hydrol.* **358**, 317–331.
- Rajurkar, M. P., Kothiyari, U. C. & Chaube, U. C. 2004 Modelling of the daily rainfall-runoff relationship with artificial neural network. *J. Hydrol.* **285**, 96–113.
- Rivera, H. & Zamudio, E. 2006 Forecasting methodologies of rivers water levels dynamics in mountain and flats zones. In: *Workshop in Hydrological Forecasting, MADVT-IDEAM, Bogotá, May* (in Spanish).
- Rivera, H., Zamudio, E. & Pinzón, H. 2004 Real time hydrological modeling for navigation sector in Magdalena River. In: *Proceedings of XVI National Colombian Hydraulic and Hydrology Seminar, Colombian Engineering Society, October* (in Spanish).
- Russell, S. O. & Campbell, P. F. 1996 Reservoir operating rules with fuzzy programming. *J. Water Res. Plann. Manage.* **122** (3), 165–170.
- Salski, A. & Holsten, B. 2006 A fuzzy and neuro-fuzzy approach to modelling cattle grazing on pastures with low stocking rates in Central Europe. *Ecol. Informatics* **1** (3), 269–276.
- Şen, Z. & Altunkaynak, A. 2005 A comparative fuzzy logic approach to runoff coefficient and runoff estimation. *Hydrol. Process.* **20** (9), 1993–2009.
- Sivakumar, B. 2006 Nonlinear determinism in river flow: prediction as a possible indicator. *Earth Surf. Process. Landforms* **32** (7), 969–979.
- Sudheer, K. P., Gosain, A. K., Rangan, D. M. & Saheb, S. M. 2002 Modeling evaporation using artificial neural network algorithm. *Hydrol. Process.* **16**, 3189–3203.
- Sudheer, K. P. & Jain, S. K. 2003 Radial basis function neural network for modeling rating curves. *ASCE J. Hydrol. Eng.* **8** (3), 161–164.
- Thirumalaiah, K. & Deo, M. C. 1998 River stage forecasting using artificial neural networks. *ASCE J. Hydrol. Eng.* **3** (1), 26–32.
- Tootle, G. A., Singh, A., Piechota, T. C. & Farnham, I. 2007 Long lead-time forecasting of US streamflow using partial least squares regression. *ASCE J. Hydrol. Eng.* **12** (5), 442–451.
- Wedding, D. K., II & Cios, K. J. 1996 Time series forecasting by combining RBF networks, certainty factors, and the Box-Jenkins model. *Neurocomputing* **10**, 149–168.
- Wong, F. 1991 Time series forecasting using backpropagation neural networks. *Neurocomputing* **2**, 147–159.
- Xiong, L., Shamseldin, A. Y. & O'Connor, K. M. 2001 A non-linear combination of the forecasts of rainfall-runoff model by the first-order Takagi-Sugeno fuzzy system. *J. Hydrol.* **245** (1–4), 196–217.
- Ye, Z., Jin, C. & Pei, T. 2005 Ying Yong Sheng Tai Xue Bao. [Discussion on hydrologic scaling]. *J. Appl. Ecol.* **16** (8), 1537–1540. (in Chinese).
- Yu, P. S. & Chen, C. J. 2000 Application of gray and fuzzy methods for rainfall forecasting. *ASCE J. Hydrol. Eng.* **4** (5), 339–345.
- Zadeh, L. A. 1965 Fuzzy sets. *Inf. Control* **8** (3), 338–353.

First received 25 July 2008; accepted in revised form 19 January 2009. Available online September 2009