

The Lutheran Blood Groups: A Second Example of Anti-Lu^b and Three Further Examples of Anti-Lu^a

By TIBOR J. GREENWALT AND THOMAS SASAKI

CUTBUSH and Chanarin¹ recently described the first example of the expected Lutheran antibody, anti-Lu^b. The original Lutheran antibody, later designated² Anti-Lu^a, was described by Callender and Race³ in 1946. Anti-Lu^a defines the antigen Lu^a which is inherited as a Mendelian dominant character.^{4, 5}

The long wait for anti-Lu^b to show itself is not surprising in view of the extremely low frequency of the genotype Lu^aLu^a . The incidence of the phenotype Lu(a+) is 6.93 per cent in the pooled studies of 2539 English people presented by Mourant.^{3, 6, 7, 8} The genotype frequencies calculated from these data are: $Lu^bLu^b = 0.9307$; $Lu^aLu^b = 0.0681$; $Lu^aLu^a = 0.0012$.

It is our purpose to report a second example of anti-Lu^b found in a Caucasian woman and to record three examples of anti-Lu^a discovered in healthy blood donors.

ANTI-LU^b

Case Report and Family Study

Mrs. S., aged 27, has had three normal pregnancies. She was transfused for the first time on January 24, 1953, two weeks before the birth of her third child. Her "anemia" persisted and a second pint of blood was administered on June 3, 1954. The patient and her husband state that the second transfusion did not seem to do as much good as the first although no specifically unpleasant reaction is recalled.

The present illness started on January 6, 1957 with vaginal hemorrhage complicating the early miscarriage of the patient's fourth pregnancy. Her hemoglobin level was found to be 8.5 Gm. per cent. Two pints of blood were transfused on January 8 and two more on the next day. No symptoms suggesting any type of transfusion reaction were recorded. Her hemoglobin was reported as 11.0 Gm. per cent on January 10, the day of her dismissal from the hospital. On January 18 she noticed that her skin was yellow. Her physician confirmed the presence of jaundice but was unable to arrange for hospitalization until January 22. By that time the jaundice was fading and her total serum bilirubin was reported to be 1.5 mg. per cent with no direct-reacting pigment present. It was noted that her serum was brown and the presence of methemalbumin⁹ was established. Methemalbuminemia was no longer demonstrable on February 1. Her hemoglobin was 9.6 Gm. per cent on admission, was recorded as low as 8.8 Gm. per cent and rose spontaneously to 14.8 Gm. per cent by March 2. The reticulocyte count, which was eight per cent on January 29, decreased to 2.5 per cent on February 7 and is now within normal limits. The occurrence of hemoglobinuria could not be established by history or observation. No enlargement of the liver or spleen was demonstrated.

The case was called to our attention because an indirect Coombs test performed with the patient's serum was found to be positive. On January 26 we were still able to elicit a weakly positive direct Coombs reaction with 1:10 and 1:60 dilutions of antiglobulin serum. The patient's serum gave strongly positive reactions with all eighteen members of our frozen red cell antigen panel by the antiglobulin technic. The presence of an antibody against an antigen of high frequency was suspected. The patient's blood groups were determined as completely as possible in order to ascertain the most likely possibilities.

From the Milwaukee Blood Center, Milwaukee, Wisconsin.

Submitted March 20, 1957; accepted for publication July 1, 1957.

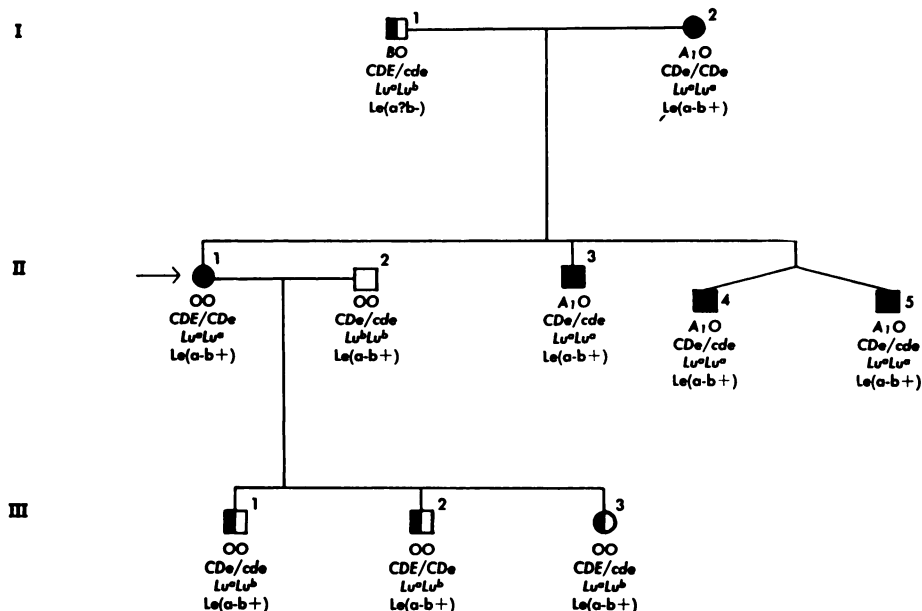

Fig. 1.—The blood groups of the S. family.

Square = male; circle = female; arrow = propositus.

Black = Lu^aLu^a = negative reaction with serum of II-1,
positive reaction with Anti- Lu^a .

Half black = Lu^aLu^b = positive reaction with serum of II-1,
positive reaction with Anti- Lu^a .

Blank = Lu^bLu^b = positive reaction with serum of II-1,
negative reaction with Anti- Lu^a .

Anti-sera used: anti-A, -A₁, -B, anti-M, -N, -S, anti-P, anti-D, -C, -c, -E, anti- Lu^a , anti-K-k, anti- Le^aLe^b , anti-Fy^a, and anti-Jk^a. Complete grouping of each member of pedigree is on file.

She was found to be: O, $NsNs$ U+, P+ Tj(a+), CDE/CD_e , Lu(a+), K-, Le(a-b+), Fy(a+), Jk(a+), Vel+.

The reactions of the patient's red cells with four available anti- Lu^a sera were more strongly positive than usual and therefore the presence of anti- Lu^b was suspected. Our suspicions were strengthened by the results of the family study which are shown in the pedigree (fig. 1). In respect to the Lutheran groups the parents of the propositus (I-1 and I-2) represent a mating with a calculated frequency of 0.0002. Consanguinity of the grandparents and parents of Mrs. S. was denied. The rare genotype Lu^aLu^a is represented five times in two generations (I-2, II-1-3-4-5). Amazingly the entire second generation in the pedigree is Lu^aLu^a . Each of the three children (III-1-2-3) of the propositus possesses the Lu^a antigen, leaving little doubt that she must truly be Lu^aLu^a . No anti- Lu^b activity could be demonstrated in the serum of the other Lu^aLu^a members of the family.

Serologic Studies

It has been established by Race and Sanger¹⁰ that Mrs. S.'s serum does not react with the red cells of Mrs. R., who produced the first example of anti- Lu^b , Mrs. R.'s sister, and the youngest child from one of Callender and Race's³ original families. These three people have the genotype Lu^aLu^a . After neutralization the serum failed to react with the cells of Mrs. S.'s three brothers (II-3-4-5) and her mother (I-2) but retained its activity for other group A and O cells. Consistently strong reactions have been obtained with 59 other Lu(a+) and 17 Lu(a-) cells. The weight of the evidence supporting the identification of the antibody as anti- Lu^b is presented in the following 2 x 2 table.

Agglutination with Serum of Mrs. S.	Test Cells	
	[Lu (a-) + Lu(a+)]	[Lu(a+b-)]
+	76	0
-	0	7

The probability that the antibody in Mrs. S.'s serum is not anti-Lu^b is but one in several thousand millions.

This anti-Lu^b antibody reacts best by the antiglobulin technic. It agglutinates saline suspensions of fresh cells at 37 C. but acts less well at lower temperatures and in bovine albumin. It does not agglutinate trypsinized red cells nor does it produce visible reactions by the Löw¹¹ papain technic. The indirect Coombs reaction is not enhanced by trypsinizing the red cells beforehand.¹² It should be mentioned that at 37 C. it does not consistently agglutinate saline suspensions of erythrocytes which have been stored for six months in glycerine-citrate¹³ at -20 C., although these preparations reacted satisfactorily with almost all other antibodies. It does however give better agglutinations with these specimens by the antiglobulin technic. The results of scoring titrations of the serum against Lu^aLu^b and Lu^bLu^b red cells are shown in table 1. These data indicate that the antibody detects a dosage effect of the Lu^b gene.

ANTI-LU^a

Three examples of anti-Lu^a have been detected among the sera of 18,613 unselected blood donors which have been tested against a two per cent saline suspension of a mixture of three selected bloods at 20 ± 1°C. In each instance the specificity of the antibody was established by using 29 selected red cells. The data are presented in the accompanying 2 x 2 table to indicate the weight of the evidence.

Agglutination with Unknown Sera	Known Cells	
	Lu (a-)	Lu(a+)
+	0	14
-	15	0

p = .000,000,01

TABLE 1.—Titration Scores of Anti-Lu^b with Heterozygous and Homozygous Red Cells

Test Cells	No. of Titrations	Type of Test	Mean Titration Score†
Lu ^a Lu ^b	7	Saline	16 (12-28)‡
		I.C.T.*	20 (10-31)
Lu ^b Lu ^b	10	Saline	25 (14-39)
		I.C.T.	39 (30-58)

* Indirect Coombs Test.

† The titrations were read and scored as described by Callender and Race.³

‡ Numbers in parentheses represent range.

The properties of each anti-Lu^a serum were studied by preparing master dilutions which were then titered against carefully prepared two per cent suspensions of Lu^aLu^b and Lu^aLu^a cells under different conditions. The results are presented in table 2. All react best in saline at 12 C., and their titers decrease as the temperature is raised. They do not perform well in bovine albumin or by the indirect antiglobulin technic.

An attempt was made to determine whether anti-Lu^a could be used to demonstrate a dosage effect of the Lu^a gene by comparing the scores of titrations against Lu^aLu^b and Lu^aLu^a cells in saline at 12 C. Mainwaring and Pickles⁷ found that Lu(a+) cells appear to fall into two categories of weakly and more strongly agglutinable, and therefore a strongly agglutinable Lu^aLu^b cell was selected to make the comparisons more valid. The results (table 2) are suggestive of a dosage effect. With each serum the agglutination in the first two

TABLE 2.—Serologic Characteristics of the Anti-Lu^a Antibodies from Three Caucasian Males

Donor	Nature of Test	Temp.	Test Cell	Reciprocal of Serum Dilution					Score*
				1	2	4	8	16	
Mr. F., age 48, no transfusions, injections of blood or serious illnesses. O, ccDE, Lu(a-b+), Le(a-b+)	Saline	12 C.	Lu ^a Lu ^b	++	++	++	+	(+)	32
			Lu ^a Lu ^a	+++	+++	++	+	W	35
	Saline	23 C.		+	+	+	(+)	W	
		37 C.		+	+	+	(+)	-	
Albumin	37 C.	Lu ^a Lu ^b	+	-	-	-	-		
Anti-globulin	37 C.		W	-	-	-	-		
Mr. M., age 26, no transfusions, injections of blood or serious illnesses. O, CCDee, Lu(a-b+), Le(a-b+)	Saline	12 C.	Lu ^a Lu ^b	++	+++	++	+	(+)	34
			Lu ^a Lu ^a	+++	+++	++	+	+	38
	Saline	23 C.		++	+++	++	+	(+)	
		37 C.		+	++	+	W	-	
Albumin	37 C.	Lu ^a Lu ^b	++	W	-	-	-		
Anti-globulin	37 C.		W	-	-	-	-		
Mr. H., † age 18, transfusion of 1 pint of blood in 1952. A, Rh Positive	Saline	12 C.	Lu ^a Lu ^b	+	(+)	W	-	-	10
			Lu ^a Lu ^a	++	+	W	-	-	15
	Saline	23 C.		(+)	(+)	W	-	-	
		37 C.		(+)	(+)	-	-	-	
Albumin	37 C.	Lu ^a Lu ^b	-	-	-	-	-		
Anti-globulin	37 C.		-	-	-	-	-		

* See legend table 1.

† Serum prepared from ACD plasma by the method of Dunsford and Bowley.¹⁴

tubes of the titration was stronger with Lu^aLu^a cells, but the corresponding titration scores were only slightly higher.

DISCUSSION

The first example of anti- Lu^b recently described by Cutbush and Chanarin¹ was found in a woman who had had three normal pregnancies and no previous transfusions. The antibody was described as a saline agglutinin reacting more strongly at 20 C. than at 37 C. and only poorly in the antiglobulin test. These properties suggest that it was a naturally occurring antibody.

Our patient was transfused in 1953 and 1954. She developed a protracted episode of intravascular hemolysis after receiving four pints of blood in January 1957 as evidenced by transitory methemalbuminemia,⁹ indirect bilirubinemia, reticulocytosis and drop in hemoglobin level. The role of her pregnancies in the isoimmunization cannot be determined. The anti- Lu^b antibody in her serum has the characteristics ascribed to immune varieties of antibodies. It reacts best at 37 C. and in the indirect antiglobulin test. Scores of the antiglobulin titrations (table 1) indicate that this example of anti- Lu^b can distinguish between a single and a double dose of the Lu^b gene.

The paucity of recorded examples of anti- Lu^a has led to the impression that it is of rare occurrence. We could find references to only nine, though doubtless others exist. The presence of three instances in a series of 18,613 blood donors may be taken to indicate that the incidence is greater than was formerly believed.

Three of the recorded samples of anti- Lu^a were complicated by the presence of other antibodies produced by isoimmunization.^{3, 7, 15} Two others were produced by deliberate immunization.⁷ The examples described by Shaw, Mourant, and Ikin¹⁶ and Gonzenbach, Hässig, and Rosin¹⁷ appear to be naturally occurring antibodies. Reference is made by Race and Sanger⁵ to two additional instances but no details are given.

The three anti- Lu^a antibodies which we have described were not accompanied by any unexpected isoagglutinins. Their thermal amplitudes and their poor activity in albumin and in the antiglobulin test are properties attributed to naturally occurring isoagglutinins. Preliminary evidence suggests that anti- Lu^a can, to a limited extent, distinguish between one and two doses of the Lu^a gene.

SUMMARY

1. An example of the blood group antibody, anti- Lu^b , was found in a patient who had a mild hemolytic transfusion reaction. It was shown to possess the characteristics of an immune antibody and to be able to distinguish between a single dose and a double dose of the Lu^b gene.

2. Three new examples of the antibody, anti- Lu^a , are presented. All of them were found in normal blood donors and have properties which indicate that they are naturally occurring antibodies.

Dr. R. R. Race and Dr. R. Sanger confirmed the presence of anti- Lu^b in Mrs. S.'s serum, and studied other members of her family and the three anti- Lu^a sera. We are grateful to them for many favors and their kind encouragement.

We are obligated to Miss Marie Cutbush for making available the $Lu^a Lu^a$ cells from Mrs. R. and her sister, and for a supply of anti- Lu^b serum.

Thanks are due to Dr. A. E. Mourant who furnished our original supply of anti- Lu^a serum and to Dr. Philip Levine for the anti-Tj^a and anti-Vel sera.

We are indebted to Dr. J. M. Fine of Milwaukee for permission to study Mrs. S. and to the patient and her family for their cooperation.

The sera from 18,613 blood donors were studied by Betty McCarthy, Rosemary Polka, Pearl Lemke, Agnes Molnar, Jeannette Flagstadt and Betty Hutter.

SUMMARIO IN INTERLINGUA

1. Un exemplo del anticorpore de gruppo sanguinee, anti- Lu^b , esseva trovate in un patiente qui habeva un leve reaction hemolytic de transfusion. Esseva demonstrate que illo possede le characteristics de un anticorpore immun e que illo es capace a distinguer inter un simple e un duple dose del gen Lu^b .

2. Es presentate tres nove exemplos del anticorpore anti- Lu^a . Illos omnes esseva trovate in normal donatores de sanguine. Lor proprietates indica que illos es anticorpos de occurrentia natural.

REFERENCES

- ¹ CUTBUSH, M., AND CHANARIN, I.: The expected blood-group antibody, anti- Lu^b . *Nature* 178: 855-856, 1956.
- ² A notation for the *Lewis* and *Lutheran* blood group systems. *Nature* 163: 580-581, 1949.
- ³ CALLENDER, S. T., AND RACE, R. R.: A serological and genetical study of multiple antibodies formed in response to blood transfusion by a patient with lupus erythematosus diffusus. *Ann. Eugen.* 13: 102-117, 1946.
- ⁴ LAWLER, S. D.: The inheritance of the *Lutheran* blood groups in forty-seven English families. *Ann. Eugen.* 15: 255-257, 1950.
- ⁵ RACE, R. R., AND SANGER, R.: *Blood Groups in Man*. Oxford, Blackwell Scientific Publications, 2nd edition, 1954, pp. 214-221.
- ⁶ MOURANT, A. E.: *The Distribution of the Human Blood Groups*. Springfield, Charles C. Thomas, 1954, p. 400.
- ⁷ MAINWARING, U. R., AND PICKLES, M. M.: A further case of anti-*Lutheran* immunization, with some studies on its capacity for human sensitization. *J. Clin. Path.* 1: 292-294, 1948.
- ⁸ BERTINSHAW, D., LAWLER, S. D., HOLT, H. A., KIRMAN, B. H., AND RACE, R. R.: The combination of the blood groups in a sample of 475 people in a London hospital. *Ann. Eugen.* 15: 234-242, 1950.
- ⁹ FAIRLEY, N. H.: Methaemalbumin. *Clinical aspects*. *Quart. J. Med.* 10: 95-114, 1941.
- ¹⁰ RACE, R. R., AND SANGER, R.: Personal communication.
- ¹¹ Löw, B.: A practical method using papain and incomplete Rh-antibodies in routine Rh blood-grouping. *Vox Sanguinis* 5: 94-98, 1955.
- ¹² UNGER, L. J., AND KATZ, L.: The effect of trypsin on hemagglutinogens determining eight blood group systems. *J. Lab. & Clin. Med.* 39: 135-141, 1952.
- ¹³ CHAPLIN, H., JR., AND MOLLISON, P. L.: Improved storage of red cells at -20°C . *Lancet* 1: 215-218, 1953.
- ¹⁴ DUNSFORD, I., AND BOWLEY, C. C.: *Techniques in Blood Grouping*. Edinburgh, Oliver and Boyd, 1955, p. 120.
- ¹⁵ HOLLÄNDER, L.: Das *Lutheran-Blutgruppensystem*. Die Häufigkeit des *Lutheran-Antigens* in der Bevölkerung Basels. *Schweiz. Med. Wehnschr.* 85: 10-11, 1955.
- ¹⁶ SHAW, S., MOURANT, A. E., AND IKIN, E. W.: Hypersplenism with Anti-*Lutheran* antibody following transfusion. *Lancet* 2: 170-171, 1954.
- ¹⁷ GONZENBACH, R., HÄSSIG, A., AND ROSIN, S.: Über posttransfusionelle Bildung von Anti-*Lutheran-Antikörpern*. Die Häufigkeit des *Lutheran-Antigens* Lu^a in der Bevölkerung Nord-, West- und Mitteleuropas. *Blut* 1: 272-274, 1955.