

Effects of Implant Drill Wear, Irrigation, and Drill Materials on Heat Generation in Osteotomy Sites

Ki-Tae Koo, DDS, MSD, PhD^{1**}

Min-Ho Kim, DDS, MSD, PhD^{2**}

Hae-Young Kim, DDS, MSD, PhD³

Ulf M. E. Wikesjö, DDS, DMD, PhD⁴

Jae-Ho Yang, DDS, MSD, PhD²

In-Sung Yeo, DDS, MSD, PhD^{2*}

This study evaluated the effects of drill wear on bone temperature during osteotomy preparation with 3 types of drills and compared heat production between drills. The drills used in this study were titanium nitride-coated metal, tungsten carbide carbon-coated metal, and zirconia ceramic drills. An osteotomy 11 mm in depth was formed in bovine scapular bone following the manufacturer's recommended drill sequences. Drilling was performed without irrigation and repeated 20 times; temperature was measured every 5 times. Next, 200 rounds of drilling during irrigation were performed for each drill, with temperature change monitored until round 200. Analysis of variance statistics were used for analyses of the measured data. Drilling without irrigation showed significant thermal increase at all time points compared to drilling with irrigation ($P < .001$). No significant difference was found between drill materials. Under irrigation, the frequency of previous drilling had minimal effects on thermal change. The repeated-measures analysis of variance revealed major thermal change at the initial time point ($P < .0001$), and the multiple comparison tests revealed a significant difference in temperature between the initial drills that had been used 50 or fewer times and those that had been used more than 50 times, irrespective of the drill material. The results of this study indicate that the initial drill should be changed in osteotomy preparation with irrigation after they have been used 50 times. Irrigation may be a more critical factor for the control of temperature elevation than is the drill material.

Key Words: surface contact area, frictional heat, implant drill design, implant drill material, irrigation

INTRODUCTION

Bone tissue necrosis caused by heat induction during drilling may be one of the most important causes of early implant failure.¹⁻³ Since bone tissues are vulnerable to heat, an increase in heat induction during a surgical procedure can damage the bone.⁴ Studies of the enzyme activity of bone tissue have found that irreversible damage can develop after sequential exposure from the insertion of heated implants into the bone for 30 seconds at 50°C and after short exposure at 70°C.⁵ Another study found that bone resorption occurred in 30% of rabbits at 4 weeks after exposure to 47°C heat for 1 minute.²

The frictional heat induced during bone cutting procedures is related to the size and shape of the drill, the drill material, the use of irrigation, and bone density.⁴⁻⁷ Repeated use of a drill accelerates drill wear and lowers the cutting efficiency; this in turn produces more frictional heat, which can cause irreversible damage to the bone.⁸ Repeated washing and sterilization of drills can also accelerate drill wear. The use of different washing agents and sterilization methods can cause wearing of drills based on scanning electron microscopic observations.⁹

Various approaches have been developed to improve the cutting efficiency of implant drills. Titanium nitride (TiN)-coated metal drills or tungsten carbide carbon (WC/C)-coated metal drills are common, commercially available drills. Recently, with the development of zirconia ceramic, the use of ceramic drills has also increased. A ceramic drill is expected to be advantageous because it has excellent biocompatibility and should prevent allergic responses caused by metal particles during drilling with metallic drills. Because they are nonmetallic, the ceramic products are free from corrosion and are expected to produce less frictional heat. However, few studies have compared the heat generated during osteotomy preparation between WC/C-coated metal drills and zirconia drills.

The objectives of the present study were to evaluate the effects of drill wear on bone temperature during osteotomy preparation with TiN-coated metal, WC/C-coated metal, and

¹ Department of Periodontology and Dental Research Institute, School of Dentistry, Seoul National University, Seoul, Korea.

² Department of Prosthodontics and Dental Research Institute, School of Dentistry, Seoul National University, Seoul, Korea.

³ BK21PLUS Program in Embodiment: Health-Society Interaction, Department of Public Health Sciences, Graduate School, Korea University, Seoul, Korea.

⁴ Laboratory for Applied Periodontal & Craniofacial Regeneration, Georgia Health Sciences University College of Dental Medicine, Augusta, Ga.

** These authors contributed equally to this work.

* Corresponding author, e-mail pros53@snu.ac.kr

DOI: 10.1563/AAID-JOI-D-13-00151



FIGURE 1. The implant drill systems. (a) The TiN-coated drill served as a control. The diameters for each drill sequence were 1.8, 2.0, 2.5, 3.2, and 4.2 mm (left to right). The color of the TiN coating was gold, as is typical. (b) The WC/C-coated drill had a black coating. The diameters were 1.5, 2.0, 3.0, 3.4, and 4.3 mm (left to right). Note that the third drill was not a twist drill but a pilot drill that enlarged a hole from 2.0 mm to 3.0 mm in diameter; the pilot drill was used as recommended by the manufacturer. (c) The zirconia ceramic drill was white in color. The diameters were 1.7, 2.0, 2.8, 3.5, and 4.2 mm (left to right).

zirconia ceramic drills and to compare heat production between drills.

MATERIALS AND METHODS

Drill types

Three common, commercially available drill systems were used in this study: a zirconia ceramic drill system (Komet Gerb Brasseler GmbH & Co, Lemgo, Germany), a WC/C-coated drill system (Dentium, Seoul, Korea), and a TiN-coated drill system (Astra Tech, Mölndal, Sweden). The TiN-coated drill system served as the control. Each group consisted of the 5 steps of sequential drilling to reach the planned diameter (4.2–4.3 mm) and final depth (11 mm) of osteotomy. Figure 1 summarizes the characteristics of the drills used in this experiment.

System configuration and temperature measurement system

Bovine scapular bone with bone density similar to D₂ bone and sharing many characteristics with the mandibular bone, was prepared as bone fragments with a thickness of 15–20 mm, horizontal length of 35 mm, and vertical length of 40–55 mm. Fragments with a cortical bone thickness of 2–3 mm were selected as the samples for this study. The experimental set-up was designed so that half the volume of the frozen samples was immersed in a 36.5°C water bath filled with 0.9% physiological salt solution (room temperature 24°C) for 2 hours before the experiment in order to attain a mean internal temperature of 36.5°C and a surface temperature of 28°C. Temperature measurements were made with the thermocouple TT-K-40-25 (Omega Engineering, Inc, Stamford, Conn), which was connected to a data logger (GL800, Graphtec Co, Yokohama, Japan) that recorded temperature over time. The temperature recording system allowed detailed measurement of temperature in 0.2-second units. A specially-designed suspension device (Applied Mechanics Co, Seoul, Korea) was used to position the thermocouple as close as possible to the drilling osteotomy. The suspension system established a vertically-oriented puncture route by fixing with a handpiece. The thermocouple was adjusted to within 0.2 mm of the final drilling position. The insertion route was formed with a 0.9-mm

drill. Temperature was measured at 4-mm and 10-mm depths. After insertion of the thermocouple, the entrance of the insertion route was sealed with sticky wax to limit the cooling effects of the water (Figure 2).

Operational procedure

To avoid dislodging the initial drill from its designated position, a #330 bur was used to form a guide hole with an initial depth of 1 mm. An osteotomy 11 mm in depth was formed with the drills in the order of initial, intermediate, and final drills in

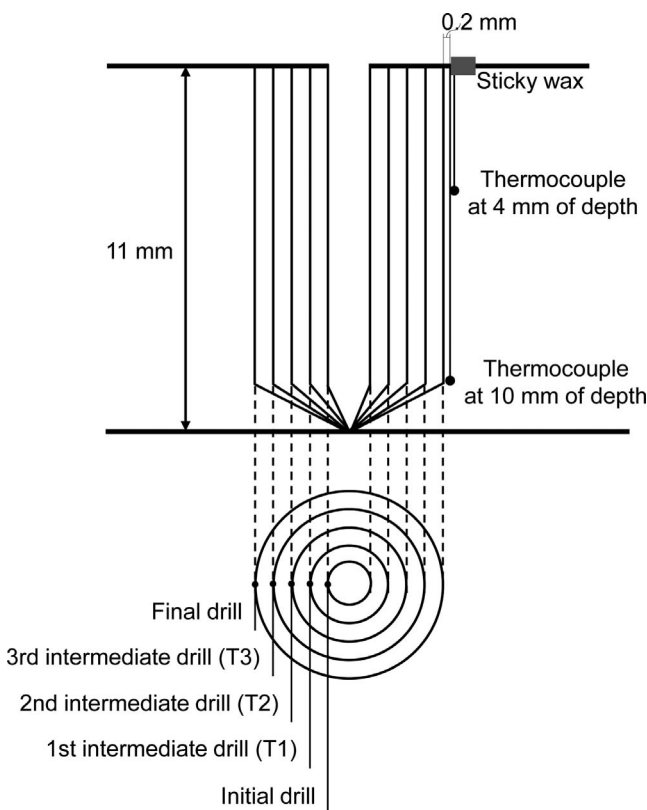

FIGURE 2. Schematic diagram of the drill sequence and location of the thermocouples. Sticky wax (gray rectangle) was used to protect the thermocouples from environmental effects, such as the cool water.

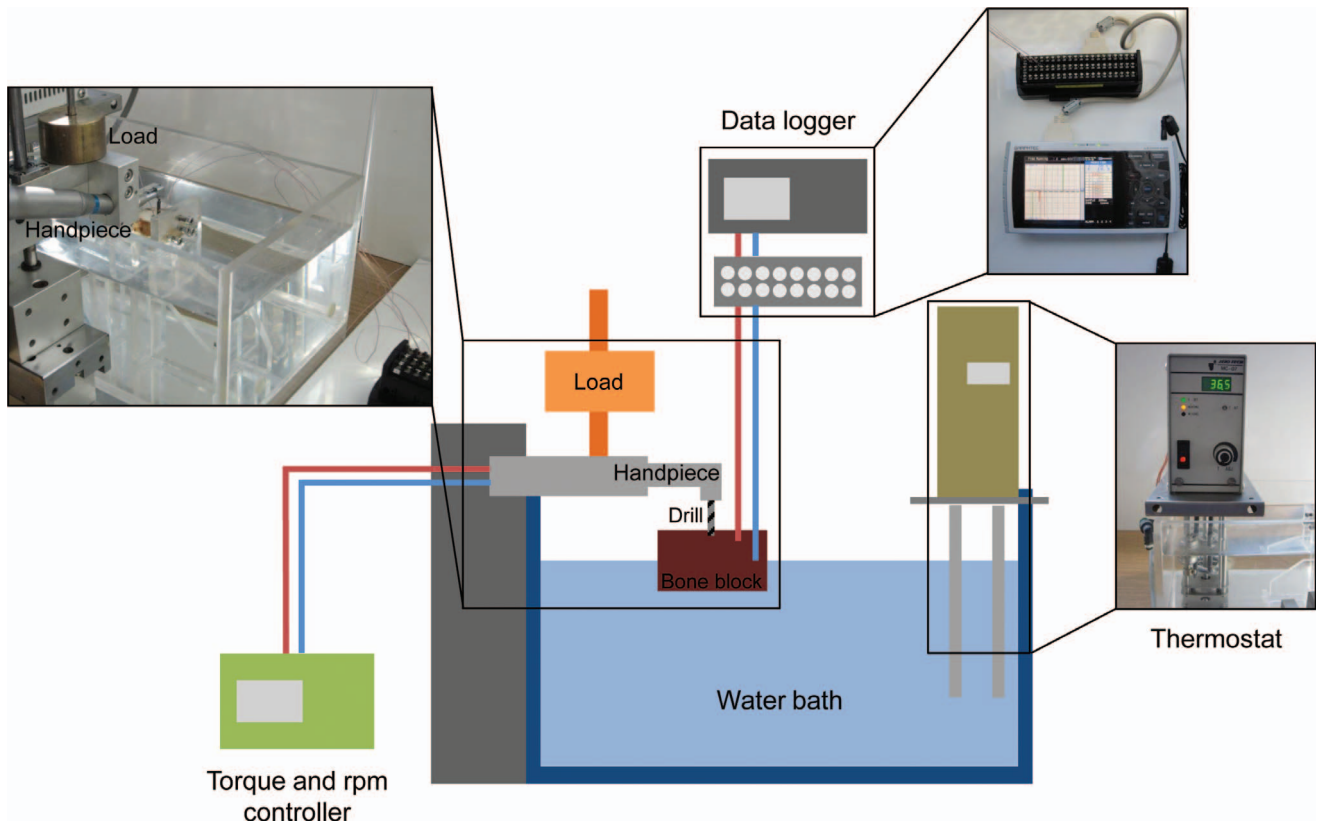

FIGURE 3. Schematic representation of the equipment used to measure temperature, plus photos of a data logger, thermostat, and handpiece. The data logger recorded the bone temperature during drilling. The thermostat maintained a temperature of 36.5°C in the water bath.

accordance with the manufacturer's recommendations. The rotational speed was 3000 rpm, and the torque, 30 Ncm. The basic loading condition was set at 750 g with an additional 500-g load added only if early penetration of the compact bone was considered difficult (Figure 3). Each experimental group was first tested without irrigation, and the process was repeated 20 times with temperature measurements occurring at 5, 10, 15, and 20 times of use.

Next, a test was performed with irrigation using a physiological salt solution stored at 18°C with a uniform irrigation speed of 90 mL/min (external irrigation). A total of 200 rounds of tests were performed for each drill type, with temperature measurements occurring every 5 times until round 50 and every 10 times thereafter until round 200. The drills were autoclaved after every 5 times of use to mimic the clinical setting.

Statistical analysis

The results of a normality test indicated that the measured temperatures had a normal distribution ($P > .05$). The mean and standard deviation of temperature were used as summary statistics. The effects of the drilling sequence on bone temperature were evaluated for the 5 steps of sequential drilling required to reach the desired osteotomy size in each group. These 5 steps were classified as initial, T1, T2, T3, and final (Figure 2). A 2-way analysis of variance (ANOVA) was used to compare temperature change in relation to the drill type and

the use of irrigation at each step of the drilling sequence (initial, T1, T2, T3, and final). A repeated-measures ANOVA was used to compare temperature change during irrigation between the 5 steps of drilling. The Tamhane multiple comparison method was used because the equal variance assumption was rejected ($P = .026$). All analyses were performed with SPSS software version 20.0 (SPSS Inc, Chicago, Ill). The type I error rate was set at .05.

RESULTS

Thermal change in relation to irrigation and drill material

Temperature in relation to irrigation (ie, with or without irrigation) and drill material was assessed up to 20 rounds of drilling for each step of the drilling sequence (Table 1). The 2-way ANOVA revealed that temperature was influenced by irrigation ($P < .001$) but not by drill type ($P > .05$). A statistically significant difference was observed in favor of irrigation ($P < .001$); conditions without irrigation showed higher thermal change at all time points. No significant difference in temperature was found between drill types.

Effects of drill wear on temperature change

For the irrigation samples, the temperature was significantly higher for the initial drill ($P < .0001$), and multiple comparison

TABLE 1

Temperature in relation to drill type and irrigation. Values are means (standard deviations) for the first 5 to 20 times of use. (unit: °C)*

| Drill types | N | Initial | | T1 | | T2 | | T3 | | Final | |
|-----------------------|----|------------|------------|------------|------------|------------|------------|------------|------------|-------------|------------|
| | | WOI | WI | WOI | WI | WOI | WI | WOI | WI | WOI | WI |
| TiN coated | 4 | 41.7 (2.3) | 32.9 (3.2) | 39.0 (2.1) | 30.1 (1.6) | 44.2 (3.8) | 29.3 (0.4) | 48.8 (1.9) | 32.3 (1.4) | 64.7 (5.4) | 32.2 (0.8) |
| WC/C coated | 4 | 47.2 (5.3) | 35.3 (3.8) | 34.4 (2.9) | 31.2 (2.9) | 46.2 (4.7) | 32.2 (2.6) | 43.7 (9.2) | 35.1 (2.3) | 64.0 (12.7) | 31.1 (1.4) |
| Zirconia ceramic | 4 | 46.4 (2.1) | 33.5 (4.4) | 36.7 (1.4) | 30.7 (0.8) | 45.3 (3.6) | 31.2 (1.9) | 47.1 (1.9) | 32.9 (1.2) | 51.5 (5.2) | 32.1 (3.4) |
| Total | 12 | 45.7 (3.4) | 33.8 (3.7) | 37.2 (2.5) | 31.4 (2.7) | 46.0 (3.6) | 31.6 (2.4) | 44.2 (5.4) | 32.3 (2.5) | 65.2 (11.3) | 31.5 (2.0) |
| P-value (irrigation) | | < .001 | | < .001 | | < .001 | | < .001 | | < .001 | |
| P-value (drill types) | | .114 | | .303 | | .284 | | .865 | | .137 | |

*WOI indicates without irrigation; WI, with irrigation.

tests revealed a statistically significant difference in temperature between the initial drills that had been used 50 or fewer times and those that had been used more than 50 times for the three drill types. The mean temperature was less than 37°C for the initial drills used 50 or fewer times, and over 43°C for the drills used more than 50 times (Table 2). No significant effect of drill wear was observed at T1, T2, T3, or the final measurement; the frequency of previous drilling showed minimal effects on thermal change.

DISCUSSION

This study evaluated the effects of drill wear on heat generation during osteotomy preparation. Our results indicate that when an initial drill has been used more than 50 times, it leads to significantly higher temperatures during drilling than when used less than 50 times. Thus, the critical threshold for drill wear appears to be around the 50th time of use, which is consistent with the results of a previous study.¹⁰ Our results are also in agreement with the guidelines provided by the manufacturers of the drills used in this study; these guidelines recommend 40–50 times of use drilling with irrigation. In daily practice, most clinicians simply use a timeframe (eg, 6 months) to determine when to switch to a new drill. Since frequency of drill use may vary significantly between practices, it seems better to follow guidelines based on the frequency of use rather than time intervals. Although our results indicate that an initial drill should be replaced after 50 times of use for TiN-coated metal, WC/C-coated metal, and zirconia ceramic drills, it is possible that other variables, such as the amount of bone to be cut, the

sharpness of the drills, the depth of bone cutting, and the thickness of the cortical bone, could also affect drill wear.

Our results indicate that irrigation significantly reduced heat during drilling. We compared the temperature during drilling with and without irrigation, and we found that drilling without irrigation was associated with significantly higher temperatures at all time points than was drilling with irrigation. No significant differences in temperature were observed between the different drill types during irrigation. These findings are consistent with those of previous studies that found that if bone cutting occurs during irrigation at the time of drilling, the cooling or lubrication effect of the irrigation reduces frictional heat and leads to a better bone response.¹¹ Since the discontinuation of irrigation can elevate temperature above the threshold temperature near the final drilling sequence, it appears that irrigation is most important when the drilling sequence reaches the final drill size. Indeed, the use of a 2-mm drill without irrigation can lead to a drill temperature as high as 171.3°C after bone cutting.⁷

The type of drill seemed to have a smaller effect on bone temperature than the use of irrigation. Furthermore, the bone temperature tended to be affected by the sequence of drilling rather than the frequency of drilling. Under irrigation, no drastic temperature elevation above the threshold was observed throughout the study even if the drills were used more than 200 times. However, the significant difference detected between the initial drilling point and the rest of the drilling sequence should not be discounted. It is probable that the bone temperature pattern was mainly attributable to the excessive delay of drilling at the upper cortical bone due to the presence of the cortical portion, which may have increased the

TABLE 2

Temperature in relation to the drilling sequence (initial, T1, T2, T3, and final) and the number of times that the drill had been used for the 3 drill types combined (TiN-coated metal, WC/C-coated metal, and zirconia ceramic drills) with irrigation. Group = number of times of use. Values are means (standard deviations).*

| Group | N | Initial | T1 | T2 | T3 | Final |
|---------|----|-------------------------|------------|------------|------------|------------|
| 5–25 | 15 | 34.3 (4.1) ^a | 30.6 (1.8) | 31.1 (2.1) | 32.9 (2.2) | 32.3 (2.2) |
| 30–50 | 15 | 36.8 (4.4) ^a | 29.9 (1.9) | 32.2 (2.0) | 32.3 (2.6) | 33.1 (2.4) |
| 60–100 | 15 | 43.9 (2.2) ^b | 30.9 (2.1) | 32.8 (2.0) | 32.8 (3.1) | 32.4 (2.8) |
| 110–150 | 15 | 43.3 (4.1) ^b | 30.9 (2.1) | 32.5 (2.4) | 32.1 (2.6) | 32.9 (2.5) |
| 160–200 | 15 | 44.4 (2.6) ^b | 32.1 (2.5) | 31.8 (2.0) | 32.8 (2.2) | 32.5 (2.1) |
| Total | 75 | 40.6 (5.4) | 30.8 (2.1) | 32.1 (2.1) | 32.6 (2.5) | 32.7 (2.4) |
| P-value | | < .0001 | .080 | .199 | .908 | .876 |

*Different letters, a and b, mean significant differences at the significance level of 0.05 by the Tamhane multiple comparison test.

peripheral temperature of the bones, although the thermocouple was located below the cortical bone in this study to measure the temperature stably and to minimize the water cooling effect in the measurement. At the time of bone penetration, the drill rotation at the cortical bone tended to show a standstill rotation by increasing frictional heat development, which may have been directly transferred to the bone, causing rapid temperature elevation. Therefore, rapid penetration of the cortical bone may be recommended to minimize heat transfer, and more frequent replacement of at least the initial drills could be an efficient bone cutting strategy. Finally, it may be practical to apply rapid bone cutting for the initial drilling when the drill has to address the compact cortical bone and to use more detailed drilling afterwards as the bone cutting gets closer to the final step of drilling.

This study has some limitations. The sample size was relatively small, and the drills that we tested had different diameters and shapes. This limited our interpretation of the results, although it should be noted that we followed the recommended drill sequences of the manufacturers. Future studies that evaluate the performance of drill materials should use drills that all have the same dimensions but are composed of different materials. Future studies should also test a larger number of drills to ascertain whether ceramic drills have any advantages over metallic drills.

CONCLUSIONS

The results of this study indicate that an initial drill for implant insertion, which penetrates the bone first, should be changed after they have been used about 50 times. Not all drills appear to need to be changed out after 50 uses, when used with irrigation. This study also confirms that irrigation is more critical to the control of temperature elevation than drill materials.

ABBREVIATION

WC/C: tungsten carbide carbon

REFERENCES

1. Eriksson A, Albrektsson T, Grane B, McQueen D. Thermal injury to bone. A vital-microscopic description of heat effects. *Int J Oral Surg*. 1982;11:115–121.
2. Eriksson AR, Albrektsson T. Temperature threshold levels for heat-induced bone tissue injury: a vital-microscopic study in the rabbit. *J Prosthet Dent*. 1983;50:101–107.
3. Eriksson RA, Albrektsson T. The effect of heat on bone regeneration: an experimental study in the rabbit using the bone growth chamber. *J Oral Maxillofac Surg*. 1984;42:705–711.
4. Brisman DL. The effect of speed, pressure, and time on bone temperature during the drilling of implant sites. *Int J Oral Maxillofac Implants*. 1996;11:35–1137.
5. Lundskog J. Heat and bone tissue. An experimental investigation of the thermal properties of bone and threshold levels for thermal injury. *Scand J Plast Reconstr Surg*. 1972;9:1–80.
6. Ercoli C, Funkenbusch PD, Lee HJ, Moss ME, Graser GN. The influence of drill wear on cutting efficiency and heat production during osteotomy preparation for dental implants: a study of drill durability. *Int J Oral Maxillofac Implants*. 2004;19:335–349.
7. Yacker MJ, Klein M. The effect of irrigation on osteotomy depth and bur diameter. *Int J Oral Maxillofac Implants*. 1996;11:634–638.
8. Matthews LS, Hirsch C. Temperatures measured in human cortical bone when drilling. *J Bone Joint Surg Am*. 1972;54:297–308.
9. Jochum RM, Reichart PA. Influence of multiple use of Timedur-titanium cannon drills: thermal response and scanning electron microscopic findings. *Clin Oral Implants Res*. 2000;11:139–143.
10. Oliveira N, Alaejos-Algarra F, Mareque-Bueno J, Ferres-Padro E, Hernandez-Alfaro F. Thermal changes and drill wear in bovine bone during implant site preparation. A comparative in vitro study: twisted stainless steel and ceramic drills. *Clin Oral Implants Res*. 2012;23:963–969.
11. Harder S, Egert C, Wenz HJ, Jochens A, Kern M. Influence of the drill material and method of cooling on the development of intrabony temperature during preparation of the site of an implant. *Br J Oral Maxillofac Surg*. 2013;51:74–78.