

# Effect of Steam Autoclaving on the Tensile Strength of Resin Cements Used for Bonding Two-Piece Zirconia Abutments

Marcos Alexandre Fadanelli, DDS, MS  
 Flávia Lucisano Botelho do Amaral, DDS, MS, PhD  
 Roberta Tarkany Basting, DDS, MS, PhD  
 Cecilia Pedrosa Turssi, DDS, MS, PhD  
 Bruno Salles Sotto-Maior, DDS, MS, PhD  
 Fabiana Mantovani Gomes França, DDS, MS, PhD\*

The purpose of this study was to evaluate the effects of steam autoclave sterilization on the tensile strength of two types of resin cements used to bond customized CAD/CAM zirconia abutments onto titanium bases. Forty sets of zirconia abutments cemented to screwed titanium bases of implants analogs were divided into 4 groups ( $n = 10$ ). Two groups were treated with a conventional chemically activated resin cement (ML, Multilink Ivoclar Vivadent) and the other two groups with a self-adhesive dual resin cement (RelyX U200, 3M ESPE). One group from each cement was submitted to steam autoclaving. The autoclave sterilization cycle was performed after 72 hours of cementation for 15 minutes at  $121^{\circ}\text{C}$  and  $2.1 \text{ Kg/cm}^2$ . The samples were subjected to tensile strength testing in a universal testing machine (200 Kg, 0.5 mm/min), from which the means and standard deviations were obtained in Newtons. Results showed (via ANOVA and Tukey's test;  $\alpha = 0.05$ ) that in the absence of steam autoclaving, no difference was observed in tensile strength between the cements tested: ML: 344.87 (93.79) and U200: 280 (92.42) ( $P = .314$ ). Steam autoclaving, however, significantly increased tensile strength for the ML: 465.42 (87.87) compared to U200: 289.10 (49.02) ( $P < .001$ ). Despite the significant increase in the ML samples ( $P = .013$ ), autoclaving did not affect the tensile strength of the U200 samples ( $P > 0.05$ ). The authors concluded that steam autoclaving increases the mean tensile strength of the chemically activated cement compared to the dual-cure self-adhesive cement. The performance of both cements evaluated was similar if the sterilization step was disconsidered.

**Key Words:** resin cements, dental implant-abutment design, sterilization, tensile strength

## INTRODUCTION

Functional and biological success of implant-supported restorations has raised the bar on the definition of treatment success in the form of additional criteria, such as esthetics.<sup>1</sup> Conventional titanium abutments show high longevity due to their physical properties.<sup>2</sup> Nevertheless, when titanium abutments are used in patients with a thin periodontal phenotype, a gray shadow becomes noticeable through the mucosa transpiring the metal component, thus compromising the esthetic outcome.<sup>3,4</sup>

Esthetic deficiencies relating to titanium have encouraged the development of ceramic materials as an alternative for highly esthetic areas.<sup>1</sup> Prestipino and Ingber<sup>5</sup> proposed the use of the first ceramic abutments, which were made of alumina-reinforced ceramic. In search of a ceramic material for abutments with better physical properties, yttrium-stabilized zirconia was introduced in 1996, with a fracture resistance approximately twice that of alumina.<sup>6</sup> As well as esthetics, such ceramics display similar biocompatibility to titanium<sup>7</sup> and a low degree of biofilm adherence.<sup>8</sup> Zirconia abutments can be

customized creating a more superficial crown-abutment line of cement in relation to the gingival margin, placed slightly into the crevicular sulcus.<sup>9</sup>

The base of the of zirconia abutment, which is the region that connects to the implant platform, has a high incidence of stress; this can lead to failures in the single-piece zirconia abutments.<sup>10</sup> To ameliorate this drawback, a titanium base can be screwed into the implant onto which the customized zirconia abutment can be cemented.<sup>10-13</sup> Retention of the titanium-based zirconia-abutment is therefore achieved via the cement.<sup>11</sup>

Resin cements are commonly used for fixing restorations (ceramic or resin) and can be bonded to both the tooth structure and the restoration, resulting in good esthetic and mechanical properties.<sup>14</sup> These cements are composed of methacrylate monomers with different molecular weights and inorganic particles treated with silane. The curing mechanisms of such materials can be chemical, light-induced, or dual. Dual-activation cements have both forms of polymerization (chemical and physical) that are supplementary yet not independent.<sup>15</sup> Several factors can influence cement polymerization—such as chemical composition, thickness, opacity, and the shade of the ceramic material that can attenuate the passage of light—that can result in a decreased polymerization capacity of the cement.<sup>16</sup> Chemical or dual-cure cements have been suggested to cement zirconia abutments onto the titanium

São Leopoldo Mandic Institute and Dental Research Center, Campinas/SP, Brazil.

\* Corresponding author, e-mail: biagomes@yahoo.com

DOI: 10.1563/aaid-joi-D-16-00018

TABLE 1

Composition, lots, and manufacturers' instructions of cements used\*

Brand and Batch No.	Manufacturer	Composition	Mixing Instructions
Multilink N79065	Ivoclar Vivadent, Schaan, Liechtenstein, Germany	Bis-EMA ethoxylate, UDMA, Bis-GMA and HEMA, barium glass, ytterbium trifluoride, and spheroidal mixed oxides.	Multilink is dispensed from the syringe in the correct ratio through simultaneous dosing on a mixing pad. Manual mixing of base and catalyst pastes for 10 sec and application to the desired surface.
RelyX U200 Clicker 499518	3M ESPE, St Paul, Minn	Methacrylate monomers containing phosphoric groups, silanized silica, calcium hydroxide, titanium dioxide, dimethacrylates, dyes, camphorquinone, primers for self-reaction.	RelyX U200 is dispensed through the clicker system with a simultaneous dosage. Manual mixing of base and catalyst pastes on a mixing pad for 10 sec and application to the desired surface.

\*Bis-EMA indicates ethoxylated bisphenol-A dimethacrylate; UDMA, urethane dimethacrylate; Bis-GMA, bisphenol-glycidyl-methacrylate; HEMA, 2-hydroxydoethyl methacrylate.

base because of the difficulty of cement light curing under the zirconia abutment.<sup>15</sup> The maximum human bite force may range from 90 to 370N, averaging 270N. In such scenario, abutment cementation onto titanium bases should be able to bear such forces, including masticatory movements. The cementation line should not come loose while the prosthetic restoration remains in function in the oral cavity,<sup>17</sup> thus reiterating the importance of adequate mechanical properties of the cement.<sup>14</sup>

The cementation step introduces a handling stage that may risk bacterial contamination of the surfaces in contact with the cement. Therefore, cementation of the zirconia abutment to the titanium base should be performed prior to sterilization so that a bacteria-free surface can be obtained, increasing the chances of epithelial adhesion and thus reducing the risk of peri-implantitis.<sup>18,19</sup> However, the effect of sterilization on the zirconia-titanium abutment interface when chemically or dual-cure cements are used is yet unknown. The temperature and pressure of the steam autoclaving method may affect the zirconia-titanium bonding interface.

Therefore, the aim of this study was to evaluate the effect of steam autoclave sterilization on the tensile strength of two types of resin cements, a conventional chemically activated resin cement (Multilink Ivoclar Vivadent, Schaan, Liechtenstein, Germany) and a dual cure self-adhesive resin cement (RelyX U200, 3M ESPE, St Paul, Minn) used to bond customized CAD/CAM zirconia abutments onto titanium bases. The null hypothesis tested was that different types of resin cements and steam autoclaving did not affect the tensile strength of zirconia abutments bonded to titanium bases.

## MATERIALS AND METHODS

### Experimental design

The experimental units consisted of 40 samples of customized CAD/CAM zirconia abutments cemented onto titanium bases screwed onto implant analogs. The response variable was the tensile strength of zirconia abutments. The study factors were "cements" on two levels: conventional chemically activated resin cement (Multilink, Ivoclar Vivadent, Schaan) and dual-cure

self-adhesive resin cement (Rely X U200 3M ESPE) and "autoclaving" on two levels: without steam autoclaving (control) and steam autoclaving 72 hours after the cementation. The studied factors were assigned to experimental units randomly forming four experimental groups (n = 10): group 1: chemically activated resin cement (Multilink) without sterilization; group 2: self-adhesive resin cement (RelyX U200) without sterilization; group 3: chemically activated resin cement (Multilink) with sterilization; group 4: self-adhesive resin cement (RelyX U200) with sterilization. Two cementing agents used in this study and their characteristics are described in Table 1.

### Test specimens and cementation procedures

Forty customized zirconia abutments (InCoris Zr, Sirona Dental Systems, New York, NY) were obtained by milling in a CAD/CAM system (in Lab, Sirona Dental Systems), and subsequent sintering designed without a central perforation through which the retaining screw would be activated, stabilizing the titanium base connected to the platform of the implant analog. The abutments were made of zirconia measuring 4 mm in height, 7 mm in outer diameter, with a wall thickness of 1.5 mm.

The 40 zirconia abutments were cemented over 40 titanium bases (Abutment-Amplified cemented cylinder, P-I Brånemark Philosophy, Sävedalen, Sweden). The titanium base has a mild vertical taper and a seating ring of 4.75 mm in diameter (Figure 1). The abutments were made of zirconia with a 1.1-mm shoulder beyond the edge (overcontour) of the titanium seating ring (Figure 2).

The titanium bases were sandblasted for 10 seconds from a 10-mm distance using 50-micron aluminum oxide particles, 2 bar of pressure and a rotating movement.

All 40 zirconia abutments were cleaned internally with isopropyl alcohol and received a layer of zirconia primer (applied with a disposable brush for 180 seconds) and then scattered with jets of air (Metal/Zirconia Primer, Ivoclar Vivadent, Schaan).

The cements were handled according to manufacturer recommendations (Table 1) in a controlled temperature room at  $24 \pm 1^\circ\text{C}$ . The amount of cement used was 0.3 grams. A disposable brush was used to carry and apply the cement to

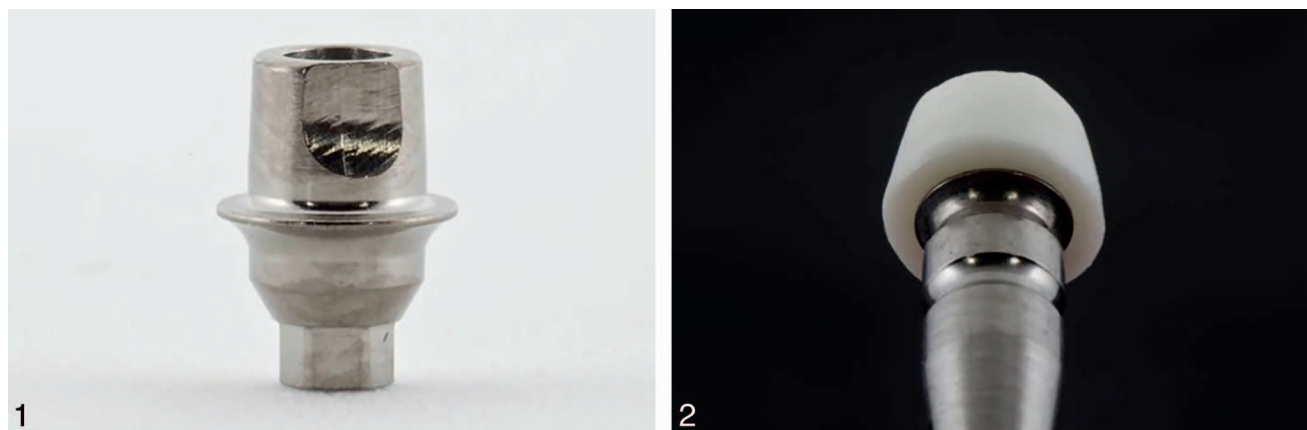

**FIGURES 1 AND 2.** **FIGURE 1.** Abutment-Amplified cemented cylinder (P-I Branemark Philosophy). **FIGURE 2.** Relationship between the thickness of the Ti base ring and the Zr abutment.

the titanium bases, and the internal surface of the abutments was carried out using a disposable microbrush. The screw access holes in the titanium bases were sealed with polytetrafluoroethylene tape (Amanco, São Paulo/SP, Brazil) prior to cement application. The abutments were accommodated manually onto the bases using finger pressure. The excess cement found around the samples was removed with a brush and then placed in a manual press under 5 kg of pressure for 10 minutes.<sup>20</sup>

The samples cemented with the dual-cure self-adhesive cement U200 were then light-cured for 40 seconds on each side using an LED light set to 1200 mW/cm<sup>2</sup> (Call Radii, SDI, Bayswater, Victoria, Australia).

#### **Steam autoclaving**

After 72 hours, the specimens from groups 3 and 4 were placed in special autoclaving pouches made from surgical grade paper and laminated polyester film/polypropylene. They were sterilized in a 15-minute cycle at 121 centigrades and under 2.1 Kg/cm<sup>2</sup> of pressure (Autoclave AHMC 21L, Sercon Industry and Commerce, Mogi das Cruzes/SP, Brazil). Groups 1 and 2 were stored in an incubator at 37°C during the sterilization period.

#### **Tensile strength test**

All samples were subjected to tensile testing in a universal testing machine (DL2000, EMIC, São José dos Pinhais/PR, Brazil) at a speed of 0.5 mm/min and a load cell of 200 Kg.

For the tests to be performed securely, a special device was custom made so that no artifact needed to be welded onto the

abutment and the analog. A threaded metal device was prepared to permit that the analog passed through it<sup>21</sup> (Figure 3). The 1.1-mm abutment overhang made of zirconia was used as retention by mechanical imbrication for the tensile test, which allowed it to become trapped inside the device. A second device was used so that the slot in the apical portion of the analog of the hexagonal abutment fit and remained locked during the test.

#### **Resin cement residue index**

The resin cement residue index was evaluated for each sample tested under a 3.5× optical magnification (SurgiTel Front-Mounted Lens, TTL, Ann Arbor, Mich). Each sample was classified into one of three scores: A, resin cement fully adhered to the zirconia abutment; B, resin cement fully adhered to the titanium base; C, mixed.

#### **Statistical analysis**

The data were submitted to the two-way (cement and autoclaving) analysis of variance (two-way ANOVA). The comparison between the groups was performed using the Tukey test. All tests adopted a statistical significance level of 5%.

#### **DISCUSSION**

Zirconia abutments are used because of their esthetic advantage over titanium abutments in patients with a thin

Cement	Sterilization	
	With	Without
Self-cure resin cement (Multilink)	344.87 (93.79) Aa	465.42 (87.87) Ba
Self-adhesive resin cement (U200)	280.06 (92.42) Aa	289.10 (49.02) Ab

\*Different capital letters indicate a significant difference between autoclaving treatments. Different lowercase letters indicate a significant difference between cement treatments.

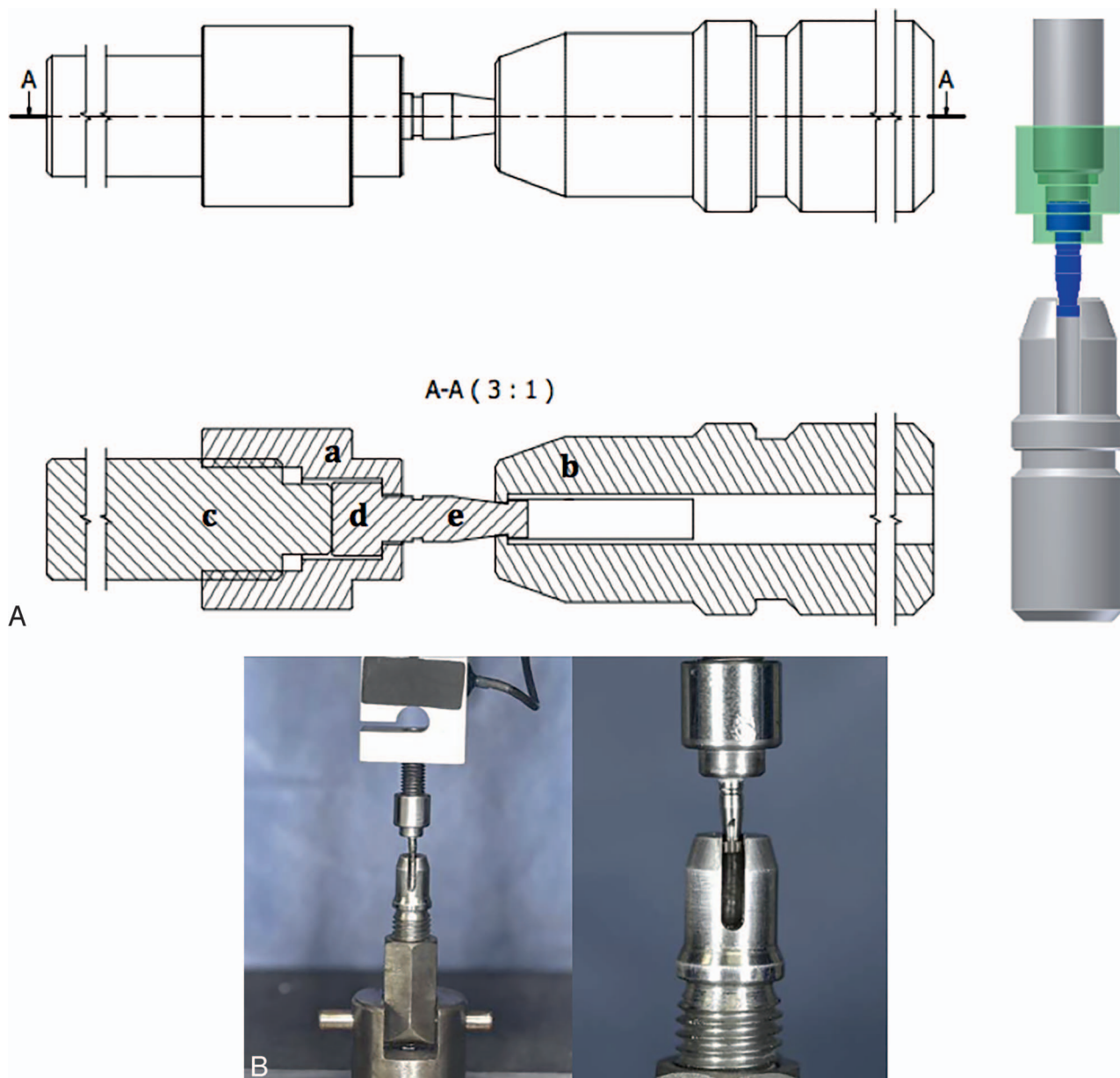

**FIGURE 3.** (A) Schematic outline of the device used for the test. a: Metal device that was turned internally, so that the portion of the analog and the zirconia abutment would pass through it (this device is connected to the load cell); b: another device was made by hollowing a steel cylinder so the groove in the apical portion of the implant analog would fit and remain fixed (this device is attached to the base of the universal test machine); c: device screwed into a metal apparatus to secure the zirconia abutment in position; d: zirconia abutment; e: implant analog. (B) Tensile test moment.

gingival biotype. It is known, however, that single-piece zirconia abutments may show mechanical incompatibility, leading to loosening of the implant screw, wear of the interface between the implant and the abutment, and an increased marginal gap.<sup>10,22</sup> Therefore, an intermediate titanium component is recommended.<sup>23</sup> The use of chemically activated or dual-cure cements is generally advised when cementing two-piece zirconia abutments because of the difficulty of light curing under the zirconia abutment.<sup>12,24</sup>

In the absence of sterilization, the tensile strength was similar for both groups tested. This result is consistent with those by Gehrke et al.,<sup>12</sup> who also found no difference between

the resin cements regarding the tensile strength of two-piece zirconia abutments. Similar performance between the cements can be justified on the similarity in composition between the materials used.

The Multilink material is classified as a conventional chemically activated cement composed of Bis-EMA, ethoxylated UDMA, Bis-GMA, HEMA, barium glass, ytterbium trifluoride, and spheroidal mixed oxides. A primer is also part of the bonding system, which should be applied on both metal and zirconia surfaces when they are to be bonded together.<sup>25</sup> RelyX U200 is classified as a dual-cure self-adhesive cement. It does not require pretreatment of the tooth surface, as it is composed of

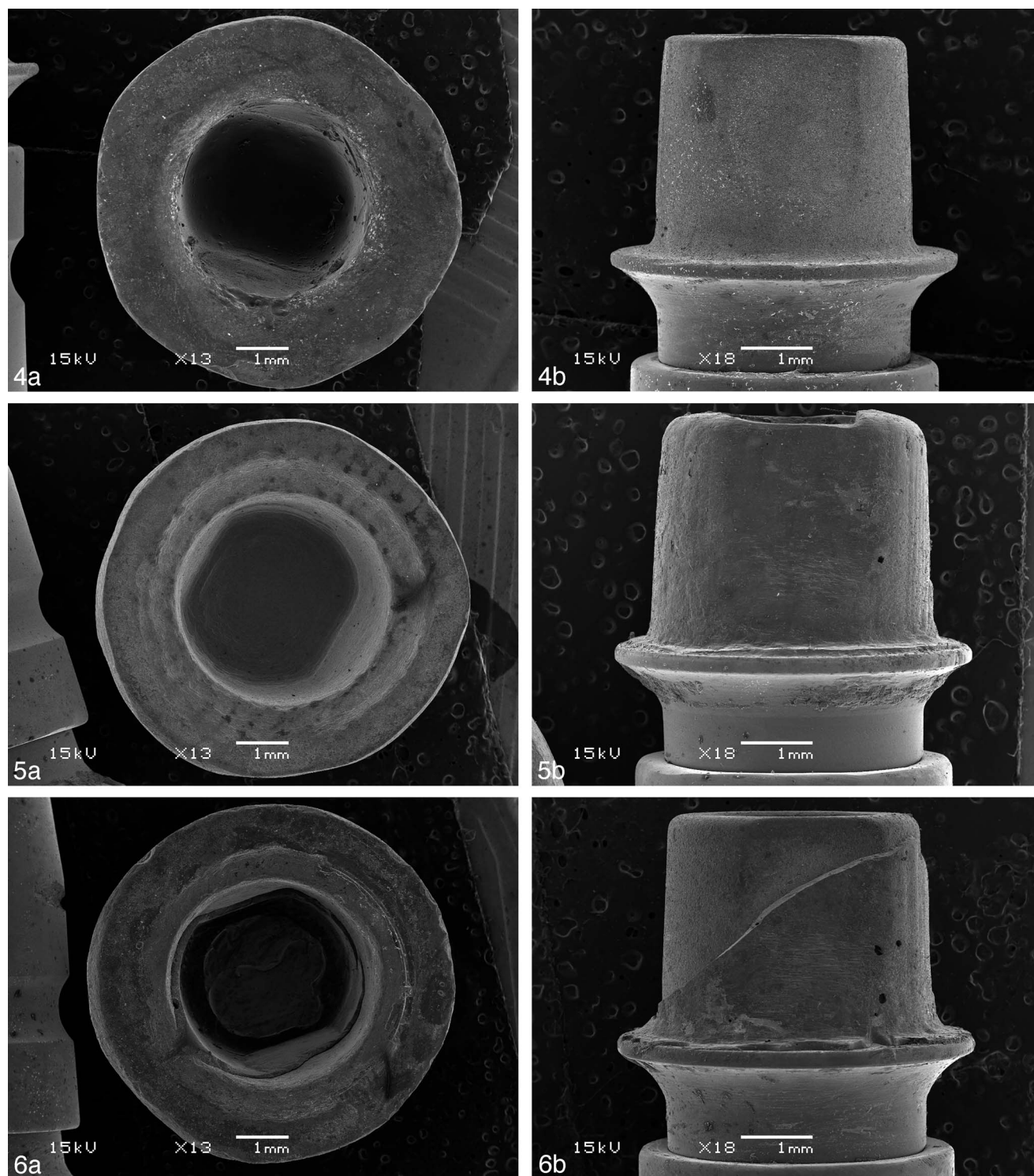

**FIGURES 4–6. FIGURE 4.** (a) Illustration of the resin cement fully adhered to the zirconia abutment. (b) Implant analog without resin cement. **FIGURE 5.** (a) Illustration of the zirconia abutment without resin cement. (b) Resin cement fully adhered to the titanium base. **FIGURE 6.** (a and b) Illustration showing the mixed fracture mode of the resin cement in the zirconia abutment and adhered to the titanium base.

multifunctional methacrylates of phosphoric acid (acidic monomers), silanized silica, calcium hydroxide, titanium dioxide, dimethacrylates, dyes, camphorquinone, and primers for chemical curing.<sup>26</sup> Both cements have similar chemical compositions.

Another factor that may explain the similar performances by both cements would be the curing time allowed prior to the tensile test. A minimum of 48 hours of polymerization was guarded, as deemed suitable for both conventional chemically activated and dual-cure self-adhesive cements.<sup>27</sup> Ferracane<sup>28</sup>

TABLE 3

Absolute and relative frequency (%) of the residual resin cement index after the tensile test				
	Multilink Without Autoclaving (%)	U200 Without Autoclaving (%)	Multilink With Autoclaving (%)	U200 With Autoclaving (%)
Completely adhered to the zirconia abutment	1–10	0–0	0–0	0–0
Completely adhered to the titanium base	0–0	1–10	4–40	4–40
Mixed	9–90	9–90	6–60	6–60

found that after the first 5–10 min of curing, the increase in the degree of conversion (DC) was linear with time over 24 hours; however, such DC increase was not observed for any other resin in 48 hours.

In addition, in the present study, a zirconia primer was used for all 40 abutments to optimize the bond between zirconia and the resin cements,<sup>26</sup> which can also justify the similar performance of the cements before steam autoclave sterilization. Keul et al.<sup>29</sup> reported that ceramic primers in combination with adhesive resin cements demonstrated a positive effect on the shear strength to zirconia and should, therefore, be recommended for cementation.

A significant increase in tensile strength was observed after sterilization for the chemically activated resin cement (Multi-link), thus rejecting the null hypothesis. This result can be explained by the possible increase in the density of crosslinking upon exposure to heat and pressure during autoclaving. The chemically activated cement forms more linear polymer chains than will dual-cure cements, which may have (after sterilization) experienced an increase in crosslinking, favoring higher values of tensile strength.<sup>28,30</sup> In dual-cure cements, light curing triggers a faster polymerization rate, further limiting crosslinking. Additional polymerization methods (such as light, heat, and pressure) have been tested on resin materials and been shown to improve their mechanical characteristics,<sup>31,32</sup> which could explain the findings of the present study.

The residual resin cement index after the tensile test was found to be mostly of the mixed type. This may be related to the internal treatment of the ceramic (primer application for all groups) and sandblasting of the titanium base. However, after sterilization, we observed an increase in bonding failures with the zirconia. This may be due to changes in the physical properties of the cement, resulting in an increase in cohesive strength and consequently greater adhesion to the titanium surface due to sandblasting.

Finally, translating the results from this in vitro study into clinical scenarios, the tensile results were  $465.42 \pm 87,87\text{N}$  for the conventional chemically activated cement and  $289.10 \pm 49,02\text{N}$  for the dual cure self-adhesive cement subjected to steam autoclaving, which, despite the statistical difference, would be sufficient strength in either case to tolerate masticatory loads.<sup>17</sup>

Additionally, it is possible that steam autoclaving could have had a clinically significant impact on the zirconia. In fact, Basilio et al.<sup>33</sup> evaluated the effect of mechanical cycling, steam autoclaving, and thermal cycling on the fracture load, phase stability, and surface microstructure of a Y-TZP abutment. Their results revealed that steam autoclaving was less deleterious

than thermal cycling and mechanical cycling, particularly in terms of fracture resistance of zirconia abutments.<sup>33</sup>

Based on the results of the present study, the feasibility of using either cementation protocols for customized zirconia abutments onto titanium bases was confirmed. This approach would bring functional, biological and esthetic benefits for cases of single-unit implant in highly esthetic areas. Additionally, the sterilization process positively influenced the mechanical properties of the cement, thus adding to the biological benefit of such an approach. Therefore, autoclaving may be used prior to final installation of customized abutments.

## RESULTS

The analysis of variance showed a significant effect of the study factor "cement" ( $P = .0001$ ) and "steam autoclaving" ( $P = .018$ ), and the interaction cement autoclaving ( $P = .04$ ) on the tensile strength. The Tukey test revealed that in the absence of autoclaving, the average tensile strength was not significantly different between the cements ( $P = .314$ ), however, the samples cemented with the conventional chemically activated cement had higher average tensile strength values compared to the dual cure self-adhesive cement when they were subjected to autoclaving ( $P < .001$ ) (Table 2).

Furthermore, autoclaving significantly increased the tensile strength of the samples that used conventional chemically activated cement ( $P = .013$ ). For the dual self-adhesive cement, no influence of autoclaving in the average tensile strength was observed. Regarding the residual resin cement index, Table 3 illustrates that in the nonautoclaved group, most failures were mixed (90%) whereas in the autoclaved group, the majority of the failures were mixed (60%) or fully adhered to the titanium abutment (40%). Figures 4 to 6 illustrate the residual resin cement index.

## CONCLUSION

The results show that steam autoclaving increases the mean tensile strength of the chemically activated cement compared to the dual-cure self-adhesive cement. If the sterilization step was not considered, the performance of both cements evaluated was similar

## ABBREVIATION

Bis-EMA: ethoxylated bisphenol-A dimethacrylate  
Bis-GMA: bisphenol-glycidyl-methacrylate

DC: degree of conversion  
 HEMA: 2-hydroxydoethyl methacrylate  
 UDMA: urethane dimethacrylate

#### NOTE

The authors deny any conflicts of interest related to this study.

#### REFERENCES

- Sailer I, Zembic A, Jung RE, Hämmerle CH, Mattioli A. Single-tooth implant reconstructions: esthetic factors influencing the decision between titanium and zirconia abutments in anterior regions. *Eur J Esthet Dent*. 2007; 2:296–310.
- Andersson B, Ödman P, Lindvall AM, Brånemark P-I. Cemented single crowns on osseointegrated implants after 5 years: results from a prospective study on CeraOne. *Int J Prosthodont*. 1998;11:212–218.
- Jung RE, Sailer I, Hämmerle CHF, Attin T, Schmidlin P. In-vitro color changes of soft tissues caused by restorative materials. *Int J Periodontics Restorative Dent*. 2007;27:251–257.
- Lee A, Fu JH, Wang HL. Soft tissue biotype affects implant success. *Implant Dent*. 2011;20:e38–e47.
- Prestipino V, Ingber A. Esthetic high strength implant abutments. Part I. *J Esthet Dent*. 1993;5:29–36.
- Wohlwend A, Studer S, Schaerer P. The zirconium oxide abutment: a new fully ceramic concept for the aesthetic improvement of the superstructure in implantology [in German]. *Quintessenz Zahntech*. 1996; 22:364–381.
- Kohal RJ, Weng D, Bachle M, Strub JR. Loaded custom-made zirconia and titanium implants show similar osseointegration: an animal experiment. *J Periodontol*. 2004;75:1262–1268.
- Scarano A, Piattelli M, Caputi S, Favero GA, Piattelli A. Bacterial adhesion on commercially pure titanium and zirconium oxide disks: an in vivo human study. *J Periodontol*. 2004;75:292–296.
- Higginbottom F, Belser U, Jones J, Keith S. Prosthetic management of implants in the esthetic zone. *Int J Oral Maxillofac Implants*. 2004; 19(suppl):62–72.
- Stimmelmayer M, Sagerer S, Erdelt K, Beuer F. In vitro fatigue and fracture strength testing of one-piece zirconia implant abutments and zirconia implant abutments connected to titanium cores. *Int J Oral Maxillofac Implants*. 2013;28:488–493.
- Canullo L, Morgia P, Marinotti F. Preliminary laboratory evaluation of bicomponent customized zirconia abutments. *Int J Prosthodont*. 2007;20: 486–488.
- Gehrke P, Alius J, Fischer C, Erdelt KJ, Beuer F. Retentive strength of two-piece CAD/CAM zirconia implant abutments. *Clin Implant Dent Relat Res*. 2014;16:920–925.
- Gehrke P, Johannson D, Fischer C, Stawarczyk B, Beuer F. In vitro fatigue and fracture resistance of one- and two-piece CAD/CAM zirconia implant abutments. *Int J Oral Maxillofac Implants*. 2015;30:546–554.
- Manso AP, Silva NRFA, Bonfante EA, Pegoraro TA, Dias RA, Carvalho RM. Cements and adhesives for all-ceramic restorations. *Dent Clin North Am*. 2011;55:311–332.
- Zorzin J, Belli R, Wagner A, Petschelt A, Lohbauer U. Self-adhesive resin cements: adhesive performance to indirect restorative ceramics. *J Adhes Dent*. 2014;16:541–546.
- Valentino TA, Borges GA, Borges LH, Vishal J, Martins LRM, Correr-Sobrinho L. Dual resin cement Knoop hardness after different activation modes through dental ceramics. *Braz Dent J*. 2010;21:104–110.
- Paphangkorakit J, Osborn JW. The effect of pressure on a maximum incisal bite force in man. *Arch Oral Biol*. 1997;42:11–17.
- Cakan U, Delilbasi C, Er S, Kivanc M. Is it to reuse dental implant healing abutments sterilized and serviced by dealers of dental implant manufacturers? An in vitro sterility analysis. *Implant Dent*. 2015;24:174–179.
- Kern M. Based on scientific evidence, the sterilization of customized implant abutments is required. *Eur J Oral Implantol*. 2015; 8:111.
- Michalakakis KX, Pissiotis AL, Hirayama H. Cement failure loads of 4 provisional luting agents used for the cementation of implant-supported fixed partial dentures. *Int J Oral Maxillofac Implants*. 2000;15:545–549.
- Wahl C, França FMG, Brito Junior RB, Basting R, Smanio H. Assessment of the tensile strength of hexagonal abutments using different cementing agents. *Braz Oral Res*. 2008;22:299–304.
- Baldassarri M, Hjerpe J, Romeo D, Fickl S, Thompson VP, Stappert CF. Marginal accuracy of three implant-ceramic abutment configurations. *Int J Oral Maxillofac Implants*. 2012; 27:537–543.
- Sailer I, Sailer T, Stawarczyk B, Jung RE, Hämmerle CHF. In vitro study of the influence of the type of connection on the fracture load of zirconia abutments with internal and external implant-abutment connections. *Int J Oral Maxillofac Implants*. 2009;24:850–858.
- Blackman R, Barghi N, Duke E. Influence of ceramic thickness on the polymerization of light-cured resin cement. *J Prosthet Dent*. 1990;63:295–300.
- Attia A. Bond strength of three luting agents to zirconia ceramic— influence of surface treatment and thermocycling. *J Appl Oral Sci*. 2011;19: 388–395.
- Kobes KG, Vandewalle KS. Bond strength of resin cements to zirconia conditioned with primers. *Gen Dent*. 2013;61:73–76.
- Vrochari AD, Eliades G, Hellwig E, Wrbas KT. Curing efficiency of four self-etching, self-adhesive resin cements. *Dent Mater*. 2009;25:1104–1108.
- Ferracane JL. Correlation between hardness and degree of conversion during the setting reaction of unfilled dental restorative resins. *Dent Mater*. 1985;1:11–14.
- Keul C, Liebermann A, Ross M, Uhrenbacher J, Stawarczyk B, Ing D. The effect of ceramic primer on shear bond strength of resin composite cement to zirconia: a function of water storage and thermal cycling. *J Am Dent Assoc*. 2013;144:1261–1271.
- Soh MS, Yap AU. Influence of curing modes on crosslink density in polymer structures. *J Dent*. 2004;32:321–326.
- Asmussen E, Peutzfeldt A. Mechanical properties of heat treated restorative resins for use in the inlay/onlay technique. *Scan J Dent Res*. 1990; 98:564–567.
- da Silva GR, Simamoto-Júnior PC, da Mota AS, Soares CJ. Mechanical properties of light-curing composites polymerized with different laboratory photo-curing units. *Dent Mater J*. 2007;26:217–223.
- Basílio MA, Cardoso KV, Antonio SG, Rizkalla AS, Junior GCS, Filho JNA. Effects of artificial aging conditions on yttria-stabilized zirconia implant abutments. *J Prosthetic Dent*. 2016;116:277–285.