

## Oxygen: friend and foe!

Kim H. Hebelstrup  
and Ian M. Møller

(Aarhus University, Denmark)

It is generally believed that the Earth's atmosphere did not contain oxygen until around 2500 million years ago (Mya) when oxygen-evolving photosynthetic bacteria arose. At around 800–500 Mya, the oxygen concentration increased sharply to reach the 21% we have today. So, it seems highly likely that life arose as anaerobic organisms, which then evolved to tolerate oxygen and finally, to use it as a terminal acceptor for the energy-producing oxidative processes in the respiration of aerobic bacteria and mitochondria in eukaryotic cells. The respiratory processes employed by typical aerobic organisms today have a wide range of mechanisms to deal with the troublesome side effects of living with a high oxygen concentration.

**Figure 1.** The respiratory processes in the cytosol and mitochondria of eukaryotic cells. Fermentation, glycolysis and the mitochondrial Krebs cycle with oxidative phosphorylation yield 2 ATP, 5 ATP and 25 ATP per glucose molecule, respectively. Complex I, nicotinamide adenine dinucleotide (NADH) dehydrogenase; Complex III, bc1 complex; Complex IV, cytochrome oxidase; Complex V, ATP synthase; Complex II, succinate dehydrogenase, is not shown.

### Respiration uses oxygen to maximize energy conservation

When people hear the word 'respiration', many will likely associate it with lungs, breathing, blood and perhaps haemoglobin, which function in sequence to absorb oxygen from the air surrounding us and distribute it to all parts of our body.

Readers of *The Biochemist*, with a bit more biochemical knowledge, associate respiration with cells, mitochondria and processes such as the Krebs cycle (aka the tricarboxylic acid cycle or the citric acid cycle), the electron transport chain and the terminal oxidase, cytochrome oxidase, which reduces oxygen to water. The function of these mitochondrial processes is to extract and transiently store the maximum amount of energy from the food we eat.

Food molecules such as carbohydrates are first oxidized to the 3-carbon compound pyruvate via the glycolytic process in the cytosol; however, only about 4% of the available energy is extracted. Pyruvate then enters the mitochondria where it is oxidized all the way to CO<sub>2</sub> in the Krebs cycle (Figure 1).

The electrons extracted from the carbon substrates, in the form of NADH and flavin adenine dinucleotide (FADH<sub>2</sub>), are sent through the respiratory chain in the inner membrane, where four electrons end up reducing O<sub>2</sub> to water. The respiratory chain comprises four multisubunit protein complexes in which a series of redox reactions are coupled to the pumping of protons from the mitochondrial matrix across the inner mitochondrial membrane and into the intermembrane space, creating a transmembrane electrochemical proton gradient. The energy conserved in this gradient is

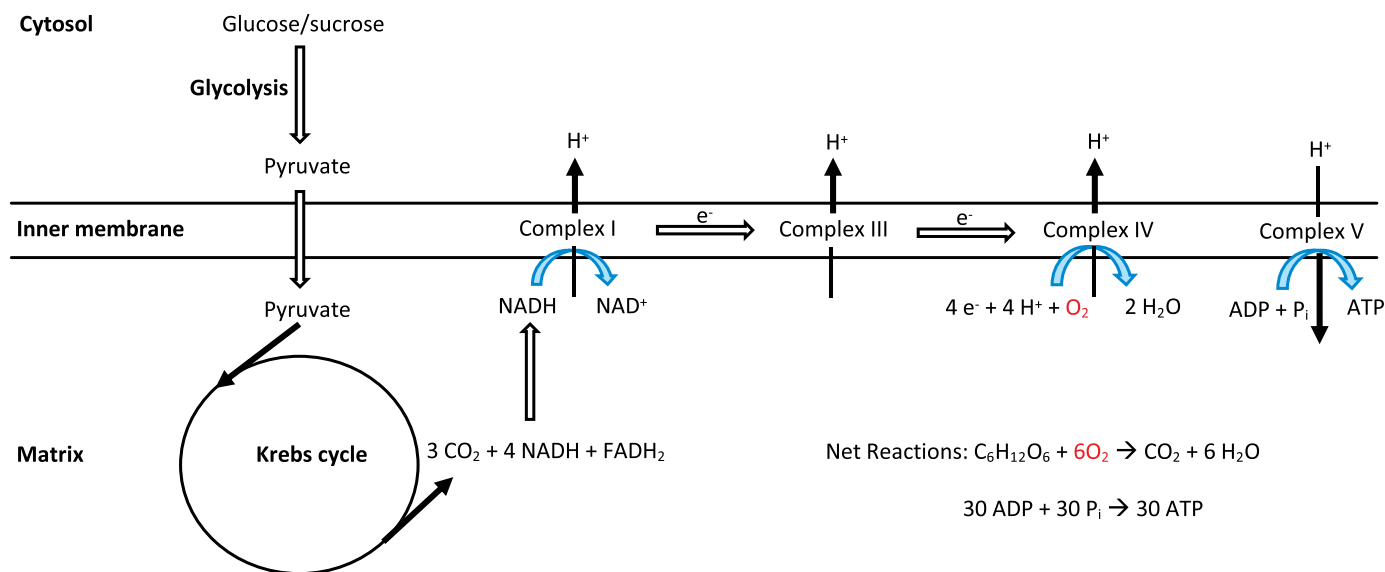

**Figure 2.** Reactive oxygen species (ROS) formation and removal in mitochondria, and the regulatory and damaging processes catalysed by ROS. SOD, superoxide dismutase.

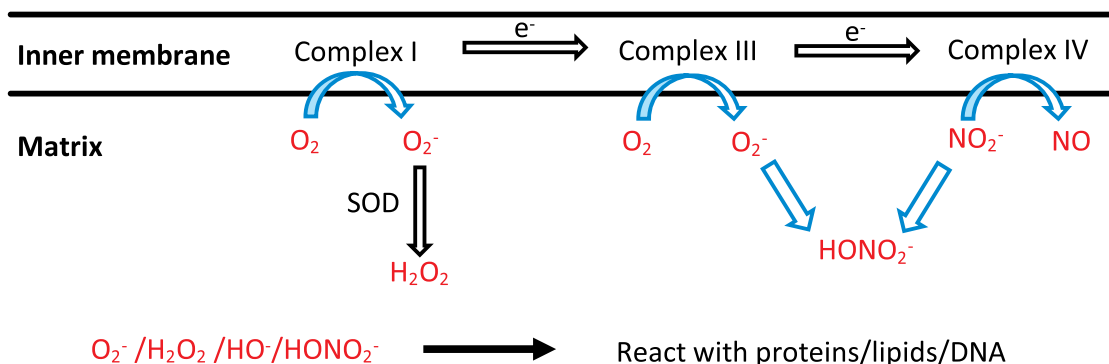

converted into ATP, the main energy currency of the cell [for further information please see the article by Müller and colleagues, page 22], by ATP synthase which is also located in the inner membrane. The energy conservation achieved through oxidative phosphorylation is about 50%, many-fold higher than during glycolysis. The ATP produced is used to energize all the processes in the cells and thus, in our bodies, while the metabolic intermediates in the respiratory processes are used for numerous biosynthetic reactions.

While the physiological processes leading to oxygen distribution in our bodies have evolved specifically in higher animals, the cellular and mitochondrial respiratory processes are essentially the same in all eukaryotes including, perhaps surprisingly, plants. According to the Endosymbiotic Theory (first proposed by Lynn Margulis), these respiratory processes actually evolved in anaerobic bacteria, and mitochondria subsequently arose when an  $\alpha$ -proteo-bacterium was engulfed by another bacterium approximately 1500 million years ago.

At that time, there was no oxygen in the atmosphere and the electron acceptor from the respiratory chain may have been nitrite ( $NO_2^-$ ). The ability to use oxygen as a terminal electron acceptor appeared 800–500 Mya. Even today, plant mitochondria still use nitrite as a terminal electron acceptor under hypoxic conditions, i.e., when little oxygen is present, and one of the products is nitric oxide (NO), which is a hormone in plants just as it is in humans. We will return to consider NO in a moment.

## Respiration produces reactive oxygen species as by-products, which can be problematic

In ordinary aerobic respiration, one molecule of oxygen is reduced to two molecules of water *via* the transfer of four electrons originating in the Krebs cycle (e.g., in the form of NADH) to an oxygen molecule. These final reactions are catalysed by the enzyme complex, cytochrome

oxidase, consisting in mammals of 14 subunits, which tightly binds the partially reduced, and very reactive, oxygen intermediates to prevent their escape.

Sometimes, however, an oxygen molecule interacts with enzymes earlier in the electron transport chain, especially when they are highly reduced, and here it accepts only one electron forming a superoxide anion (Figure 2). This occurs more often under cellular stress conditions (e.g., high temperature or, specifically for plants, high light conditions). The superoxide can be converted into hydrogen peroxide, either spontaneously or in a reaction catalysed by the enzyme Mn-superoxide dismutase (Mn-SOD) found in the mitochondrial matrix. Both superoxide and hydrogen peroxide—so-called reactive oxygen species (ROS)—can readily react with proteins or unsaturated fatty acids and potentially cause damage. Superoxide can also react with NO, if present, to form peroxynitrite, which is probably responsible for many of the ROS- and NO-associated reactions in the cell. An even more serious problem arises if the hydrogen peroxide finds a free metal ion such as  $Fe^{2+}$  or  $Cu^+$ , because they can catalyse the production of hydroxyl radicals ( $HO\cdot$ ) via the Fenton reaction:

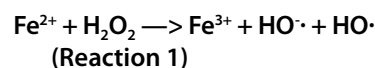

The  $HO\cdot$  formed is extremely reactive with just about everything and is therefore potentially very damaging. To prevent this, mitochondria contain several enzymes to remove/reduce hydrogen peroxide as quickly as possible. As extra insurance, the mitochondria also take care that all metal ions are bound to proteins and unable to catalyse the Fenton reaction.

In spite of these protective mechanisms, reactive oxygen species (ROS) are formed, which can damage proteins, lipids and DNA. The ROS can also act as signalling molecules and initiate cell responses (e.g., activate certain genes) to adjust cellular metabolism to deal with the stress conditions.

## Oxygen-carrying haemoglobin may have developed from an NO-scavenging function

Haemoglobin is well known for its function in the blood of humans and animals as an oxygen carrier. It may therefore be a surprise that haemoglobin also exists in plants, because plants do not have blood or muscles. Haemoglobins in plants are called phytoglobins and are ubiquitous in plant tissues. Plant physiological studies have shown that phytoglobins play essential roles that are distinct from that of carrying, storing and buffering oxygen. Phytoglobins bind oxygen, however their concentration is much too low and their binding affinity for oxygen too high to contribute to a carrying or buffering effect of oxygen in plant tissues. It appears that another chemical mechanism, nitric oxide (NO) dioxygenation, dominates the physiological roles of phytoglobins. The chemical reaction of NO dioxygenation by reduced phytoglobin ( $\text{Pgb}^{2+}$ ) is:

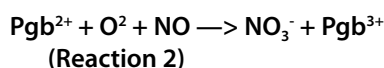

This reaction acts as both an NO-scavenging and NO-fixing mechanism. NO is a significant cellular signalling molecule in plants, and NO scavenging by phytoglobins is an essential mechanism to regulate cellular NO levels. This is important for many plant processes, including organ development, responses to plant pathogens and responses to abiotic stresses. The ability of phytoglobin to fix NO may also contribute to a plant's mineral nutrition; experiments carried out under controlled laboratory conditions have shown that fixation of atmospheric NO can contribute significantly to nitrogen uptake by plants living in soils with low nitrogen content and a high level of NO in the atmosphere. However, the ecophysiological relevance of this mechanism outside the laboratory is still unknown. It does mirror, however, the significant loss of fixed nitrogen that plants experience when they are flooded, thereby creating hypoxic conditions leading to the conversion of nitrite to NO, which is released from the plants.

Haemoglobins in plants were first identified in the 1920s by the Japanese scientist Hideo Kubo. He found these haemoglobins only in very specialized plants belonging to the legume family, which includes

**Figure 3.** Evolutionary history of haemoglobin function in plants and animals.

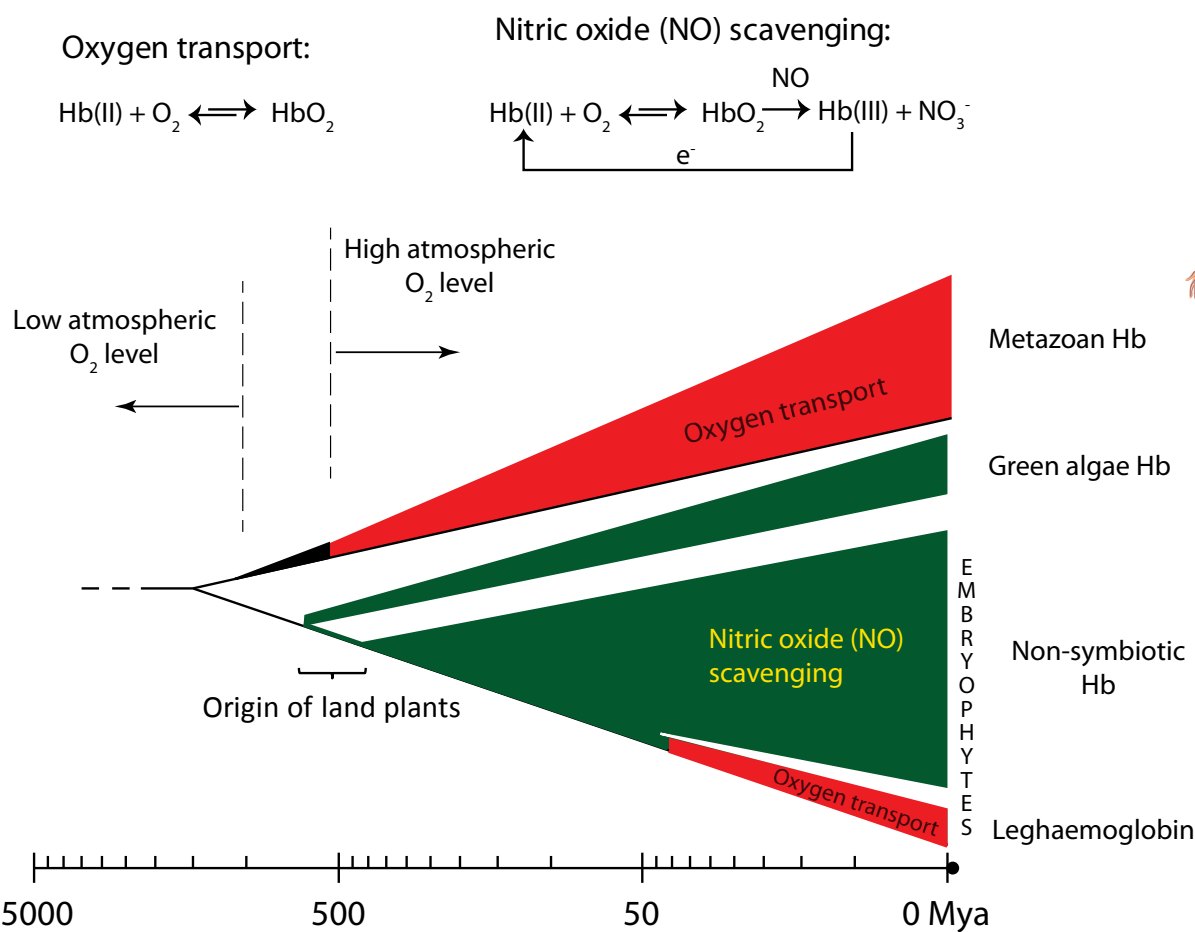

species such as pea and soybean. These plants develop root nodules containing symbiotic bacteria that have the important role of fixing atmospheric  $N_2$ , which the host plant can use. [As is described in more detail in the article by Cocking and Dent, page 14]. The bacteria and the enzymes performing this process are essentially obligate anaerobes, but they live inside plant cells performing ordinary aerobic metabolism. Kubo found haemoglobin at high concentrations inside the legumes' symbiotic root nodules and called them leghaemoglobins. The primary role of leghaemoglobin in root nodules is to bind and buffer  $O_2$  to protect the symbiotic bacteria. In contrast to phytohemoglobin, which is found ubiquitously in all plants, leghaemoglobins are limited to plants with the ability to form symbiotic root nodules. Evolutionary studies show that the symbiotic relationship with nitrogen-fixing bacteria in legumes is less than 50 Mya. This suggests that the protective role of binding and buffering oxygen by leghaemoglobins is an evolutionary specialization that emerged only in the few plant species capable of developing symbiotic root nodules (Figure 3). It is possible that NO scavenging was the original role of haemoglobins in the cellular lineage that led to the evolution of animals and humans. Interestingly, humans and other mammals also have non-oxygen-carrying haemoglobins, expressed for instance in nerve tissues, and they probably have a role in regulating the tissue level of NO just like in plants. ■

## Further reading

- Great oxygen event. Accessed 30/05/2019: [https://en.wikipedia.org/wiki/Great\\_Oxygenation\\_Event](https://en.wikipedia.org/wiki/Great_Oxygenation_Event)
- Halliwell, B. and Gutteridge, J.M.C. (2015) *Free Radicals in Biology & Medicine*. 5th Ed., Oxford University Press, Oxford, UK
- Nicholls, D.G. and Ferguson, S.J. (2013) *Bioenergetics 4*. Academic Press, Amsterdam, The Netherlands
- Degli Esposti, M., Mentel, M., Martin, W. and Filipa L. Sousa, F.L. (2019) Oxygen reductases in Alphaproteobacterial genomes: physiological evolution from low to high oxygen environments. *Front. in Microbiol.* **10**, Article 499
- Hebelstrup, K.H. and Møller, I.M. (2015) Mitochondrial signaling in plants under hypoxia: use of reactive oxygen species (ROS) and reactive nitrogen species (RNS). In *Reactive Oxygen and Nitrogen Species Signaling and Communication in Plants* (K.J. Gupta and A.U. Igamberdiev, eds), pp. 63–77, Springer



*Kim H. Hebelstrup obtained his PhD from Aarhus University in Denmark working on haemoglobin in plants. He then spent two years in the laboratory of Professor Robert D. Hill in Winnipeg, Manitoba, Canada, before returning to Aarhus University where he is now Associate Professor in the Department of Molecular Biology and Genetics. His present research interests are two-fold: (i) The role of haemoglobins in NO turnover in plants and its significance for plant adaptation to stress. (ii) Unravelling starch metabolism and finding ways of producing modified starch with tailor-made properties. Email: [kim.hebelstrup@mbg.au.dk](mailto:kim.hebelstrup@mbg.au.dk)*



*Ian Max Møller obtained his PhD in plant biochemistry at Imperial College, London, UK. From there he moved to Lund University, Sweden, where he worked for 20 years before returning to his native Denmark. He is now Professor Emeritus at the Department of Molecular Biology and Genetics at Aarhus University. One of his present interests is trying to understand the regulation of plant respiration at the molecular level. This involves using proteomics and related techniques to study the formation of reactive oxygen species, their reactions with mitochondrial proteins and the effect this has on the structure and function of the proteins and ultimately on respiration. Email: [ian.max.moller@mbg.au.dk](mailto:ian.max.moller@mbg.au.dk)*