

Wear Resistance and Hardness Assessment of Five US Hardwoods for Bridge Decking and Truck Flooring*

Laya Khademibami Rubin Shmulsky Dusty Snow
 Alan Sherrington Iris Montague Robert J. Ross Xiping Wang

Abstract

The wear resistance and Janka hardness of five United States hardwood species were evaluated for potential use in bridge decking and truck flooring. The species tested include ash (*Fraxinus* sp.), hickory (*Carya* sp.), red oak (*Quercus* sp.), sweetgum (*Liquidambar styraciflua*), and white oak (*Quercus* sp.). The specimens were prepared with the sizes of 1 by 2 by 4 inches (2.54 by 5.08 by 10.16cm) for abrasion test and 1 by 2 by 6 inches (2.54 by 5.08 by 15.24 cm) for Janka hardness testing. The specimens were cut from 30 individual parent boards of random width with clear sections for each species. The abrasion and Janka hardness tests were performed according to the American Society of Testing and Materials standards. All wear and hardness data were statistically analyzed by 1-way analysis of variance. The results of this study demonstrated that sweetgum with the lowest density had the greatest amount of thicknesses loss and thus lowest wear resistance. White oak was found to have the least thicknesses loss, thus highest wear resistance among the hardwood species tested. Hickory, with the highest density, had the highest hardness among the hardwood species tested, but it had relatively lower wear resistance comparing to ash, red oak, and white oak.

In many applications, wear resistance and hardness are tremendously important properties of wood and wood products. Wear resistance plays a crucial role in applications where high-volume foot or vehicular traffic in structures is observed, such as in the transportation industry for decking and in structures for bridges. Wear resistance and hardness tests are two methods that have been used extensively for measuring the resistance of wood floorings and other wood-based panel materials. Wear refers to the loss of material from the surface of a material by the mechanical process of rubbing the surface with abrasives. Abrasion is one of the actions that can cause wear. Wear and abrasion are often considered to be the same. Hardness is useful to determine directly how well a wood species withstands dents and

dings, and to predict the resistance of a wood species in nailing, screwing, sanding, and sawing. These features (wear resistance and hardness) are primarily affected by wood density, temperature, and moisture (Janka 1906, V. Lorenz 1909, Ncube 2008). To some degree, wood anatomy is important as well, particularly in ring-porous hardwood where the specific gravity (SG) differences between earlywood (springwood) and latewood (summerwood) can be very large.

The direct relationship of wear resistance to relative density was reported by Franz and Hinken (1954). In their work specifically related to machining wood with abrasives, the scientists found that the relationship of woody fiber removed abrasively appeared to be associated to a large

The authors are, respectively, Postdoctoral Associate (lk475@mssatte.edu), Department Head and Warren S. Thompson Professor (rs26@msstate.edu), and Graduate Students (rds45@msstate.edu [corresponding author], ajs1189@msstate.edu), Department of Sustainable Bioproducts, Mississippi State University, Mississippi State; Research Forester, USDA Forest Service, Northern Research Station, Starkville, Mississippi (iris.b.montague@usda.gov); and Supervisory Research Gen. Engineer (Robert.j.ross@usda.gov) and Research Forest Products Technologist (Xiping.wang@usda.gov), USDA Forest Service Forest Products Laboratory, Madison, Wisconsin. This paper was received for publication in December 2021. Article no. 21-00074.

* This article is part of a series of selected articles addressing a theme of bringing academia, industry, and government entities together to work on innovation and applied technologies. The research reported in these articles was presented at the PTF BPI Conference, held on November 1–3, 2021, in St. Simons Island, Georgia. All articles are published in this issue of the Forest Products Journal.

©Forest Products Society 2022.

Forest Prod. J. 72(S1):8–13.

doi:10.13073/FPJ-D-21-00074

extent with species' density, as resistance to indentation is dependent primarily on this factor. In their work, less dense species were abraded more quickly. According to their research, relative wood density influenced, to the greatest degree, the extent of the penetration of the grit (abrasive) particles. The research also showed that wood at 12 percent moisture content (MC) abraded more quickly than that at 6 percent. In other research, a series of 20 species was rated based on their tendency to create "fuzz" (short bits of wood fiber that are attached to the board at one end and are free at the other) during sanding (Davis 1962). White oak, red oak, ash, and hickory were among the top five performers among woods that are currently available commercially. Experimentally, it was discovered that hardness is approximately proportional to the SG of wood (Janka 1906, v. Lorenz 1909). Kollmann and Cote (1968) reported on a series of research related to SG, hardness, and abrasion resistance. Newlin and Wilson (1919) experimentally discovered and reported a relationship between Janka hardness and SG. Janka (1906) and Janka and Hadek (1908 and 1915) proposed a modified Brinell hardness test for wood. In those works, the force required to completely embed a 0.444-inch-diameter (11.3-mm-diameter) steel hemisphere (which corresponds to 2 cm² of surface area) into the specimen was determined. Janka tests have been standardized wherein they are conducted on sides and end of the specimen, with no distinction made for radial or tangential orientation (ASTM D143-14 [ASTM 2017b]).

A simple abrasion test that indicates the wear resistance of wood species would be of great value. In the 1940s, the US Forest Products Laboratory developed and evaluated the Navy wear-test machine for its feasibility in accessing the wear resistance of wood (Youngquist and Munthe 1948). The purpose of that work was to evaluate teak (*Tectona grandis*) and other wood species for use as decking on naval ships. That work resulted in the wear-resistance test and wear-resistance data for several species, currently listed in ASTM D2394-17 (ASTM 2017a). The results obtained from this wear-test machine support comparison and evaluation between new flooring materials and the wood species commonly used for flooring.

In this study, the wear resistance and hardness of five hardwood species (ash, hickory, red oak, sweetgum, and white oak) were evaluated for potential use in high-wear environments such as bridge decking and trailer flooring. Trailer and truck decking and flooring need to have appropriate levels of abrasion resistance, compression strength, biological durability, and flexural strength. Apitong (*Dipterocarpus* sp.), which is an imported tropical hardwood, can meet these property requirements. It has appropriate strength, high resistance to abrasion and decay, heavy thicknesses, and particularly clear pieces (Gerry 1952). The US military has been using apitong as flooring for its tactical trailers for several decades. However, this wood has become increasingly rare and many of its subspecies are critically endangered, making it unavailable for future use. Therefore, finding sustainable alternative materials has become a critical need. Among currently available options, US hardwoods offer the greatest potential for a sustainable and cost-effective material that can perform well in a wide range of environmental conditions. Therefore, the objective of this study was to evaluate the wear and surface hardness characteristics of five US hardwood species and rank the species for their suitability

for bridge decking and trailer flooring applications. Based on previous research (Carmona et al. 2020 a, 2020b; Franca et al. 2021; Shmulsky et al. 2021), the authors did not suspect that these properties had changed over time; however, not all species have been previously investigated and these particular properties are not frequently investigated or reported.

Materials and Methods

Specimen preparation

Five species of hardwoods were selected for abrasion (also known as "wear") and hardness tests. These five species were ash, hickory, red oak, sweetgum, and white oak. For each species, approximately 350 board feet (0.83 m³) of random width, 1-inch-thick (2.5-cm-thick), variable grade rough lumber was procured. Both kiln-dried (ash, hickory, and sweetgum) and green lumber (red and white oak) were received. The green lumber was air-dried to approximately 12 to 15 percent MC prior to processing. From the parent packs of lumber, approximately 30 individual parent boards were then selected from each group. By selecting material in this manner, each test specimen came from a unique parent board thereby capturing as much variability as possible. A clear section approximately 30 inches (76 cm) long was then removed from each parent board. From this section, test specimens were prepared. For preparation, first the 30-inch-long (76-cm) sections were skim planed on two faces and jointed along one edge. The sections were then ripped to yield 2-inch-wide (5-cm) clear strips. After the strips were ripped, a 6-inch-long (15.24-cm) hardness specimen was cut from each. This action resulted in a hardness specimen approximately 1 by 2 by 6 inches³ (2.54 by 5 by 15.24 cm³). Next, the remaining 24-inch-long (61-cm) strips were replaned to 0.75-inch (1.90-cm) thickness. Clear 4-inch-long (10.16-cm) abrasion specimens were then cut from the 0.75-inch thick, 2-inch-wide (1.90 by 5-cm) strips. Abrasion specimens were then prepared per ASTM D2394-17 (ASTM 2017a) wherein 0.5-inch-wide (1.27-cm) rabbet cuts were made into the ends of the specimens to facilitate mounting on the abrasion tester (Fig. 1). This action left a 2 by 3-inch (5 by 7.62-cm) face to be abraded. Next, 4-inch-long (10.16-cm) MC and SG specimens were cut from the strips. Each MC/SG specimen was thus approximately 0.75 by 2 by 4 inches³ (1.90 by 5 by 10.16 cm³). All specimens (abrasion, hardness, MC, and SG) were then acclimated in a 12 percent MC environmental chamber at 70°F (21°C) and 65 percent relative humidity for a minimum of 2 weeks. Wear and hardness tests were done with random or noncontrolled orientation with respect to tangential and radial directions. In this manner, it was anticipated that the variation of both orientations, combined, was captured.

Abrasion test

Following MC acclimation, abrasion specimens were tested on a navy-type wear tester according to ASTM D2394-17 (ASTM 2017a; Fig. 2). Briefly, for this testing, each specimen was mounted on a plate that rotated at 32 ½ revolutions per minute (RPM) with a 10-pound (4.5-kg) weight mounted above and thereby applying downward pressure. This mounting plate was elevated off and then immediately returned to the abrading plate, via cam followers, 1/16 inch (1.6 mm) twice per rotation. The

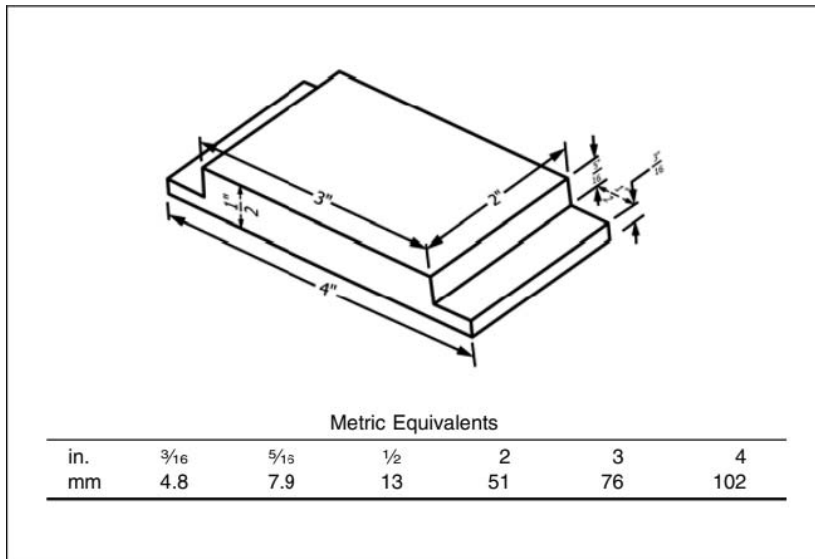

Figure 1.—ASTM2394-17 standard test specimen for abrasion resistance of finish flooring.

abrading plate rotated in the same direction as the specimen mounting plate at a rate of 23 1/2 RPM. The abrading plate had a constant flow of new 80 grit aluminum oxide media applied for the duration of the test. Specimen thickness was measured at five locations (i.e., the four corners and the center) before testing and then at 100-rotation intervals for the duration of the test. This process was repeated until each

specimen had undergone 500 rotations. In Figure 2, the machine has guards installed over its gear and chain works. One of the clamps used to affix the specimen to the mounting plate is shown in the forefront. The fixture that holds the 10-pound weight and mounts at the top of the shaft to which the specimen becomes affixed has been removed and is not shown.

Hardness test

Hardness specimens were tested according to ASTM D143-14 (ASTM 2017b). This test was performed by penetrating the surface of the specimen with a 0.444 in diameter (11.3-mm-diameter) steel ball to a depth of 0.222 inches (5.63 mm) at a rate of 0.25 inches per minute (6.35 mm per minute). The specimens in this study were tested once on each end and once on each wide face, for a total of 4 penetrations per specimen. The average force required for the two end penetrations was used for analysis of end hardness. The average force required for the two wide face penetrations was used for analysis of face hardness.

Moisture content, density, and SG measurements

The MC and SG specimens were tested in accordance with ASTM D4442-16 Method A (ASTM 2017d) and ASTM D2395 (ASTM 2017c). Following MC acclimation in the 12 percent MC environmental chamber, the specimens were weighed with a balance that was accurate to 0.1 g and volume measured with a digital caliper. Each specimen was then dried in an oven at 103 ± 3°C (217.4 ± 5.4°F) for 48 hours and then weighed and measured in the same manner as before. The MC, density, and SG were measured according to the following formulas (1, 2, and 3).

$$MC = \frac{W_{in} - W_{od}}{W_{od}} \times 100 \quad (1)$$

where MC is moisture content (%), W_{in} is initial weight (g), and W_{od} is oven-dried weight (g);



Figure 2.—Navy-type wear tester used to conduct abrasion test.

Table 1.—Moisture content (% dry basis), density, and specific gravity of five hardwood species at the time of testing.

	Ash				Hickory				Red oak				Sweetgum				White Oak			
	Density				Density				Density				Density				Density			
	MC (%)	(g/cm ³)	(lb/in ³)	Specific gravity	MC (%)	(g/cm ³)	(lb/in ³)	Specific gravity	MC (%)	(g/cm ³)	(lb/in ³)	Specific gravity	MC (%)	(g/cm ³)	(lb/in ³)	Specific gravity	MC (%)	(g/cm ³)	(lb/in ³)	Specific gravity
Mean	12.8	0.682	0.025	0.61	13.1	0.801	0.029	0.71	15.3	0.731	0.026	0.63	12.4	0.602	0.022	0.54	16	0.760	0.027	0.65
SD	4.47	0.059	0.002	0.05	0.43	0.082	0.003	0.07	0.85	0.050	0.002	0.04	1.02	0.059	0.002	0.05	0.71	0.057	0.002	0.04
Min	11.1	0.521	0.019	0.47	12.5	0.632	0.023	0.56	13.5	0.614	0.022	0.54	9.9	0.504	0.018	0.45	14.9	0.670	0.024	0.59
Max	14.4	0.766	0.028	0.68	14.4	0.945	0.034	0.84	16.7	0.817	0.030	0.7	16.6	0.790	0.029	0.68	17.9	0.876	0.032	0.74

Table 2.—Summary statistics for abrasion test of five hardwood species, with 30 replicates per species. Results are shown as thickness loss based on 500 revolutions of the abrading disk.

	Δ Thickness									
	Ash		Hickory		Red oak		Sweetgum		White oak	
	mm	in.	mm	in.	mm	in.	mm	in.	mm	in.
Mean	0.1850	0.0073	0.2120	0.0084	0.1750	0.0069	0.2340	0.0092	0.1470	0.0058
Median	0.1870	0.0073	0.2080	0.0082	0.1660	0.0065	0.2260	0.0089	0.1440	0.0057
SD	0.0450	0.0018	0.0560	0.0022	0.0430	0.0017	0.1000	0.0039	0.0340	0.0013
COV (%) ^a	24.2	24.2	26.4	26.2	24.8	24.8	42.6	42.6	23.2	23.2
Min	0.0740	0.0029	0.0980	0.0039	0.1070	0.0042	0.1140	0.0045	0.0740	0.0029
Max	0.2840	0.0112	0.3430	0.0135	0.2640	0.0104	0.6780	0.0267	0.2290	0.0090

^aCOV = coefficient of variation.

$$\text{Density} = \frac{W_{in}}{V_{in}} \quad (2)$$

where density is g/cm³, W_{in} is initial weight (g), and V_{in} is initial volume (cm³); and

$$\text{SG} = \frac{W_{od}}{V_{in}} / 1\text{g/cm}^3 \quad (3)$$

where SG is specific gravity, W_{od} is oven-dried weight (g), and V_{in} is initial volume (cm³).

Statistical analysis

The experimental design was completely randomized. All abrasion and hardness data were analyzed by 1-way analysis of variance (ANOVA) using the procedure for general linear mixed models (PROC GLIMMIX) of SAS 9.4 (SAS Institute, 2013). Differences were considered significant with a *P* value less than or equal to 0.05. Summary statistics for abrasion and hardness are all reported. Additionally, the statistical model represented by 1-way ANOVA is $Y_i = \mu + T_i + E_i$, where μ is the population mean, T_i is the effect of different species ($T = 1$ to 5), and E_i is the residual error.

Results and Discussion

The statistical summaries for MC as percent dry basis, density, and SG are shown in Table 1. According to the results, all specimens had a MC between 12 and 16 percent at the time of testing. Among all five hardwood species, hickory had the highest density (0.029 lb/in³ or 0.80 g/cm³) and SG (0.71), and sweet gum had the lowest density (0.022 lb/in³ or 0.602 g/cm³) and SG (0.54); white oak, red oak and ash fell between.

The abrasion summary statistics are illustrated in Table 2 as the thickness loss based on 500 revolutions of the

abrading disk. Among all five species tested, sweetgum, with the lowest density, had the most amount of wear (0.0092 in or 0.234 mm in thickness loss), which is expected and consistent with previous reports (Youngquist and Munthe 1948, Franz and Hinken 1954). It means that pieces with lower density and higher MC are abraded more quickly. However, hickory, with the highest density, did not yield the least amount of wear as we would expect; instead, it had a thickness loss of (0.0084 in or 0.212 mm), second highest among the five species tested. White oak, on the other hand, was found to have the least amount of wear (0.0058 in or 0.147 mm in thickness loss), indicating highest abrasion resistance. Table 3 shows the relative order of the abrasion resistance of five hardwood species, from the most amount of wear to least amount of wear: sweetgum, hickory, ash, red oak, and white oak. According to the statistical ANOVA results, there were statistically significant differences in thickness loss ($P < 0.0001$) among all five hardwood species (Table 3). The abrasion test data of

Table 3.—Abrasion test values of five hardwood species along with *P* value levels of significance as well as mean separations (Materials with the same letter were not statistically different from each other at the alpha = 0.05 level of significance).

Material	Δ Thickness		Mean separation
	mm	in.	
Sweetgum	0.234	0.0092	A
Hickory	0.212	0.0084	AB
Ash	0.185	0.0073	BC
Red oak	0.175	0.0069	DC
White oak	0.147	0.0058	D
SEM	0.0155	0.00061	
<i>P</i> value	<0.0001	<0.0001	

Table 4.—Summary statistics for face and end hardness of five hardwood species. The number of replicates for each species was 30. Each specimen was tested once on each wide face and end, and the average of the two test measurements was used as the value for the specimen.

	Ash						Hickory						Red oak						Sweetgum						White oak					
	Face hardness		End hardness		Face hardness		End hardness		Face hardness		End hardness		Face hardness		End hardness		Face hardness		End hardness		Face hardness		End hardness		Face hardness		End hardness			
	N	lbf	N	lbf	N	lbf	N	lbf	N	lbf	N	lbf	N	lbf	N	lbf	N	lbf	N	lbf	N	lbf	N	lbf	N	lbf	N	lbf		
Mean	6628	1490	7574	1703	9031	2030	8986	2020	5874	1321	6550	1472	4345	976.72	5886	1323	6064	1363	6549	1472	6064	1363	6549	1472	6064	1363	6549	1472		
Median	6755	1519	7594	1707	9322	2096	9325	2096	5729	1288	6565	1476	4214	947.43	5792	1302	5963	1341	6449	1450	5963	1341	6449	1450	5963	1341	6449	1450		
SD	1209	272	885	199	2254	507	1390	313	1008	227	667	150	1028	231.06	1004	226	993	223	723	163	993	223	723	163	993	223	723	163		
COV (%) ^a	18	18	11.68	11.68	24.96	24.96	15.47	15.47	17.16	17.16	10.18	10.18	23.70	23.66	17.06	17.06	16.38	16.38	11.05	11.05	16.38	16.38	11.05	11.05	16.38	16.38	11.05	11.05		
Min	4078	917	5049	1135	4087	919	5834	1312	4142	931	5456	1227	2672	600.60	3621	814	4207	946	5158	1160	4207	946	5158	1160	4207	946	5158	1160		
Max	9261	2082	9426	2119	13647	3068	11863	2667	8194	1842	8235	1851	7488	1683	9080	2041	8360	1879	8244	1853	8360	1879	8244	1853	8360	1879	8244	1853		

^aCOV = coefficient of variation.

this study indicated that no definite relationship exists between abrasion resistance and wood density within the hardwood species tested. The other observation we made in this study is that the abrasion test data of sweetgum exhibited a coefficient of variation of 42.6 percent, much higher than other species (23.2% to 26.2%). We are not clear about what caused this unusually high variation in wear resistance in sweetgum, but the growth characteristics or structure variation may be a contributing factor.

Summary statistics of Janka hardness test results (both face and end hardness) are also demonstrated in Table 4. The ANOVA results of Janka hardness showed that there were statistically significant differences in both face and end hardness ($P < 0.0001$) among all five hardwood species tested (Tables 5 and 6). The SG has the most effective impact on the hardness of wood species (Panshin and de Zeeuw 1980). It is well documented that there is a linear relationship between hardness and density (Ylinen 1943, Miyajima 1963, Kollmann and Cote 1968, Holmberg 2000). The results of Janka hardness and SG tests in the current research proved that there is a direct relation between hardness and SG. Hickory, with the highest SG, had the highest level of hardness in both face and end with the values of 2030 lbf and 2020 lbf (9,031 and 8,986 N) while sweet gum, with the lowest SG, had the lowest hardness in both face and end with the values of 976.72 lbf and 1323 lbf (4,345 and 5,886 N). Ash, red oak, and white oak had the moderate face and end Janka hardness results that were close to one another.

Table 5.—Mean face hardness values of five hardwood species along with P value levels of significance as well as mean separations (Materials with the same letter were not statistically different from each other at the alpha = 0.05 level of significance).

Material	Face hardness		Mean separation
	N	lbf	
Hickory	9,031	2030	A
Ash	6,628	1490	B
White oak	6,064	1363	C
Red oak	5,874	1321	C
Sweetgum	4,345	977	D
SEM	253	56.87	
P value (alpha = 0.05)	<0.0001	<0.0001	

Table 6.—Mean end hardness values of five hardwood species along with P value levels of significance as well as mean separations (Materials with the same letter were not statistically different from each other at the alpha = 0.05 level of significance).

Material	End hardness		Mean separation
	N	lbf	
Hickory	8,986	2020	A
Ash	7,574	1703	B
Red oak	6,550	1472	C
White oak	6,549	1472	C
Sweetgum	5,886	1323	D
SEM	177	28.11	
P value (alpha = 0.05)	<0.0001	<0.0001	

Conclusion

Investigation of the abrasion resistance and Janka hardness of five US hardwood species indicated that white oak had the least thicknesses loss, thus highest wear resistance among the five hardwood species tested. It is surmised that white oak's higher density, as compared to red oak, accounted for its superior performance. Sweetgum, with the lowest density, had the greatest thicknesses loss and thus lowest wear resistance. Though not compared statistically, the side/face hardness results for these species appear similar to or greater than those presented in the *Wood Handbook* (Forest Products Laboratory 2010). Hickory, with the highest density, had the highest hardness among the hardwood species tested, but it had relative higher thickness loss, thus lower wear resistance comparing to ash, red oak, and white oak. Hickory, with the highest SG and acceptable changes in thickness loss, had the best abrasion resistance. Hickory can be a potential candidate for use in the trailer flooring and truck decking.

Acknowledgments

This publication is a contribution of the Forest and Wildlife Research Center, Mississippi State University. This study was conducted through a cooperative research agreement (FS 20-JV-11111133-032) between Mississippi State University and USDA Forest Service, Forest Products Laboratory, and partially funded by USDA Forest Service, Forest Products Laboratory. The authors also acknowledge the US Endowment for Forests and Communities for its contributions to this research.

Literature Cited

- American Society of Testing and Materials (ASTM). 2017a. Standard test methods for simulated service testing of wood and wood-based finish flooring. ASTM D2394-17. ASTM International, West Conshohocken, Pennsylvania.
- American Society of Testing and Materials (ASTM). 2017b. Standard test methods for small clear specimens of timber. ASTM D143-14. ASTM International, West Conshohocken, Pennsylvania.
- American Society of Testing and Materials (ASTM). 2017c. Standard test methods for density and specific gravity (relative density) of wood and wood-based materials. ASTM D2395-17. ASTM International, West Conshohocken, Pennsylvania.
- American Society of Testing and Materials (ASTM). 2017d. Standard tests methods for direct moisture content measurement of wood and wood-based materials. ASTM D4442-16. ASTM International, West Conshohocken, Pennsylvania.
- Carmona, M. G., R. D. Seal, and F. G. N. Franca. 2020a. Physical and mechanical properties of hard maple (*Acer saccharum*) and yellow poplar (*Liriodendron tulipifera*). Forest Products J. 70(3):326–334.
- Carmona, M. G., R. D. Seal, and F. G. N. Franca. 2020b. Physical and mechanical properties of clear wood from red oak and white oak. Bioresources J. 15(3):4960–4971.
- Davis, E. M. 1962. Machining and related characteristics of United States hardwoods. Technical Bulletin No. 1267. USDA Forest Service, Washington, D.C. 68 pp.
- Forest Products Laboratory. 2010. Wood handbook: Wood as an engineering material. General Technical Report FPL-GTR-190. USDA Forest Service, Forest Products Laboratory, Madison, Wisconsin. Table 5.3a.
- Franca, F. J. N., R. Shmulsky, J. T. Ratcliff, B. Farber, C. A. Senalik, R. J. Ross, and R. D. Seale. 2021. Yellow pine small clear flexural properties across five decades. Forest Products J. 71(3):233–239.
- Franz, N. C. and E. W. Hinken. 1954. Machining wood with coated abrasives. J. Forest Prod. Res. Soc. 4(5):251–254.
- Gerry, E. 1952. Foreign woods: Apitong. Report No. R1920. USDA Forest Service, Forest Products Laboratory, Madison, Wisconsin.
- Holmberg, H. 2000. Influence of grain angle on Brinell hardness of Scots pine (*Pinus sylvestris* L.). Holz Roh Werkst 58:91–95.
- Janka, G. 1906. Cbl. Ges. Forstwes. 9 pp. 193, 241. In: Kollmann Principles of Wood Science and Technology, Springer, New York, 1984.
- Janka, G. and A. Hadek. 1908. Über Holz ärteprüfung. Cbl. Ges. Forstwes. 11:443.
- Janka, G. and A. A.Hadek, 1915. Die Härte der Hölzer. Mitt. Forstl. Versuchswes. Vienna, Austria.
- Kollmann, F. F. P. and W. A. Cote. 1968. Principles of Wood Science and Technology. I. Solid Wood. Springer-Verlag, Heidelberg, Germany. pp. 403–412.
- Miyajima, H. 1963. Studies in the indentation hardness of wood. Res Bull Hokkaido Univ. 22(2):539–607.
- Ncube, E. 2008. Use of a simple abrasive-wear resistance test device to assess the suitability of selected hardwoods for wood flooring. Sci. Res. Essay 3(5):168–173.
- Newlin, J. A. and T. R. C. Wilson. 1919. The relation of the shrinkage and strength properties of wood to its specific gravity. USDA Bulletin No. 676. USDA, Washington, D.C.
- Panshin, A. J. and C. de Zeeuw. 1980. Textbook of Wood Technology: Structure, Identification, Properties, and Uses of the Commercial Woods of the United States and Canada. McGraw-Hill, New York. 736 pp.
- SAS Institute. 2013. User Guide: Statistics (Release 9.4). SAS Institute, Cary, North Carolina.
- Shmulsky, R., F. J. N. Franca, J. T. Ratcliff, B. Farber, C. A. Senalik, R. J. Ross, and R. D. Seale. 2021. Compression properties of small clear southern yellow pine specimens tested across five decades. Forest Products J. 71(3):240–245.
- V. M.Lorenz, 1909. Analytische untersuchung des begriffs der holzharte. Mitt. Forstl. ersuchswes. Vienna, Austria. p. 33.
- Ylinen, A. 1943. Ü ber den Einfluß der Rohwichte und des Spätholzanteils auf die Brinellhärte des Holzes. Holz Roh Werkst 6(4):125–127.
- Youngquist, W. G. and B. P. Munthe. 1948. The abrasive resistance of wood as determined with the U.S. Navy wear-test machine. Report No. R1732. USDA Forest Service, Forest Products Laboratory, Madison, Wisconsin.