

Why People Are Always Thinking about Themselves: Medial Prefrontal Cortex Activity during Rest Primes Self-referential Processing

Meghan L. Meyer¹ and Matthew D. Lieberman²

Abstract

■ Humans have a tendency to think about themselves. What generates this self-focus? One clue may come from the observation that the same part of the brain that supports self-reflection—the medial pFC (MPFC/Brodmann’s area 10 [BA 10])—also spontaneously engages by default whenever the brain is free from external demands to attention. Here, we test the possibility that the default tendency to engage MPFC/BA 10 primes self-referential thinking. Participants underwent fMRI while alternating between brief pe-

riods of rest and experimental tasks in which they thought about their own traits, another person’s traits, or another location’s traits. Greater default engagement in MPFC/BA 10 during momentary breaks preferentially facilitated task performance on subsequent self-reflection trials on a moment-to-moment basis. These results suggest that reflexively engaging MPFC/BA 10 by default may nudge self-referential thinking, perhaps explaining why humans think about themselves so readily. ■

INTRODUCTION

Humans seem to be predisposed to think about themselves. We discuss ourselves at length during communication (Naaman, Boase, & Lai, 2010; Dunbar, Marriott, & Duncan, 1997); project our personal beliefs, traits, and experiences onto others during attribution (Tamir & Mitchell, 2013; Epley, Keysar, Van Boven, & Gilovich, 2004); and are more likely to remember information if it is personally relevant (Symons & Johnson, 1997; Bower & Gilligan, 1979). Given the primacy of the self in everyday experience, a great deal of psychological research has been devoted to understanding self-processes. For example, researchers have examined the content and organization of self-concepts (McConnell, 2011; Markus & Kunda, 1986; Linville, 1985; Markus, 1977), as well as how people evaluate themselves to create self-esteem (Crocker & Knight, 2005; Leary & Baumeister, 2000). Although this work has been pivotal to understanding the self, the mechanism that biases people toward self-referential processing remains unexplored. In other words, why are people so inclined to think about themselves?

Two observations from neuroscience may provide insight into why people tend to think about themselves so readily. First, self-referential processing activates cortical midline structures, particularly medial pFC (MPFC)/Brodmann’s area 10 (BA 10; Denny, Kober, Wager, & Ochsner, 2012; Ochsner et al., 2004; Fossati et al., 2003; Johnson et al., 2002; Kelley et al., 2002; Gusnard, Akbudak,

Shulman, & Raichle, 2001). MPFC/BA 10 activates when participants think about their personality (Kelley et al., 2002), reflect on their emotions (Ochsner et al., 2004; Gusnard et al., 2001), and imagine themselves in the past or future (Spreng & Grady, 2010; Spreng, Mar, & Kim, 2009). MPFC/BA 10 is even sensitive to periods of increased self-consciousness across the life span (Somerville et al., 2013; Pfeifer et al., 2009; Sebastian, Burnett, & Blakemore, 2008). For example, one study induced children, adolescents, and adults to believe that their peers were monitoring their behavior during certain portions of a brain imaging experiment (Somerville et al., 2013). Adolescents (vs. children and adults) reported the greatest self-conscious emotions and showed the greatest MPFC/BA 10 activity during peer monitoring. Together, results from this literature converge to suggest that MPFC/BA 10 is critical to self-referential processing.

The second relevant observation is that MPFC/BA 10 is part of a brain system that generates disproportionate metabolic activity in the brain at rest. Neuroscientists have identified the “default network,” so named because these brain regions reliably engage by default, whenever our mind is free from external demands. For example, regions of the default network show correlated activity during extended periods of rest (Damoiseaux et al., 2006; Fox et al., 2005; Fransson, 2005; Greicius, Krasnow, Reiss, & Menon, 2003) and increased activation during momentary breaks from experimental tasks requiring attention to the external environment (Mazoyer et al., 2001; Raichle et al., 2001; Binder et al., 1999; Shulman et al., 1997). Several theoretical papers and meta-analyses have

¹Dartmouth College, ²University of California, Los Angeles

discussed the overlap in MPFC/BA 10 during rest and self-referential processing, suggesting the concordance reflects that people engage in self-referential processing when they are not attending to the outside world (Moran, Kelley, & Heatherton, 2013; Spreng et al., 2009; Buckner & Carroll, 2007). Although this work has been critical for hypothesis generation, whether MPFC/BA 10 activity during rest is performing a self-referential function remains empirically untested. Indeed, there is an additional implicit and untested assumption that MPFC/BA 10 engagement during rest is a consequence of self-referential processing. But, it is equally likely that the tendency for the brain to engage MPFC/BA 10 by default is actually the cause of self-referential thinking. Put another way, perhaps humans are biased toward thinking about themselves because MPFC/BA 10 engages by default and sets self-processing in motion.

This hypothesis—that MPFC/BA 10 activity during rest primes self-referential processing—builds off of earlier research, which finds that resting-state activity in other portions of the default network induces social cognitive processes. In a recent study, participants alternated between brief periods of rest and reasoning trials that either did or did not require reflecting on other people’s mental states (e.g., “why is he donating money?” vs. “how is he donating money?”; Spunt, Meyer, & Lieberman, 2015). Greater neural activity in dorsal MPFC (DMPFC/BA 9) during pretrial rest periods preferentially primed participants to answer mental state trials more efficiently, suggesting DMPFC/BA 9 activity during rest may bias people toward social cognitive processing. Importantly, DMPFC/BA 9 has been associated with social cognitive processes for both the self and others, whereas only MPFC/BA 10 preferentially supports self-reflection (Tamir & Mitchell, 2011; Spreng & Grady, 2010; van der Meer, Costafreda, Aleman, & David, 2010). Moreover, and relevant to the possibility that default MPFC/BA 10 activity may drive self-focus, graph theory-based research has demonstrated that MPFC/BA 10 is a functional anatomic hub of the default network (Andrews-Hanna, Reidler, Sepulcre, Poulin, & Buckner, 2010). In contrast, DMPFC/BA 9 is part of a subsystem that links to the MPFC/BA 10 hub (Andrews-Hanna et al., 2010), perhaps feeding social cognitive information to a core self-referential mechanism. Thus, although default activity in DMPFC/BA 9 may prime social thinking across self and nonself targets, the MPFC/BA 10 hub may specifically prime self-referential processing.

When testing the possibility that MPFC/BA 10 preferentially primes self-referential processing, it is important to rule out a viable alternative. Default network regions, particularly MPFC, have also been suggested to support generic forms of semantic processing during rest and task engagement (Seghier & Price, 2012; Binder, Desai, Graves, & Conant, 2009; McKiernan, D’Angelo, Kaufman, & Binder, 2006; McKiernan, Kaufman, Kucera-Thompson, & Binder, 2003; Binder et al., 1999; Mummery, Patterson, Hodges, & Price, 1998; Martin, Haxby, Lalonde, Wiggs, &

Ungerleider, 1995). An alternative possibility is that MPFC/BA 10 primes semantic thinking, with self-referential processing representing just one instance of a more general mechanism. This alternative possibility suggests a different pattern of predicted results. Namely, MPFC/BA 10 activity at rest would not only prime self-referential processing but also prime other forms of semantic processing. If this were the case, it would be difficult to argue that default MPFC/BA 10 engagement induces self-focus, as it should just as easily nudge people to access non-self-referential, semantic information.

In this study, we pit these possibilities against one another, testing for the first time whether MPFC/BA 10 activity during rest primes self-referential processing. During fMRI, participants shifted between (1) brief periods of rest, (2) judging their own traits (self-referential processing condition), (3) judging another well-known person’s traits (Barack Obama; social referential processing condition), and (4) judging a well-known location’s traits (the Grand Canyon; semantic processing condition that does not require self or social processing). Critically, we measured the speed with which participants made each trait judgment. We were therefore able to test whether pretrial MPFC/BA 10 activity during rest preferentially predicts how readily people engage self-referential processing.

METHODS

Participants

Nineteen participants (9 women; mean age = 23.88 years, $SD = 4.01$ years) were recruited from the University of California, Los Angeles (UCLA) community to participate in the study. This sample size was determined based on funding for the cost of fMRI data collection. All participants were right-handed, native English speakers, and not taking any psychiatric medications. Participants provided informed consent in accordance with the UCLA Institutional Review Board. One participant’s brain scan was discarded because of extreme artifacts in the data, leaving an fMRI sample size of $N = 18$.

Experimental Task

During fMRI, participants answered questions about three targets: themselves, Barack Obama (the current U.S. President at the time of participants’ scan session), and the Grand Canyon (Figure 1). Before each trait judgment, a cross-hair appeared on the screen for a variable duration (6–9 sec, mean = 7 sec). This range of rest duration was selected based on prior work examining default network priming (Spunt et al., 2015). Following the brief rest period, a task trial showed one of the three targets on the top of the screen (i.e., SELF; OBAMA; GRAND CANYON) and a corresponding descriptive trait (i.e., calm). Participants were instructed to determine, by

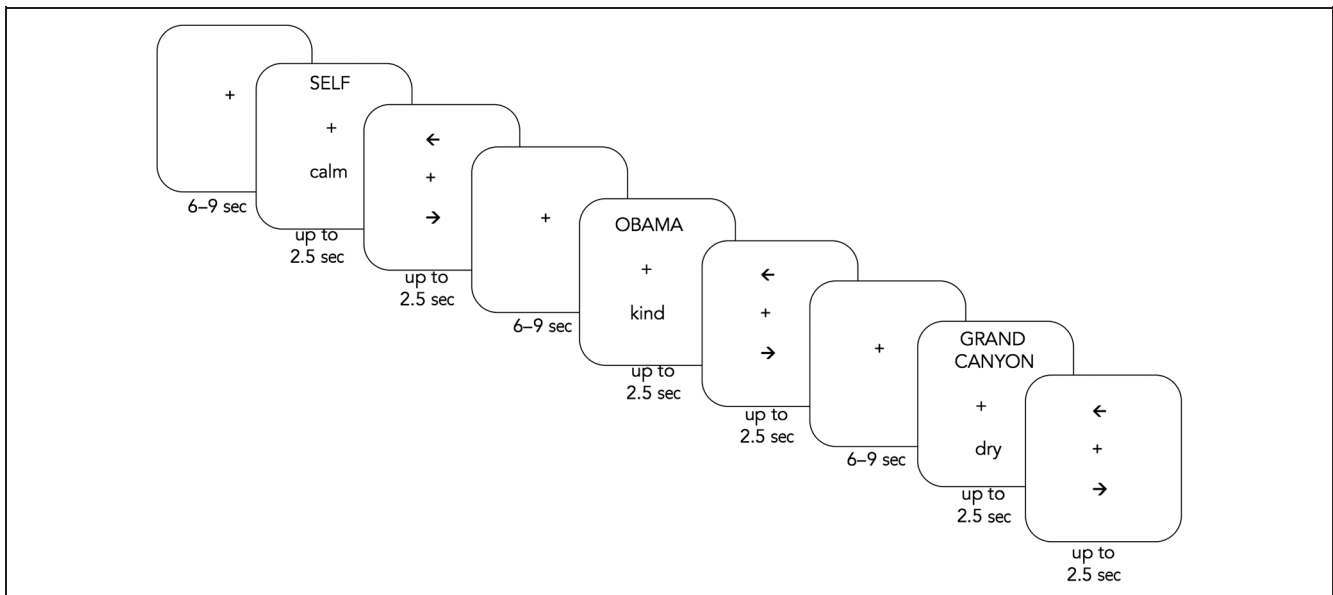

Figure 1. fMRI task schematic. While undergoing fMRI brain scanning, participants alternated between brief periods of rest, trait judgments, and attention-orienting trials.

pressing one of two buttons on a button box, whether or not the trait applies to the shown target. This paradigm is an adaptation of a previous paradigm developed by Kelley et al. (2002) to measure neural activity associated with self-referential processing. Past work with this paradigm similarly includes a condition for the self and other (e.g., Barack Obama; Jenkins & Mitchell, 2011; Zhu, Zhang, Fan, & Han, 2007; Kelley et al., 2002; Rogers, Kuiper, & Kirker, 1977). However, rather than the Grand Canyon trials used here as a control condition, nonsocial control condition trials in past work require participants to determine whether or not the text in a trial is shown in upper-case letters or lower-case letters. Although the case judgment control condition was useful for early work on self-referential processing, we employ a more tailored and stringent control condition to test our hypotheses. For the current study, we created the Grand Canyon condition, in which participants decide whether a descriptive trait (e.g., dry) applies to the Grand Canyon. Similar to the Self and Obama trials, Grand Canyon trials require semantic processing, without engaging self or nonself social cognitive processing.

Another adaptation added to the paradigm was the inclusion of an attention-orienting trial, which occurred directly after each trait judgment trial and immediately before the intertrial rest period. For these attention-orienting trials, participants decided whether the bottom arrow pointed in the same direction as the top arrow. The purpose of the attention-orienting trials was to create a neurocognitive “palate cleanse” between each trait judgment and subsequent rest period, facilitating the interpretation of any observed neural priming effects. Specifically, the attention-orienting trial served two related purposes. First, from the perspective of the participant, the attention-orienting trial should help rule out the possibility that

participants continued to think about the previous trait judgment trial during the subsequent rest period. Second, from the perspective of default network activity, attention-orienting trials should help protect against possible default network engagement during rest reflecting a carryover effect from the previous trait judgment trial, as the attention-orienting trials ought to diminish any lingering default network activity.

Participants were allotted up to 2.5 sec to make their trait judgment. Immediately after participants made their trait judgment, the screen advanced to the attention-orienting trial, for which participants also were allotted up to 2.5 sec to make their decision. After participants completed their attention-orienting trial, the screen advanced to the next cross-hair presented for a variable duration between 6 and 9 sec.

Participants completed 40 trials per condition. Following our previous work on default network priming (Spunt et al., 2015), trial order was randomized, with the constraint that no more than two trials from the same condition could be shown consecutively. Before completing their fMRI scan, participants completed computerized practice trials (unique from those employed in the fMRI task) to familiarize themselves with the task.

Brain Imaging Procedures

Brain imaging data were collected at the UCLA Ahmanson-Lovelace Brain Mapping Center with a 64-channel coil. Participants completed three runs of fMRI scanning (each ~9 min) during which time they performed the Self, Obama, and Grand Canyon task. These images were acquired with an anterior-to-posterior phase encoding using the following parameters: voxel size = $2 \times 2 \times 2$, repetition time = 72 msec, echo time = 37 msec, field

of view = 208 mm, slice thickness = 2 mm; multiband acceleration factor = 8. Each participant also underwent a high resolution T-1 weighted structural scan (magnetization-prepared rapid acquisition gradient-echo; voxel size = $1.1 \times 1.1 \times 1.2$ mm). Stimuli were projected to participants through LCD goggles, and their responses were recorded with a button box.

Brain Imaging Data Analysis

Brain imaging data were analyzed with Statistical Parametric Mapping (SPM12) software (Wellcome Department of Cognitive Neurology, London, England). Functional image volume preprocessing included realignment, normalization into Montreal Neurological Institute space, and spatial smoothing with a 6-mm FWHM Gaussian kernel. Next, following our past work (Spunt et al., 2015), we used a two-step approach to our subject-level statistical analyses. In the first step, a general linear model was created for each participant that included regressors for each trait judgment and attention-orienting trial, as well as six motion regressors derived from image realignment (high pass filter 128 sec). The group task activation analyses were performed on these subject-level models. The residual images from this subject-level model were saved (an option in SPM12's model estimation stage) and used for all subsequent priming analyses. Thus, because neural priming analyses were performed on these residual images, any observed neural priming effects should be independent of task-related activity.

In the second step, we performed parametric modulation analysis to test whether MPFC/BA 10 activity during rest preferentially primes self-referential or generic semantic processing. We created a first-level model (performed on participants' residual images) that comprised a regressor for the rest period before each trial in a condition, as well as a regressor that coded whether or not the current trait judgment trial was from the same condition as the previous trial, and finally, a regressor that included the RT for the trial that specifically followed the rest period. Each regressor was orthogonalized with respect to the previous regressor. Thus, parametric modulation analyses allowed us to explore how pretrial rest activity for each condition modulates the speed with which a participant answers the subsequent trial, independent of (1) the main effect of pretrial rest activity and (2) any priming effect that could be due to carryover effects from a previous trial in the same condition.

Because we had specific predictions regarding which regions should show neural priming effects and to limit the number of statistical tests performed on brain voxels, we performed group-level ROI analyses to test our hypotheses. To create accurate and independent ROIs associated with self, social, and semantic processing, we downloaded three reverse inference maps (one for each search term) generated by NeuroSynth (Yarkoni, Poldrack, Nichols, Van Essen, & Wager, 2011). The basic

reverse inference maps in NeuroSynth identify voxels that are preferentially associated with a psychological process. An MPFC voxel appearing in a reverse inference map for "self" indicates that studies in the NeuroSynth database tagged for "self" (i.e., where the word "self" appears at a high frequency in the text) were more likely to activate this voxel than studies in the NeuroSynth database not tagged for "self." It is important to note that the same voxel can show significant effects in reverse inference maps of multiple psychological terms. Thus, the maps for "self" and "semantic memory" show some overlap in MPFC.

Given that self-referential processing has been more associated with MPFC/BA 10 and generic social cognition has been more associated with DMPFC/BA 9 (Denny et al., 2012; Spreng & Grady, 2010), we constrained our ROIs accordingly (Figure 2A). Our "Self ROI" consists of voxels appearing in the NeuroSynth reverse inference map for "self" constrained to the medial aspect of BA 10 (voxels falling within the range of -12 to 22 in the z direction). The range of -12 to 22 in the z direction was used because these boundaries correspond with the Talairach Atlas's ventral and dorsal boundaries for BA 10 (Talairach, 1988). Our "Social ROI" consists of voxels appearing in the NeuroSynth reverse inference map for "social," constrained to medial BA 9 ($z \geq 22$). Because "semantic memory" yields a cluster in NeuroSynth that is entirely within medial BA 10, that cluster was included without further constraint for our "Semantic ROI" (Figure 2A). See Figure 2A for visualizations of the ROIs.

RT data and neural priming parameter estimates for each condition of interest were extracted for each participant, and hypotheses were tested with SPSS software (Version 23).

RESULTS

Behavioral Results

Our priming hypotheses are tested by examining whether pretrial neural activity during rest corresponds with people processing and therefore answering Self trials more rapidly. Before turning to the neural data, we therefore wanted to examine whether RT or the speed with which participants made a trait judgment varied by condition. A one-way repeated-measures ANOVA showed a significant main effect of Trial type, $F(1, 18) = 9.27, p = .001$ (Figure 2B; Self mean RT = 1.36, $SD = .21$; Obama mean RT = 1.39, $SD = .19$; Grand Canyon mean RT = 1.47, $SD = .20$; Canyon vs. Obama, $t(18) = 2.87, p = .005$; Obama vs. Self, $t(18) = 1.17, p = .131$; Self vs. Canyon, $t(18) = 4.17, p < .0001$). In later analyses, we examine whether these differences in processing speed reflect differences in MPFC/BA 10 priming for self, social, and nonsocial processing.

Neural Task Results

We created three ROIs for the analysis of the fMRI data. The Self ROI consisted of the voxels within the medial

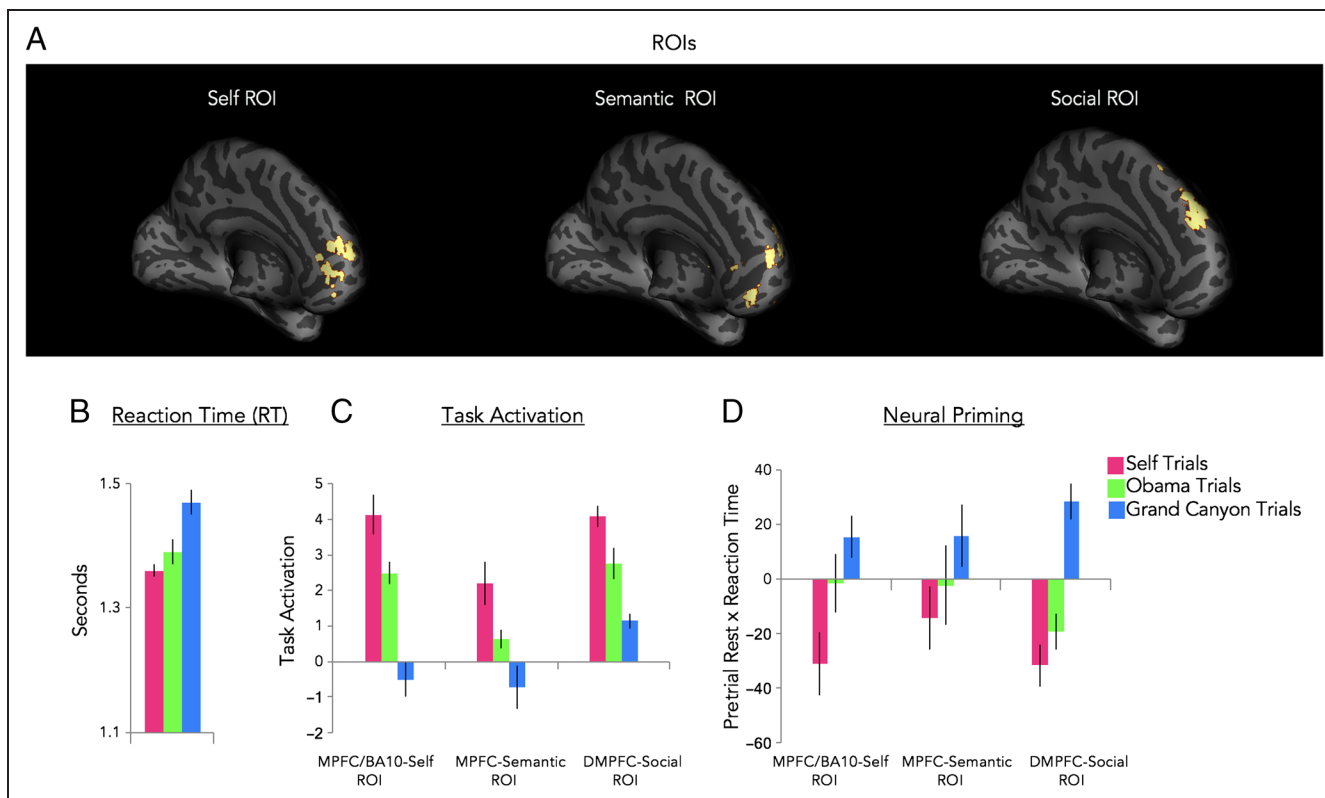

Figure 2. Results. (A) Reverse inference-based ROIs developed for the self, semantic, and social search terms. (B) Average RT for each trait judgment task. (C) Average neural activity for each trait judgment task, plotted separately for each ROI. (D) Neural priming effects for the trait judgment task, plotted separately for each ROI. For D, lower values indicate greater neural priming (i.e., greater activity during rest corresponds with faster [smaller] RT).

aspect of BA 10 that were also significant in a Neurosynth reverse inference analysis of the term “self.” The Social ROI consisted of the voxels within the medial aspect of BA 9 that were also significant in a Neurosynth reverse inference analysis of the term “social.” The Semantic ROI consisted of voxels within the medial aspect of BA 10 that were also significant in a Neurosynth reverse inference analysis of the term “semantic memory.” For more details, see the Methods section. All analyses were conducted on these three ROIs.

Before examining the rest periods for neural priming effects, we examined the task-specific patterns within the ROIs. As can be seen in Figure 2C, the same pattern was present in each ROI for the three trial types (Self > Obama > Grand Canyon). Within the Self ROI, effects significantly varied by task, $F(1, 17) = 15.70, p < .0001$, such that Self trials produced more activity than Obama trials, $t(17) = 2.44, p = .026$, and Obama trials produced more activity than Grand Canyon trials, $t(17) = 4.61, p < .0005$. Within the Social ROI, the same pattern was found with effects varying significantly by task, $F(1, 17) = 5.03, p = .012$, such that Self trials produced more activity than Obama trials, $t(17) = 2.16, p = .045$, and Obama trials produced more activity than Grand Canyon trials, $t(17) = 2.59, p = .019$. Within the Semantic ROI, we again observed effects varying by task, $F(1, 17) = 22.62, p < .0001$, such that Self trials produced more activity than Obama trials, $t(17) = 3.20, p = .0003$, and Obama trials produced more

activity than Grand Canyon trials, $t(17) = 3.87, p = .001$. Thus, even within the ROI identified as a reverse inference correlate of semantic processing, there is differential sensitivity to different kinds of semantic processes.

Neural Priming Results

We next explored the possibility that default activity in MPFC/BA 10 prompts people to think about themselves. Specifically, if default activity in MPFC/BA 10 preferentially primes self-referential processing, then we would expect the magnitude of activity in MPFC/BA 10 during rest periods to predict RTs on the next trial when the next trial involves self-processing, in comparison to social (i.e., Obama) and semantic (i.e., Grand Canyon) trials. In contrast, based on our prior work (Spunt et al., 2015), we would expect DMPFC/BA 9 to show priming-like benefits for Social trials relative to Grand Canyon trials and possibly also Self trials relative to Grand Canyon trials. Importantly, priming analyses were performed on participants’ residual images saved from their task activation general linear model (see Methods section). Thus, any observed priming effects are independent of task-related activity. We performed a 3 (ROI: Self ROI vs. Social ROI vs. Semantic ROI) \times 3 (Trial type: Self, Barack Obama, Grand Canyon) repeated-measures ANOVA, which was significant, $F(2, 34) = 2.90, p = .028$ (Figure 2D). Follow-up planned contrasts supported our predictions. Self ROI

pretrial rest showed greater priming for Self trials relative to Obama trials and Grand Canyon trials, $F(1, 34) = 5.16$, $p = .030$. Meanwhile, Social ROI pretrial rest showed greater priming for Obama and Self trials relative to Grand Canyon trials, $F(1, 34) = 7.37$, $p = .010$.

If MPFC/BA 10 engagement at rest primes general semantic processing, then the MPFC/BA 10 ROI associated with semantic processing should show similar benefits for all of our trial types, as each condition (Self, Obama, and Grand Canyon) requires semantic processing. In contrast to this possibility, however, the priming effect in the MPFC/BA 10–Semantic ROI was significantly stronger for the Self trials than the Grand Canyon trials, $t(17) = 2.31$, $p = .017$, and marginally stronger for the Obama trials than the Grand Canyon trials, $t(17) = 1.67$, $p = .057$. It should be noted that this Obama versus Grand Canyon effect is not due to significant priming for Obama trials, but rather significant interference for Grand Canyon trials. That is, for the Semantic ROI, mean parameter estimates for the Grand Canyon condition were significantly greater than baseline, $t(17) = 1.99$, $p = .031$, suggesting that MPFC/BA 10 activity at rest interferes with, rather than primes, nonsocial semantic processing.

DISCUSSION

Why do humans think about themselves so readily? This study suggests that default MPFC/BA 10 activity during rest may bias people toward self-referential processing. Specifically, the amount of MPFC/BA 10 activity during brief rest trials (6–9 sec) corresponded with faster RTs on subsequent self-referential trials, compared with non-self-referential trials. MPFC/BA 10 is a hub of the default network—consistently engaging whenever our minds are free from external demands to attention. This default tendency may nudge people toward self-focus and perhaps contribute to the host of egocentric biases that pepper everyday social life.

The results update our understanding of MPFC/BA 10 engagement during rest in two primary ways. First, the findings help rule out the possibility that MPFC/BA 10 activity during rest facilitates generic semantic processing, rather than self-referential processing per se. If MPFC/BA 10 activity at rest facilitates generic forms of semantic processing, then we would expect MPFC/BA 10 at rest to have also primed performance on the trials in which participants considered the Grand Canyon's traits, as these trial types also engage semantic processing. Contrary to this possibility, increased MPFC/BA 10 activity at rest corresponded with slower RTs on subsequent Grand Canyon trials. Thus, default activity in MPFC/BA 10 may actually interfere with, rather than facilitate, non-self-relevant semantic processing. Our results are consistent with recent findings that semantic representations are distributed throughout the brain and that the medial wall of the pFC preferentially responds to social

semantic categories (Huth, de Heer, Griffiths, Theunissen, & Gallant, 2016).

Second, to date, the suggestion that default MPFC/BA 10 activity at rest may underpin self-reflection has relied on reverse inference for support. Several meta-analyses and review papers have emphasized that the anatomical boundaries of brain activity look similar during rest and self-reflection, in turn suggesting that MPFC/BA 10 activity at rest may reflect spontaneous self-referential processing. Although this work has been critical for hypothesis generation, to our knowledge no work has directly tested the potential self-related functions performed during rest. Moreover, suggesting that MPFC/BA 10 engagement during rest simply reflects self-referential processing may overshadow self-processes that are unique to rest periods versus active self-reflection. Indeed, our data provide the first clue to this possibility, as greater MPFC/BA 10 activity at any given moment of rest preferentially primed future self-reflection.

MPFC/BA 10 has been associated with multiple aspects of self-reflection, including considering one's own traits (Kelley et al., 2002) and feelings (Ochsner et al., 2004), as well as imagining oneself in the past or future (Spreng & Grady, 2010). This region also engages when we consider other people who are highly self-relevant, such as individuals we are similar to (Mitchell, Macrae, & Banaji, 2006), close with (Krienen, Tu, & Buckner, 2010), and/or know a great deal about (Welborn & Lieberman, 2015). In fact, recent findings suggest MPFC/BA 10 may be a social information hub with organized, self-relevant person and trait knowledge (Heleven, Boukhlal, & Van Overwalle, 2017; Heleven & Van Overwalle, 2016; Ma et al., 2014) and thus MPFC/BA 10 at rest may facilitate ready access to such knowledge. Interestingly, other work has found that rest activation in other default network regions, specifically tempoparietal junction and temporal pole, helps people subsequently hear their own spoken name (Qin et al., 2016), suggesting aspects of self-reflection unrelated to conceptual self-knowledge may not be primed by MPFC/BA 10. Future studies that interweave rest periods with trials parameterized on self-relevance across domains (e.g., traits, mental states, prospection) may reveal the fine-grained self-processes primed by MPFC/BA 10 at rest. Such paradigms may also be leveraged to better understand how default network activity at rest relates to neural activation (in addition to behavioral performance) during self-referential processing.

Consistent with past work showing that DMPFC/BA 9 underpins social cognitive processes for both the self and others (Tamir & Mitchell, 2011; Spreng & Grady, 2010; van der Meer et al., 2010), DMPFC/BA 9 primed both self and nonself (Obama) social cognition. These findings also conceptually replicate and extend past work showing that DMPFC/BA 9 at rest corresponds with faster mental state processing. In a previous study, participants alternated between brief rest periods (6–9 sec) and randomly presented reasoning trials (Spunt et al., 2015) that either

did or did not require mental state reasoning. Greater DMPFC/BA 9 pretrial rest activity corresponded with preferentially faster RT on correctly answered mental state reasoning trials. Taken together, the present and previous results suggest that DMPFC/BA 9 activity at rest may prime multiple kinds of social reflection across targets from mental state reasoning to personality trait assessment.

Why would DMPFC/BA 9 prime multiple forms of social cognition while MPFC/BA 10 preferentially prime self-referential processing? On the one hand, some of the same mechanisms we use to understand others may be helpful for understanding ourselves, and thus, DMPFC/BA 9 may commonly support self and other processing. However, over the course of development, we also gain crystallized knowledge about our own identities and ways of experiencing the world (Pfeifer et al., 2009; Muller & Laird, 1971). Crystallized self-knowledge comes from a combination of social sources (e.g., “he thinks I am nervous”) and visceral sources (e.g., “I feel like I am nervous”). As a hub of the default network, MPFC/BA 10 has strong functional connections both to the DMPFC subsystem that supports generic social reflection (Andrews-Hanna et al., 2010) as well as sensory and limbic regions, which convey information about internal visceral states (Etkin, Egner, & Kalisch, 2011). Thus, through repeated coupling with other sources of information, self-reflection may become routinized in MPFC/BA 10 and function at rest to preferentially facilitate self-referential processing.

In conclusion, MPFC/BA 10 activity at rest primes self-referential processing. Success in a social world demands understanding who you are, how you fit within complex social networks, and being able to access this information on the fly. The tendency for MPFC/BA 10 to engage by default may help us readily think about ourselves in any given moment.

Reprint requests should be sent to Meghan L. Meyer, Department of Psychological and Brain Sciences, Dartmouth College, Hanover, NH, 03755, or via e-mail: meghan.l.meyer@dartmouth.edu or Matthew D. Lieberman, UCLA Psychology Department, 4611 Franz Hall, Los Angeles, CA 90095-1563, or via e-mail: lieber@ucla.edu.

REFERENCES

Andrews-Hanna, J. R., Reidler, J. S., Sepulcre, J., Poulin, R., & Buckner, R. L. (2010). Functional-anatomic fractionation of the brain's default network. *Neuron*, *65*, 550–562.

Binder, J. R., Desai, R. H., Graves, W. W., & Conant, L. L. (2009). Where is the semantic system? A critical review and meta-analysis of 120 functional neuroimaging studies. *Cerebral Cortex*, *19*, 2767–2796.

Binder, J. R., Frost, J. A., Hammeke, T. A., Bellgowan, P. S. F., Rao, S. M., & Cox, R. W. (1999). Conceptual processing during the conscious resting state: A functional MRI study. *Journal of Cognitive Neuroscience*, *11*, 80–93.

Bower, G. H., & Gilligan, S. G. (1979). Remembering information related to one's self. *Journal of Research in Personality*, *13*, 420–432.

Buckner, R. L., & Carroll, D. C. (2007). Self-projection and the brain. *Trends in Cognitive Sciences*, *11*, 49–57.

Crocker, J., & Knight, K. M. (2005). Contingencies of self-worth. *Current Directions in Psychological Science*, *14*, 200–203.

Damoiseaux, J. S., Rombouts, S. A. R. B., Barkhof, F., Scheltens, P., Stam, C. J., Smith, S. M., et al. (2006). Consistent resting-state networks across healthy subjects. *Proceedings of the National Academy of Sciences, U.S.A.*, *103*, 13848–13853.

Denny, B. T., Kober, H., Wager, T. D., & Ochsner, K. N. (2012). A meta-analysis of functional neuroimaging studies of self-and other judgments reveals a spatial gradient for mentalizing in medial prefrontal cortex. *Journal of Cognitive Neuroscience*, *24*, 1742–1752.

Dunbar, R. I., Marriott, A., & Duncan, N. D. (1997). Human conversational behavior. *Human Nature*, *8*, 231–246.

Epley, N., Keysar, B., Van Boven, L., & Gilovich, T. (2004). Perspective taking as egocentric anchoring and adjustment. *Journal of Personality and Social Psychology*, *87*, 327–339.

Etkin, A., Egner, T., & Kalisch, R. (2011). Emotional processing in anterior cingulate and medial prefrontal cortex. *Trends in Cognitive Sciences*, *15*, 85–93.

Fossati, P., Hevenor, S. J., Graham, S. J., Grady, C., Keightley, M. L., Craik, F., et al. (2003). In search of the emotional self: An fMRI study using positive and negative emotional words. *American Journal of Psychiatry*, *160*, 1938–1945.

Fox, M. D., Snyder, A. Z., Vincent, J. L., Corbetta, M., Van Essen, D. C., & Raichle, M. E. (2005). The human brain is intrinsically organized into dynamic, anticorrelated functional networks. *Proceedings of the National Academy of Sciences, U.S.A.*, *102*, 9673–9678.

Fransson, P. (2005). Spontaneous low-frequency BOLD signal fluctuations: An fMRI investigation of the resting-state default mode of brain function hypothesis. *Human Brain Mapping*, *26*, 15–29.

Greicius, M. D., Krasnow, B., Reiss, A. L., & Menon, V. (2003). Functional connectivity in the resting brain: A network analysis of the default mode hypothesis. *Proceedings of the National Academy of Sciences, U.S.A.*, *100*, 253–258.

Gusnard, D. A., Akbudak, E., Shulman, G. L., & Raichle, M. E. (2001). Medial prefrontal cortex and self-referential mental activity: Relation to a default mode of brain function. *Proceedings of the National Academy of Sciences, U.S.A.*, *98*, 4259–4264.

Heleven, E., Boukhil, S., & Van Overwalle, F. (2017). A stranger in my brain: Neural representation for unfamiliar persons using fMRI repetition suppression. *Social Neuroscience*. doi:10.1080/17470919.2017.1358663.

Heleven, E., & Van Overwalle, F. (2016). The person within: Memory codes for persons and traits using fMRI repetition suppression. *Social Cognitive and Affective Neuroscience*, *11*, 159–171.

Huth, A. G., de Heer, W. A., Griffiths, T. L., Theunissen, F. E., & Gallant, J. L. (2016). Natural speech reveals the semantic maps that tile human cerebral cortex. *Nature*, *532*, 453–458.

Jenkins, A. C., & Mitchell, J. P. (2011). Medial prefrontal cortex subserves diverse forms of self-reflection. *Social Neuroscience*, *6*, 211–218.

Johnson, S. C., Baxter, L. C., Wilder, L. S., Pipe, J. G., Heiserman, J. E., & Prigatano, G. P. (2002). Neural correlates of self-reflection. *Brain*, *125*, 1808–1814.

Kelley, W. M., Macrae, C. N., Wyland, C. L., Caglar, S., Inati, S., & Heatherton, T. F. (2002). Finding the self? An event-related fMRI study. *Journal of Cognitive Neuroscience*, *14*, 785–794.

Krienen, F. M., Tu, P.-C., & Buckner, R. L. (2010). Clan mentality: Evidence that the medial prefrontal cortex responds to close others. *Journal of Neuroscience*, *30*, 13906–13915.

Leary, M. R., & Baumeister, R. F. (2000). The nature and function of self-esteem: Sociometer theory. *Advances in Experimental Social Psychology*, *32*, 1–62.

- Linville, P. W. (1985). Self-complexity and affective extremity: Don't put all of your eggs in one cognitive basket. *Social Cognition*, 3, 94–120.
- Ma, N., Baetens, K., Vandekerckhove, M., Kestemont, J., Fias, W., & Van Overwalle, F. (2014). Traits are represented in the medial prefrontal cortex: An fMRI adaptation study. *Social Cognitive and Affective Neuroscience*, 9, 1185–1192.
- Markus, H. (1977). Self-schemata and processing information about the self. *Journal of Personality and Social Psychology*, 35, 63–78.
- Markus, H., & Kunda, Z. (1986). Stability and malleability of the self-concept. *Journal of Personality and Social Psychology*, 51, 858–866.
- Martin, A., Haxby, J. V., Lalonde, F. M., Wiggs, C. L., & Ungerleider, L. G. (1995). Discrete cortical regions associated with knowledge of color and knowledge of action. *Science*, 270, 102–105.
- Mazoyer, B., Zago, L., Mellet, E., Bricogne, S., Etard, O., Houdé, O., et al. (2001). Cortical networks for working memory and executive functions sustain the conscious resting state in man. *Brain Research Bulletin*, 54, 287–298.
- McConnell, A. R. (2011). The multiple self-aspects framework: Self-concept representation and its implications. *Personality and Social Psychology Review*, 15, 3–27.
- McKiernan, K. A., D'Angelo, B. R., Kaufman, J. N., & Binder, J. R. (2006). Interrupting the “stream of consciousness”: An fMRI investigation. *Neuroimage*, 29, 1185–1191.
- McKiernan, K. A., Kaufman, J. N., Kucera-Thompson, J., & Binder, J. R. (2003). A parametric manipulation of factors affecting task-induced deactivation in functional neuroimaging. *Journal of Cognitive Neuroscience*, 15, 394–408.
- Mitchell, J. P., Macrae, C. N., & Banaji, M. R. (2006). Dissociable medial prefrontal contributions to judgments of similar and dissimilar others. *Neuron*, 50, 655–663.
- Moran, J. M., Kelley, W. M., & Heatherton, T. F. (2013). What can the organization of the brain's default mode network tell us about self-knowledge? *Frontiers in Human Neuroscience*, 7, 391.
- Mullener, N., & Laird, J. D. (1971). Some developmental changes in the organization of self-evaluations. *Developmental Psychology*, 5, 233–236.
- Mummery, C. J., Patterson, K., Hodges, J. R., & Price, C. J. (1998). Functional neuroanatomy of the semantic system: Divisible by what? *Journal of Cognitive Neuroscience*, 10, 766–777.
- Naaman, M., Boase, J., & Lai, C. H. (2010). Is it really about me?: Message content in social awareness streams. In *Proceedings of the 2010 ACM Conference on Computer Supported Cooperative Work* (pp. 189–192). Savannah, GA: ACM.
- Ochsner, K. N., Knierim, K., Ludlow, D. H., Hanelin, J., Ramachandran, T., Glover, G., et al. (2004). Reflecting upon feelings: An fMRI study of neural systems supporting the attribution of emotion to self and other. *Journal of Cognitive Neuroscience*, 16, 1746–1772.
- Pfeifer, J. H., Masten, C. L., Borofsky, L. A., Dapretto, M., Fuligni, A. J., & Lieberman, M. D. (2009). Neural correlates of direct and reflected self-appraisals in adolescents and adults: When social perspective-taking informs self-perception. *Child Development*, 80, 1016–1038.
- Qin, P., Grimm, S., Duncan, N. W., Fan, Y., Huang, Z., Lane, T., et al. (2016). Spontaneous activity in default-mode network predicts ascription of self-relatedness to stimuli. *Social Cognitive and Affective Neuroscience*, 11, 693–702.
- Raichle, M. E., MacLeod, A. M., Snyder, A. Z., Powers, W. J., Gusnard, D. A., & Shulman, G. L. (2001). A default mode of brain function. *Proceedings of the National Academy of Sciences, U.S.A.*, 98, 676–682.
- Rogers, T. B., Kuiper, N. A., & Kirker, W. S. (1977). Self-reference and the encoding of personal information. *Journal of Personality and Social Psychology*, 35, 677–688.
- Sebastian, C., Burnett, S., & Blakemore, S. J. (2008). Development of the self-concept during adolescence. *Trends in Cognitive Sciences*, 12, 441–446.
- Seghier, M. L., & Price, C. J. (2012). Functional heterogeneity within the default network during semantic processing and speech production. *Frontiers in Psychology*, 3, 281.
- Shulman, G. L., Fiez, J. A., Corbetta, M., Buckner, R. L., Miezin, F. M., Raichle, M. E., et al. (1997). Common blood flow changes across visual tasks: II. Decreases in cerebral cortex. *Journal of Cognitive Neuroscience*, 9, 648–663.
- Somerville, L. H., Jones, R. M., Ruberry, E. J., Dyke, J. P., Glover, G., & Casey, B. J. (2013). The medial prefrontal cortex and the emergence of self-conscious emotion in adolescence. *Psychological Science*, 24, 1554–1562.
- Spreng, R. N., & Grady, C. L. (2010). Patterns of brain activity supporting autobiographical memory, prospection, and theory of mind, and their relationship to the default mode network. *Journal of Cognitive Neuroscience*, 22, 1112–1123.
- Spreng, R. N., Mar, R. A., & Kim, A. S. N. (2009). The common neural basis of autobiographical memory, prospection, navigation, theory of mind and the default mode: A quantitative meta-analysis. *Journal of Cognitive Neuroscience*, 21, 489–510.
- Spunt, R. P., Meyer, M. L., & Lieberman, M. D. (2015). The default mode of human brain function primes the intentional stance. *Journal of Cognitive Neuroscience*, 27, 1116–1124.
- Symons, C. S., & Johnson, B. T. (1997). The self-reference effect in memory: A meta-analysis. *Psychological Bulletin*, 121, 371–394.
- Talairach, J. (1988). *Co-planar stereotaxic atlas of the human brain: 3-D proportional system: An approach to cerebral imaging*. New York: Thieme.
- Tamir, D. I., & Mitchell, J. P. (2011). The default network distinguishes construals of proximal versus distal events. *Journal of Cognitive Neuroscience*, 23, 2945–2955.
- Tamir, D. I., & Mitchell, J. P. (2013). Anchoring and adjustment during social inferences. *Journal of Experimental Psychology: General*, 142, 151–162.
- van der Meer, L., Costafreda, S., Aleman, A., & David, A. S. (2010). Self-reflection and the brain: A theoretical review and meta-analysis of neuroimaging studies with implications for schizophrenia. *Neuroscience and Biobehavioral Reviews*, 34, 935–946.
- Welborn, B. L., & Lieberman, M. D. (2015). Person-specific theory of mind in medial pFC. *Journal of Cognitive Neuroscience*, 27, 1–12.
- Yarkoni, T., Poldrack, R. A., Nichols, T. E., Van Essen, D. C., & Wager, T. D. (2011). Large-scale automated synthesis of human functional neuroimaging data. *Nature Methods*, 8, 665–670.
- Zhu, Y., Zhang, L., Fan, J., & Han, S. (2007). Neural basis of cultural influence on self-representation. *Neuroimage*, 34, 1310–1316.