



The Society shall not be responsible for statements or opinions advanced in papers or discussion at meetings of the Society or of its Divisions or Sections, or printed in its publications. Discussion is printed only if the paper is published in an ASME Journal. Authorization to photocopy for internal or personal use is granted to libraries and other users registered with the Copyright Clearance Center (CCC) provided \$3/article is paid to CCC, 222 Rosewood Dr., Danvers, MA 01923. Requests for special permission or bulk reproduction should be addressed to the ASME Technical Publishing Department.

Copyright © 1999 by ASME

All Rights Reserved

Printed in U.S.A.

## PIONEERING TURBOJET DEVELOPMENTS OF DR. HANS VON OHAIN— FROM THE HeS 1 TO THE HeS 011



Cyrus B. Meher-Homji  
Bechtel Corporation  
Houston, Texas, USA.

Erik Prisell  
Defence Materiel Administration (FMV)  
Stockholm, Sweden

### ABSTRACT

On March 13th, 1998, Dr. Hans Joachim Pabst von Ohain co-inventor of the turbojet passed away at the age of 86. As a young doctoral student, von Ohain conceived of and built a demonstrator turbojet engine. He was hired by the Heinkel Aircraft Company in 1936 and under intense time pressure imposed by Ernst Heinkel, designed the world's first flight turbojet engine. This paper traces the technical antecedents leading to historic jet-powered flight made on August 27, 1939 by a Heinkel He 178 aircraft powered by von Ohain's HeS 3B turbojet. During his tenure at Heinkel and thereafter at the Heinkel-Hirth Company, he was responsible for a series of turbojet engines culminating in the advanced second generation HeS 011 with a thrust of 2,860 lbs. This paper is a tribute to an outstanding scientist who made possible the turbojet revolution and who will forever be remembered as the inventor of the world's first flight turbojet.

### 1. INTRODUCTION

Early morning on the 27<sup>th</sup> of August 1939, five days before the outbreak of the Second World War, a small group of people assembled at the Heinkel airfield at Marienehe close to Rostock to witness the first flight of a He 178 turbojet powered aircraft flown by test pilot Erich Warsitz. Among those present were Ernst Heinkel, von Ohain the young and brilliant designer of the turbojet, Max Hahn and Wilhelm Gundermann who worked on the small team that developed the world's first flight engine, the HeS 3B. The flight, which lasted approximately 6 minutes, changed the course of aircraft and propulsion history. An account of Dr. von Ohain's work is presented with technical details of his turbojet designs culminating in the HeS 011 which was considered the most advanced jet engine design at the end of the Second World War.

#### 1.1 Antecedents.

Dr. Hans von Ohain in Germany and Sir Frank Whittle in England, both of whom are considered co-inventors of the turbojet engine, pioneered the turbojet revolution. Constant (1980), Schlaifer (1950), Von Ohain (1979), Scott (1995), and Jones (1989) have documented their work. Both Whittle and von Ohain independently envisioned flight speeds in excess of 500 mph at altitudes of 30,000 feet, had revolutionary ideas as students, and developed their engines without the help of the traditional aeroengine companies. In order to put the

development of Ohain's jet engines built prior to and during the Second World War into a historical perspective, it is necessary to trace the course of Ohain's thinking and the theoretical and practical developments relating to gas turbines before the Second World War and examine the factors that led Heinkel into taking on the risk of turbojet development.

#### 1.2 Overview of Turbojet Development in Germany.

Turbojet development in Germany initially included two independent programs that were not, at least initially, under the auspices of the German Air Ministry (RLM<sup>1</sup>). As is typical of revolutionary technological changes, these two programs did not initiate at the traditional aeroengine companies but started at Heinkel Airframe and at Junkers Airframe Company. Ultimately, both these developments ended up under Heinkel, but as we will see later, despite a pre-eminent position in the area of turbojet engine and jet aircraft development, Heinkel could not capitalize on his position as a jet age pioneer.

#### 1.2.1 Engine Development Sponsored By Ernst Heinkel.

Von Ohain developed the idea of his jet engine while he was a doctoral student at the University of Göttingen. By 1934, he had completed rudimentary design calculations that indicated speeds of 500 mph were possible. He initiated patent procedures and decided to build a working model of the engine. Working with Max Hahn, an expert mechanic and machinist and a natural engineer, he built his first model engine which was plagued by combustion problems. Von Ohain's Professor R.W. Pohl, introduced von Ohain to Ernst Heinkel, the legendary aircraft manufacturer whom Pohl knew, was obsessed with high-speed flight. As a result, the 25 year old Ohain was interviewed by Heinkel and his leading engineers, and was hired by Heinkel.

Ernst Heinkel had come into prominence during the First World War when he was the chief designer of the Hansa-Brandenburgischen Flugzeugwerke and he was noted as a designer of a wide variety of marine aircraft. Heinkel formed his own company in 1922 and produced several well-known aircraft. His obsession with speed was triggered in September 1927 when he visited Venice to see the famous Schneider Cup race. When viewing the fast aircraft on display, Heinkel was seized with an intense desire to build fast aircraft. (Heinkel, 1956). It was at this event that Claudius Dornier, while standing with him viewing a high performance Fiat engine, uttered the following prophetic words to Heinkel "If only we had a single engine like that, we

<sup>1</sup> The German National Ministry of Aviation was known as the Reichsluftfahrtministerium or RLM for short.

could be in this race, but the way our aviation industry is going, we shall never get a decent one." Heinkel stated in his memoirs that this was indeed a true statement and that German engines, as the result of the setbacks suffered between 1918 and 1933, never caught up with the rest of the world nullifying the advantages achieved in the field of airframe aerodynamics. This disillusionment with the German aircraft engine industry persisted with Heinkel and was *certainly a factor in his plunging forth with the bold new concept proposed by the young von Ohain nine years later.*

After getting intoxicated by speed, Heinkel hired Siegfried and Walter Guenther who were identical twins. The Guenther brothers were brilliant and gifted designers responsible for several of Heinkel's competition winning designs and also for the graceful jet aircraft designs developed by Heinkel. They were responsible for the famous He 70 (the Heinkel Blitz) which won eight international speed records in 1933. This aircraft was fitted with a 600 HP BMW engine, which represented a technology lag from the US, English, and French engines at that time. The He 70 had such good aerodynamics that one was actually purchased by Rolls Royce to test and demonstrate their 810 HP Kestrel V engine<sup>2</sup>. The Gunther brothers were present at von Ohain's initial interview with Heinkel and recognizing the limitations of propellers for high-speed flight, were enthused by his jet concept.

As described in detail below, Heinkel hired von Ohain in 1936 and this brilliant young physicist put him in the position to fly the world's first turbojet powered aircraft in August 1939. Von Ohain and Max Hahn started work at Heinkel Marienehe Works under a shroud of secrecy and were given instructions to develop a jet engine as rapidly as possible with the stipulation that ground tests were to begin within a year. The first engine designated as the He S1, was a demonstrator engine that operated on hydrogen fuel and was successfully test run in March 1937. Continuing development, von Ohain's team had the HeS 3B engine operational and the historic first pure jet-powered flight of the He 178 powered by a HeS 3B turbojet occurred on August 27th, 1939, a few days before the start of the Second World War. Heinkel immediately informed high air ministry officials of this momentous event, but was met with indifference. The German Air Ministry ordered Heinkel to cease all research on jet engines but Heinkel, convinced that his political connections would ultimately result in a profitable contract, kept von Ohain's team working on turbojets. A few months later, Heinkel's proposal for a jet fighter (the He 280) was accepted by the RLM. This aircraft was to be powered by two HeS 8A engines designed by von Ohain<sup>3</sup>. After the first flight of the He 280, the RLM allowed Heinkel to purchase the Hirth Motoren and in doing so Heinkel had full-fledged engine manufacturing capability. Von Ohain moved to the Heinkel-Hirth Company and continued engine development work there. The RLM cancelled the He 280 on March 27, 1943 and development of the HeS8A was curtailed by the RLM in mid 1942 in favor of the Jumo 004 and BMW 003 engines.

**1.2.2 Turbojet Engine Development Initiated At Junkers Aeroplane Company.** During 1936 and 1939, engineers at another aircraft manufacturer, Junkers Aeroplane Company, were working on jet engines under the guidance of Prof. Herbert Wagner. Wagner, a brilliant airframe designer was well-versed in steam turbine design and wanted to develop jet engines which, he felt, would make Junkers a pre-eminent aircraft company. By 1938, Junkers had 30 designers and draftsmen working on the project at their Magdeburg plant and were in the process of

developing a demonstrator, that had a 12 stage axial compressor, single combustor and a two-stage turbine. This team included Max Adolf Mueller who was at one time an assistant to Prof. Wagner at the Technical University in Berlin and was now project manager for the Wagner jet engine studies. Later, the RLM insisted that engine development work be taken over by Junkers engine company (Junkers Motoren at Dessau). Mueller, who objected to the organizational changes, and 12 members of his team, left Junkers and were hired by Heinkel in the summer of 1939, thus bringing the Wagner engine program to Heinkel. Included in this team was Dr. R. Friedrich, an outstanding compressor aerodynamicist.

**1.2.3 Official Turbojet Programs of the RLM (German Air Ministry).** A pictorial overview of the course and chronology of German turbojet development is shown in Figure 1 including the key aircraft developed. Also shown are aircraft that were planned for deployment using the second generation HeS 011 engine.

In 1938, Helmut Schelp and his senior, Hans Mauch in the German Air Ministry (RLM) had ambitious jet engine development programs in mind and were trying to work with the aeroengine manufacturers to interest them in jet engine development. Schelp was aware of the limitations of piston engines for higher speeds and had concluded that jet propulsion was the solution<sup>4</sup>. Schelp was unaware of the ongoing research at Heinkel Airframe or Junkers Airframe Company. The prevailing feeling at that time was that compressor and combustor efficiencies were too low to permit a practical jet engine. Schelp, however, knew of three leading compressor engineers; Professors Prandtl, Betz and Encke who worked at the Aerodynamic Research Establishment (AVA) at Gottingen and had been successful in designing compressors based on aerodynamic airfoil theory. Schelp recognized that their work could provide the impetus required in developing a practical engine.

In 1938, Schelp and Mauch visited four dominant aeroengine manufacturers- BMW, Junkers Aeroengine Company, Daimler Benz and Bramo. The head of Junkers Aeroengine, Otto Mader, reluctantly accepted a small development engineering contract. He was not aware of Wagner's ongoing program at Junkers Airframe Company mentioned above. Daimler Benz refused Schelp's offer for funding. Bramo, fearful that they would soon face severe competition in piston engine orders to their rivals BMW, agreed to perform a study. BMW took on a study contract. Later during the war, the BMW company developed the 003 engine under the leadership of Dr. Herman Oestrich.

Ultimately, all German turbojet development work came under RLM control. The RLM insisted that all engine development be done at engine companies<sup>5</sup>. At the Junkers Aeroengine Company (Junkers Motoren or Jumo for short), work proceeded on the deliberately conservative Junkers Jumo 004 engine under the leadership of Anselm Franz. This engine, which powered the Me 262, was the world's first high volume production turbojet (Meher-Homji, 1997). As mentioned above, Heinkel was permitted to purchase the Hirth Corporation, which gave him access to engine manufacturing technology. Both the von Ohain and Mueller engine programs were moved to the Heinkel-Hirth Corporation essentially under RLM control.

<sup>2</sup> Heinkel actually tried to negotiate a deal with the British Air ministry to trade license of the He 70 manufacture for the license to build and develop Rolls Royce Engines in Germany. This deal was not permitted by the German Air Ministry who assured Heinkel that German aeroengine development was soon to "surpass the achievements of the foreign aircraft engine builders."

<sup>3</sup> Nine prototypes of the He-280 were built and in the spring of 1942 the prospects for this aircraft were favorable as the Jumo 004 was, at that time, plagued by problems. Once these problems were resolved by Franz and Bentele, the Me 262 proved to be superior to the He-280 and was thus chosen for production.

<sup>4</sup> Schelp was aware of the work of Armengaud and Lemale published before 1910 in which jet propulsion was put forward.

<sup>5</sup> Mauch had actually suggested that Heinkel's jet engine team be the nucleus of a jet development effort to be established at Daimler-Benz, an offer which Heinkel refused.

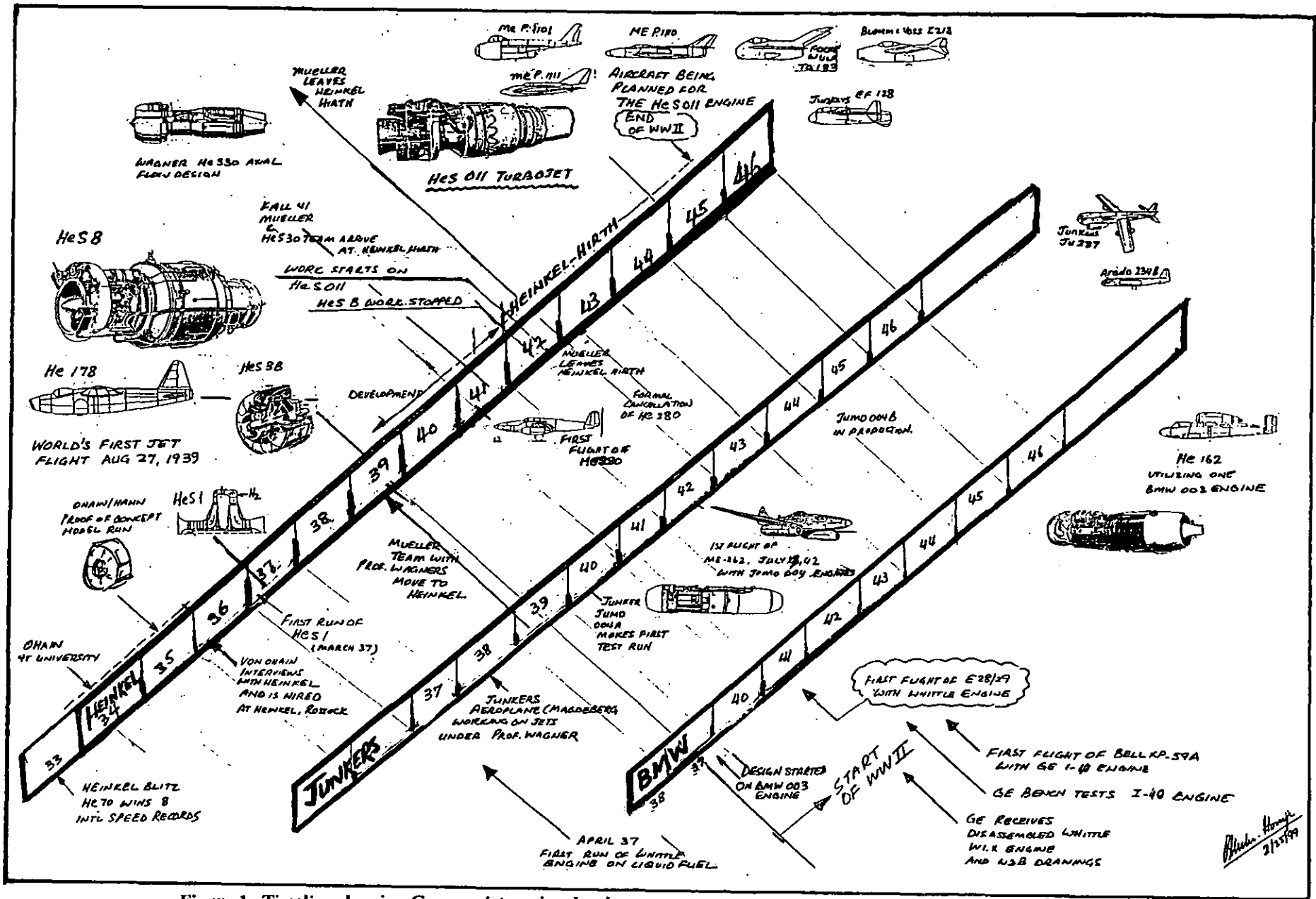

Figure 1. Timeline showing German jet engine development program and operational and planned turbojet aircraft.

## 2. VON OHAIN'S EARLY WORK

Von Ohain developed the idea of his jet engine while he was a doctoral student at the University of Göttingen when he was working towards his Ph.D. under the renowned Professor Pohl. During a flight on a Junkers Trimotor aircraft, von Ohain was appalled by the high noise and vibration caused by the reciprocating engines and instinctively felt that the combination of aerodynamic aircraft would be more matched, in an aesthetic sense, with a continuous flow aerothermodynamic engine. Spurred on by this initial feeling, von Ohain, in the Fall of 1933, started thinking about a steady aerodynamic flow process involving a project based on a modified "Nernst" turbine<sup>6</sup> and his preliminary calculations indicated that such a system would have great advantages in terms of power to weight ratio. With his design goal of simplicity for a working model, he chose a centrifugal compressor and radial inflow turbine layout to minimize matching problems. Even at this early date, von Ohain recognized that importance of minimizing frontal area by the use of axial flow compressors but opted for the simpler radial design for the initial models.

By 1934, he had completed rudimentary design calculations that indicated speeds of 500 mph were possible based on a pressure ratio of 3:1 and a turbine inlet temperature of 1200 to 1400 F. Although the fuel consumption was high, von Ohain calculated that the turbojet's weight would be about a fourth that of a reciprocating engine. He initiated patent procedures and decided to build a working model of the engine at his own expense. Von Ohain developed a friendship with Max Hahn an expert mechanic, machinist and a natural engineer<sup>7</sup>, who was the chief mechanic at the Bartells and Becker car repair shop in Göttingen where he used to have his car repaired. Von Ohain showed Hahn his initial sketches and Hahn made suggestions for simplification to enable manufacture. The prototype model was built by Hahn and funded by von Ohain with the initial estimate being 1000 marks. The engine is shown in Figure 2. This engine did not self sustain due to combustion problems but did result in unloading of the starter. Ohain made temperature and pressure distribution measurements and recounted that Hahn, who was normally most stern and skeptical, was in this instance most optimistic because of the unloading of the starter and the high velocity flame emanating from the jet pipe!<sup>8</sup> Ohain realized right away that liquid fuel combustion would be a formidable challenge that would take considerable financial and technical resources to overcome.

Professor R.W.Pohl<sup>9</sup> at Göttingen University was very supportive of this extracurricular work and permitted experiments to be conducted in the backyard of his institute, supplying von Ohain with instrumentation and a starter motor. Convinced that von Ohain's theory was right and that this concept had a future, he recommended to von Ohain that industrial sponsorship would be needed for further development and indicated his willingness to write a letter of recommendation to an aeroengine company of von Ohain's choice. Von Ohain wisely chose the aircraft manufacturer Ernst Heinkel as he was aware of Heinkel's obsession for high-speed aircraft and that his reputation as a risk taker.<sup>10</sup> Another factor in this choice was the fact that von Ohain loved the Baltic Sea and sailing and the Heinkel works at

<sup>6</sup> Von Ohain initially investigated concepts not involving moving machinery by bringing incoming ram air in contact with the expanding gas but the problems with heat transfer and losses caused these ideas to be replaced by a compressor—turbine concept.

<sup>7</sup> Von Ohain always had the greatest respect for Max Hahn's natural engineering and practical skills and being a man of great humility, always mentioned Hahn's contribution in both his talks and subsequent papers. Max Hahn followed Ohain to Heinkel and worked closely on the development of the early engines till the end of the war.

<sup>8</sup> As described by Ohain- this was like a flame thrower!

<sup>9</sup> Prof. R.W.Pohl was von Ohain's Professor for his doctorate which was in physics. Von Ohain had minored under Prof. L. Prandtl in the area of applied mechanics.

<sup>10</sup> This choice was very correct as the traditional aircraft engine companies were reluctant to study jet propulsion as Schelp would find out at a later date. All the initial jet development work in Germany was done by aircraft companies and not aeroengine companies.

Rostock was perfect for this. Von Ohain intuitively recognized that the traditional aeroengine companies would resist the revolutionary design that he was proposing.

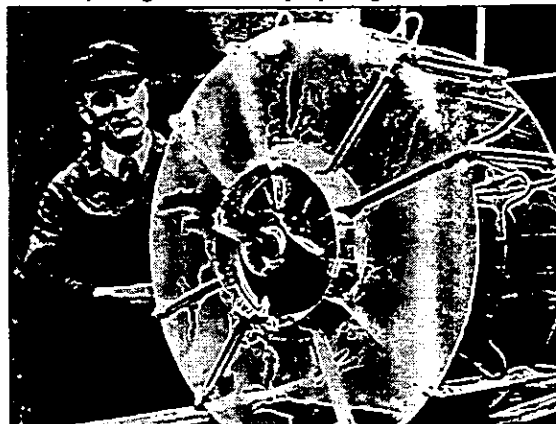

Figure 2. Prototype model (1934) which did not self sustain.

## 3. TURBOJET ENGINE DEVELOPMENT WORK AT HEINKEL

In February 1936 Pohl wrote to Heinkel and as a result, the 25 year old von Ohain was summoned to Heinkel's house on the Baltic Coast. According to Ohain (1989) during his discussion with Heinkel on the evening prior to the day long interview, Heinkel listened to his proposal and asked him point blank as to what the problem areas were with his proposed engine as he wanted to know if this young Ph.D. had a sense of reality. Von Ohain indicated to him that the problem was the high fuel consumption but that this could be improved as development efforts proceeded.

The next day, Ohain met with the leading engineers at Heinkel and after a grueling one-day interview, in which he skillfully addressed all questions, he succeeded in convincing Heinkel to hire him!<sup>11</sup> Included in this group were Walter and Siegfried Guenther, Heinkel's leading aerodynamicists, who instantly recognized the importance of jet propulsion for high-speed flight. An employment contract was issued to von Ohain on April 15, 1936.

### 3.1 The HeS 1 Demonstrator Engine.

Von Ohain and Max Hahn (whom von Ohain insisted be hired) started work under a shroud of secrecy in a special building in Marienehe and were given instructions to develop a jet engine as rapidly as possible with the stipulation from Heinkel that bench tests were to begin within a year. The project was deliberately given a vague name of "Sonder-Entwicklung (Special Development) and the work started with a team including Max Hahn and Wilhelm Gundermann, a gifted Heinkel designer, and two draftsmen. Heinkel kept this work secret from the German Air Ministry (RLM), the Luftwaffe, and engine manufacturers.<sup>12</sup>

The rather over-ambitious schedule stipulated by Heinkel forced von Ohain to deviate from his original plan which was to systematically conduct studies and tests and solve the combustion problems. Recognizing the politics of the situation, von Ohain made the conscious decision that a simple engine run on hydrogen fuel would provide the impetus needed for such a

<sup>11</sup> Part of the reason for Heinkel hiring von Ohain was to prevent him from going to his archrival, Messerschmitt. This rivalry continued throughout the war in the race to produce the first jet fighter. For example, in 1940/41, Messerschmitt delayed for months, by political means, Heinkel's acquisition of Hirth Motoren GmbH (Schlaifer, 1950).

<sup>12</sup> Hans Mauch of the RLM actually visited Heinkel in the summer of 1938 about one year prior to the first jet powered flight. He witnessed the operation of the hydrogen fueled demonstrator engine, and this helped convince him of the need for turbojets for high speed flight.

project, quickly demonstrate a tangible running engine to Heinkel<sup>13</sup> and buy him some time for systematic combustion investigations. After this decision was made, he started parallel investigations into the use of liquid fuels and even visited industrial fairs in Leipzig in order to elicit support from burner manufacturers for the design of a high intensity combustor. Not finding any support, he realized that this formidable problem would have to be solved by his own team. Work proceeded, with von Ohain providing the overall technical direction, laying out the engine and conducting thermodynamic studies, Gundermann working on the mechanical design and stress analysis and Hahn working on manufacturing techniques and combustion.

The HeS 1<sup>14</sup> layout is shown in Figure 3. It consisted of a back-to-back radial compressor and a radial inflow turbine. The rotor diameter was 12". The centrifugal compressor was preceded by an axial entry stage. The hydrogen combustor consisted of a large number of hollow vanes with blunt trailing edges placed within the air duct between the compressor and the radial inflow turbine. The engine was made essentially of sheet steel fabricated at the Martenehe works and disks fabricated at a nearby shipyard. The engine operated at a speed of 10,000 rpm and produced a thrust of 250 Lbs (1.1kN). Von Ohain's choice of hydrogen as a fuel was wise, as the demonstrator combustor did not present any significant problems because of the high flame velocity and the wide combustion range of hydrogen. It also performed flawlessly under off design conditions and during transient acceleration and deceleration.

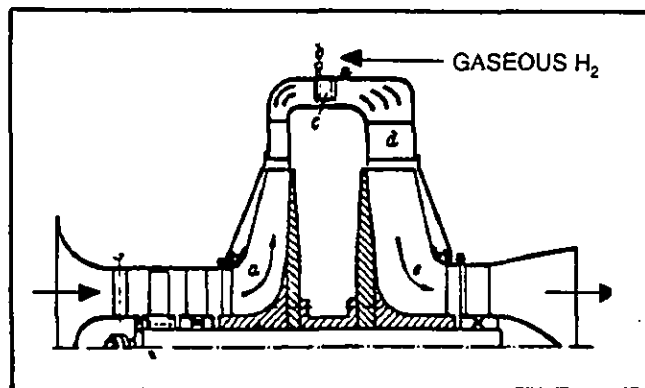

Figure 3. HeS 1 Demonstrator run on hydrogen fuel

In the Spring of 1937 the engine was demonstrated early one morning in front of Ernst Heinkel, which had a major impact on von Ohain's position at Heinkel. The young von Ohain was now established as a brilliant engineer and received a letter of recommendation and a pay increase from Heinkel. Dr. von Ohain received a permanent contract and was named head of the Heinkel jet propulsion development. After this successful engine run, Heinkel pushed hard for a flight engine operating on liquid fuel. This led to the design and development of the HeS.2<sup>15</sup> engine and finally the HeS 3 engine.

### 3.2 Design and Development of the HeS 3A and HeS 3B Engine.

Starting in May 1937, after the running of the HeS.1 engine, work was intensified on the combustor development. The

<sup>13</sup> An important attribute of an innovator is the recognition that design compromises are often required for success and that often a technically elegant design may not lead to long term success. Both Dr. von Ohain and Sir Frank Whittle had this insight.

<sup>14</sup> The designation stands for He = Heinkel, S = Strahltriebwerk = Jet engine. This same designation was continued when Heinkel purchased Hirth.

<sup>15</sup> The HeS 2 had the same turbomachinery components as did the HeS 3 but utilized hydrogen in its combustor.

combustor investigation program included the following elements (Ohain, 1979)

- Installation of a 2 HP blower with controllable bypass to allow testing.
- Investigations on segments of annular combustors to evaluate influence of combustor shape, flame holding mechanisms and optimization for minimizing pressure drop<sup>16</sup>
- Fuel vapor generation and injection into the combustor by electrical heating
- Atomization studies.

By 1938 a combustor with excellent operational characteristics was developed. This combustor used vaporized fuel, but there were still difficulties with atomizing that had to be overcome.

Design work had begun on the flight engine (designated as the HeS 3) and in May 1937, and in September 1937, Max Hahn suggested the idea of arranging the combustor in the large unused space in front of the centrifugal compressor a concept that would reduce shaft size and engine weight. Dr. von Ohain was very impressed by Hahn's idea and encouraged him to apply for a patent and the idea was incorporated in the engine layout by von Ohain. The patent drawing is shown in Figure 4 (Bamford and Robinson, 1945)

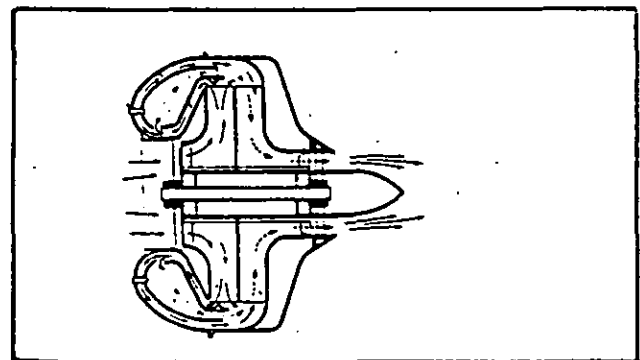

Figure 4. Patent drawing of Hahn showing combustor located in front of centrifugal compressor.

The first HeS 3A was tested in 1938, but did not produce the design thrust required because a small compressor and combustor had been used to reduce the frontal area. The engine was, therefore, completely redesigned and resulted in the HeS 3B. This engine attempted to increase the mass flow by having a high hub /tip ratio and von Ohain minimized the inlet losses by using an axial inducer stage which, in addition to contributing to an increased pressure ratio, also provided a counter swirl thus decreasing the inlet relative Mach number and curvature of the inlet blade. The layout of the flight engine is shown in Figure 5. The inlet section of the HeS 3 is shown in Figure 6. The wraparound combustor is shown in Figure 7 and the radial inflow turbine is shown in Figure 8.

The engine had a speed of 13,000 rpm, a weight of 793 lbs (360 kg), and frontal area of 7.31 sq. ft. (0.68 m<sup>2</sup>). Figure 9 shows the performance characteristics of this engine (AEL Report, June 1945).

## 4. THE He 178 THE WORLD'S FIRST JET AIRCRAFT.

Design on the He 178 was led by Dr. Heinrich Hertel and worked on by the Guenther twins. The basic design was laid out by Walter Guenther but after his tragic death in a car accident in September 1939, the work was carried out by Heinrich Helmbold and Siegfried Guenther who kept Walter Guenther's design

<sup>16</sup> Since the segments were circumferentially small, the sidewall effects reduced the usefulness of the tests.

concept unchanged. The aircraft was to use the HeS 3 engine. The He 178 (Figure 10) was a small shoulder winged airplane

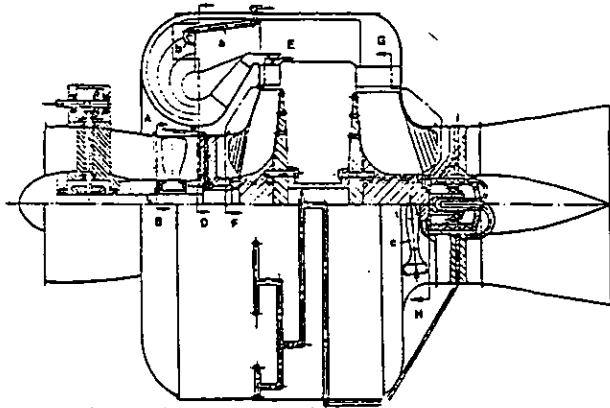

Figure 5. Layout of the HeS 3B flight engine (Gunston 1995).

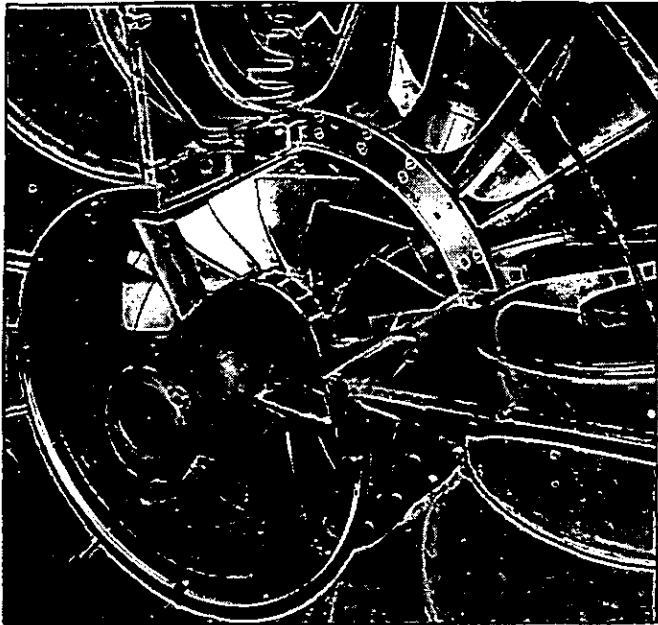

Figure 6. Inlet section of the HeS 3B showing inducer and centrifugal compressor

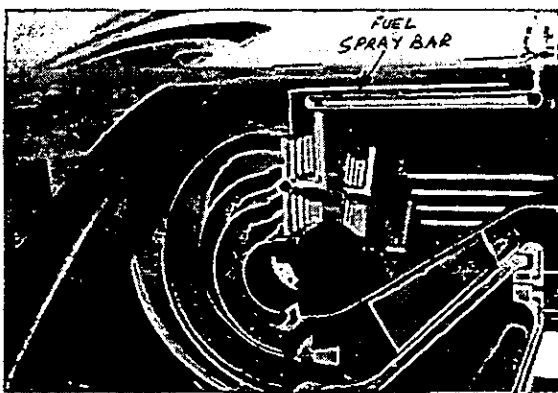

Figure 7. Combustor section of the HeS 3B.



Figure 8. Radial inflow turbine of the HeS 3B.

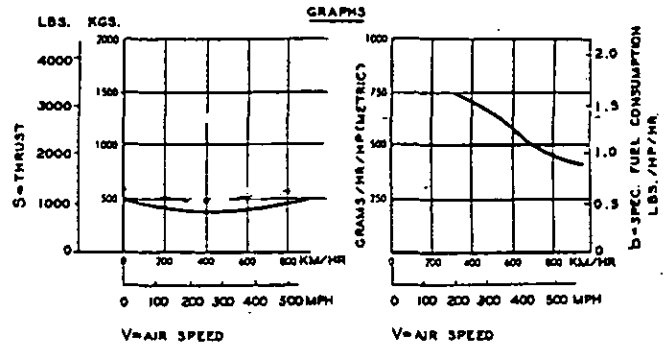

Figure 9. Performance characteristics of the He S3B.

having a wing span of 23' 7" (7.2 m) and a length of 24' 6" (7.48m). The wings were mostly of wooden construction with a small dihedral angle. Air for the single HeS 3B engine was drawn in from a nose intake and routed to the engine via a duct that went below the pilot's seat. The fuel tank was located behind the pilot's seat. The aircraft had a loaded weight of 4295 lbs. (1950 kg) and was designed for a maximum speed of 498 mph (640 Km/h) at sea level.

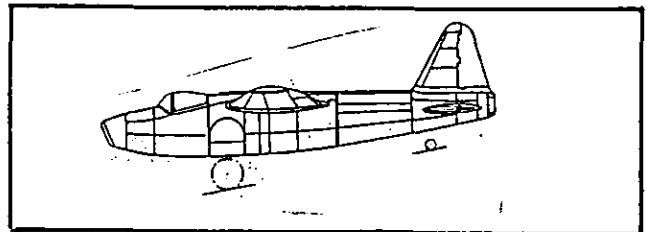

Figure 10. The He 178- World's first jet powered aircraft.

On August 27, 1939, the He 178 piloted by Erich Warsitz made a historic 6 minute flight from the Heinkel airfield in Marienehe at about 4 am. There was great jubilation after this historic event. Heinkel rushed to inform the RLM of this achievement, but met with indifference as the RLM had more immediate problems of gearing up for the war which was to start within a few days. Later, Heinkel arranged for a demonstration of the He 178 that

was observed by Schelp, Milch and Udet. The aircraft experienced a fuel pump leakage problem initially prior to takeoff and Heinkel had to improvise by claiming a tire blow out to keep the skeptical group interested while the fuel pump was replaced (Jones, 1989). Finally, a successful demonstration was made, but there was little enthusiasm displayed by the Air Ministry representatives.

This was the first aircraft in the world to fly utilizing a turbojet and was also the first to experience a bird ingestion problem<sup>17</sup>. To put the date into perspective, the first flight was one year before the Caproni-Campini CC2<sup>18</sup> and 20 months before the British Gloster E28/39 first took to the air with Whittle's W1 engine.

## 5. THE HeS 6 ENGINE.

The HeS 6 was a refinement of the HeS 3 engine with increased thrust up to 1,300 lbs at 13,300 rpm. The specific fuel consumption was essentially the same as the HeS 3. While this engine itself was successful, the combination of the HeS 6 within the He 178 airframe resulted in poor performance. Problems with the airframe and a persistent problem wherein the undercarriage would not retract finally caused Heinkel to retire the He 178 which was moved to the Air Museum in Berlin and subsequently destroyed during an Allied bombing raid.

## 6. ENGINE DEVELOPMENT FOR THE He 280 JET FIGHTER

Shortly after the demonstration of the He 178 to the RLM, Heinkel started development of a twin engine fighter which was designated the He 280. The aircraft could not use engines of the HeS 3B type because of the large engine diameter and low performance. At this time, however, the axial flow engine (designated the HeS 30) that was being developed by Mueller who had arrived at the Heinkel Rostock plant, was experiencing serious development problems. Recognizing that this engine would not be ready in time, von Ohain made a gamble in designing a back up solution designated the HeS8 which would employ a radial rotor similar to the HeS 3B combined with an axial vane diffuser and a straight through flow combustor. Only 14 months were available for this development, as the He 280 airframe was developed much faster than its engines.

It is interesting to examine the history of the Mueller engine in context of von Ohain's work. Mueller had his initial contacts with Heinkel and Dr. von Ohain in early 1939 when he offered to bring Heinkel the Wagner engine and the project team. At this time, Mueller gave the impression that the engine program was well advanced and Heinkel and von Ohain believed that this program together with their own He S 3 engine would place Heinkel in a leading position as a jet engine maker. Mueller and his team were hired by Heinkel and came over in the summer of 1939. The Wagner engine took on the Heinkel designation of HeS 30. Mueller and his team were incorporated in Dr von Ohain's propulsion group and given the task to finalize the development of the HeS 30. Dr. von Ohain and Heinkel soon realized that this engine program was nowhere near the advanced stage, implied by Mueller. Heinkel pushed hard for the effort to make this program successful especially as the HeS 30 was to be the propulsion plant for Heinkel He 280 fighter. During contract negotiations with the RLM, Udet, who was supportive of Heinkel and who had recognized that Heinkel needed engine manufacturing capability and skilled manufacturing manpower to compete with the established engine companies, made Heinkel a gentlemen's agreement that if the He 280 succeeded in flying before April 1941 Heinkel could buy the Hirth Motoren company in Stuttgart.

<sup>17</sup> Luckily this was a small bird and did not pose a problem.

<sup>18</sup> This aircraft used a ducted fan jet system but utilized a reciprocating compressor and consequently was not a true turbojet.

By the end of 1939 the HeS 30 progress was very slow and Heinkel, concerned of the adverse impact on the He 280 program, approached Dr. von Ohain to develop a backup solution. Dr. von Ohain's solution, designated the HeS 8A, was a design based on the HeS 3B but with an axial diffuser and a straight through flow combustor. The engine program was done under a RLM contract giving the engine the first RLM designation of a German turbojet the 109-001. It was not without risks because the specification of the aircraft limited the engine diameter and therefore the axial diffuser function and efficiency together with the straight through combustor became very critical. Luckily for Heinkel, von Ohain's HeS 8 engine managed to meet the minimum requirements and was ready in time for the first flight of the He 280 which took place in late March 1941. The He S 30 program still suffered several problems including a mismatch between the compressor and turbine. Thus, it is thanks to von Ohain's HeS 8 that the He 280 flew on schedule and the RLM allowed Heinkel to purchase Hirth Motoren company which could then give the Mueller team support with the HeS 30 program.

## 7. THE HeS 8A ENGINE DESCRIPTION

The HeS8 (RLM Designation 109-001) was designed with the specific objectives mentioned above and was based on the HeS 3 and HeS 6 engines. The reduction in diameter was accomplished by redesign of the compressor diffuser into an axial design and combustion chamber, by making it a "straight through" design as shown in Figure 11. The leading particulars of this engine are shown in Table 1

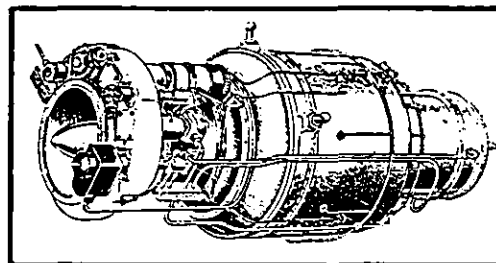

Figure 11. The HeS 8 engine.

PARAMETER	HESS8 ENGINE
RPM	13,500
Weight	837 lbs. (380 kg)
Frontal Area	5.05 sq. ft. (0.47 m <sup>2</sup> )
Specific Thrust.	1.89Lb thrust/Lbs. (18.5 N/kg)
Specific fuel consumption	1.6 Lbs/Lbs thrust hour;(0.163 kg/Nh)

Table 1. Leading Particulars of the HeS 8 Turbojet.

The HeS 8A comprised of a 14-blade axial flow inducer having airfoil type blades, which were made from aluminum alloy forgings. The inducer was followed by a 19-vane radial flow impeller of composite construction consisting of aluminum alloy blades retained in a steel hub and rear shrouding plate. Leaving the combustor, the working fluid passed through a 14-blade radial inflow turbine, also built up of steel blades retained in a steel hub. The compressor-turbine shaft was mounted on two bearings, one between the inducer and impeller and the second aft of the turbine.

The combustion chamber was a "straight through" annular design with compressor discharge passing through two sets of diffuser vanes prior to entering the combustor. The vaporizing fuel system injected fuel into the chamber through 16 sets of eight nozzles giving a total of 128 nozzles. Each nozzle was a tube approximately 1/16<sup>th</sup> inch in diameter. Initially, no attempts were made to provide any secondary air distribution but later models had such provisions.



The propelling nozzle was of fixed area and a tailpipe was used on the He 280 installation. The exact number of engines of this type actually built is not known but several versions were built.

Even though the HeS 8A was a good engine, its power was marginal for the He 280, and it lost out to the Jumo 004, which had been chosen for the production of the Me 262 jet fighter. While the performance in terms of thrust and fuel consumption and length was superior<sup>19</sup>, the HeS 8A engine also had a problem relating to the radial inflow turbine which represented a technology leap for the time and the overall need for strategic materials was higher than for the axial cooled blading of the Jumo 004. Consequently, thrust growth by means of increasing turbine inlet temperature was limited for the HeS 8A without the use of strategic materials such as nickel. The radial inflow turbine blades also suffered from fatigue failures and blade-to-hub attachment problems.

## 8. THE WORLD'S FIRST JET FIGHTER THE He 280

The He 280 was a graceful twin engine fighter designed by Robert Lusser<sup>20</sup>. It was designed as an all metal mid-wing monoplane powered by two turbojets located in nacelles under the wings. The wing had a straight leading edge and then a dihedral outboard of the engines. The tail consisted of a high mounted tailplane carrying a fin and rudder on each tip. The latest variant had a V tail. Nose armament consisted of three 20-mm cannon. The aircraft had a wingspan of 40 ft (12 m) and a length of 34 ft (10.04 m).

The He 280 was itself a revolutionary design in that it had a tricycle undercarriage and a compressed air-operated ejection seat. By March 1941, the first experimental aircraft V1 had made 40 gliding flights and on March 30, 1941 it took off for the first time powered by von Ohain's HeS 8 Engines with Heinkel's test Pilot Fritz Schaffer at the controls. No engine cowlings were fitted for this flight due to fuel leakage which was noticed prior to the flight. On April 5, 1941, the aircraft was successfully demonstrated in front of RLM officials. The He 280 was also flown in test combat against a Focke Wolfe 190.

There is an interesting anecdote on the He 280 reported in Jones (1989). Just before a take-off, test pilot Bader, was handed a small hammer by Robert Lusser. Lusser, explained to Bader apologetically that there was as yet no means of jettisoning the cockpit canopy and that should he have to leave in an emergency, he would need the hammer to smash his way out. The He 280 is shown in Figure 12.

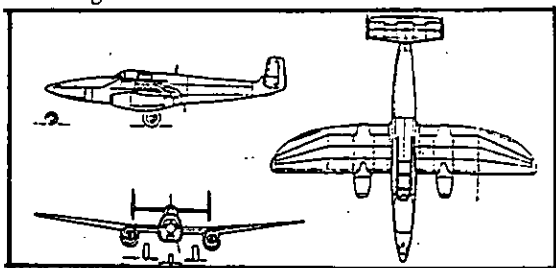

Figure 12. The graceful twin engine He 280 jet fighter powered by von Ohain's HeS 8 engines.

## 9. ACQUISITION OF HIRTH MOTOREN AND FORMATION OF HEINKEL HIRTH

Working at Heinkel gave von Ohain complete technical freedom and the ability to choose his own path with constraints related to funding or test facilities or interference by the RLM.

<sup>19</sup> The axial flow Jumo 004 was, however, superior to the HeS8A in thrust per unit projected frontal area.

<sup>20</sup> Heinkel had hired Robert Lusser away from Messerschmitt. Lusser had done preliminary design work on the ME 262.

Further, he had the direct and enthusiastic support of the owner of the company. This was an excellent environment for innovation for the early engines but as the needs turned to production, the disadvantages of working for an airframe company began to show. There was a lack of expertise in the area of engine design in the areas of materials, blading vibrations, aeromechanics, manufacturing techniques. Heinkel wished to buy an engine manufacturer to enhance his position as an engine company and to derive the required technical manpower.

After the demonstration flight of the He 280, Heinkel finally received permission to purchase Hirth -Motoren<sup>21</sup> which was a reputable manufacturer of reciprocating aero engines and turbochargers located at Zuffenhausen near Stuttgart. This acquisition was fraught with politics, with Heinkel's rival Messerschmitt reportedly delaying the acquisition for several months<sup>22</sup>. With the acquisition of Hirth, Heinkel had access to the engineering capabilities and manufacturing know-how of this small but well known engine company.

The formal name of the company formed when Heinkel took over Hirth Motoren was Ernst Heinkel AG-Werk Hirth Motoren and was called Heinkel-Hirth for short. It is interesting to note that when asked during a conference in 1978 what single item von Ohain would have asked for during his early development days, he stated that the greatest need was for expertise in the area of blade vibrations which he said he got from the Hirth Company in the form of Dr. Bentele<sup>23</sup> (An Encounter Between the Jet Engine Inventors, 1978).

After the acquisition of Hirth, Heinkel started moving his jet engine team to Zuffenhausen. Mueller and his HeS 30 axial flow engine being the first to arrive in the Fall of 1941. Shortly thereafter in 1942, Von Ohain and his propulsion team also relocated to the Heinkel-Hirth facilities. Von Ohain immediately struck up an excellent working relationship with the Hirth engineers and the combined team worked closely in engine development. Von Ohain's brilliance, modesty and fairness immediately caused a bond to develop between the Hirth engineers. Mueller on the other hand, was not receptive to help for his problematic HeS 30 axial flow machine (Bentele, 1991). The HeS 8 engine was in the stage where it was being developed for manufacture and Hirth engineers contributed towards this task. In July 1942, the HeS 8A was running well, but by this time the Me 262 and its Junkers 004 engines had been chosen to be the first production jet for the Luftwaffe. Ultimately, the HeS 8 program, the HeS 30 program, and the He 280 fighter aircraft were officially cancelled in early 1943. Shelp of the RLM decided that von Ohain's team at Heinkel-Hirth should start work on a second-generation turbojet the HeS 011. At this juncture, Heinkel, who in the early years of the war had a pre-eminent position in turbojet engine and jet aircraft technology, had now lost his dominant position<sup>24</sup>.

## 10. DESIGN AND DEVELOPMENT OF THE HEINKEL-HIRTH HeS 011 ENGINE

In 1942 the RLM granted Heinkel-Hirth the contract for a second-generation engine known as the HeS 011 (RLM designation 109-011) which provided a quantum step in specific

<sup>21</sup> Hirth-Motoren GmbH was owned by Hellmuth Hirth and was founded in 1931. Hirth himself died in 1938.

<sup>22</sup> Heinkel's friend Udet in the Luftwaffe had by now realized that the Luftwaffe could not maintain parity with allied air development and a radical technological innovation was called for. Udet committed suicide in 1941.

<sup>23</sup> Dr. Max Bentele was at time, a leading expert in Germany specializing in aeromechanics and blade vibration. In the Fall of 1943, he had resolved a complex blade failure problem on the Junkers Jumo 004 engine.

<sup>24</sup> Unlike Udet, Milch was not as supportive of Heinkel and was disappointed in Heinkel's problems relating to the He 177 long range bomber. This aircraft was a disaster because of absurd requirements imposed on it by the RLM. Further, political lobbies in Berlin resented Heinkel's free-wheeling style.



power and performance. The specifications of this engine were (Bentele, 1991):

Max thrust 2863 lbs (12.75 kN) with a growth to 3307 lbs (14.7 kN), weight under 1985 lbs (900 kg), pressure ratio 4.2:1, altitude capability 50,000 ft (15 km), specific fuel consumption less than 1.4 lb/lb-hr.

Dr. von Ohain was in charge of the development and Dr. Max Bentele was responsible for component development and managed the development on the compressor and turbine sections of the engine.

As reported by Bentele (1991), in December 1944 the best performance parameters attained for the engine were a thrust of 2940 lb (13kN) at a rotor speed of 10,205 RPM. The leading particulars of the first generation Jumo 004B engine which was in production and this advanced engine developed at Heinkel-Hirth are compared in Table 2. A photograph of the engine is shown in Figure 13 (Bentele 1991) and the layout depicted in Figure 14(Neville and Silsbee, 1948).

Parameter	Jumo 004 B	HeS-011A
Manufacturer	Junkers Engine	Heinkel-Hirth
Thrust, Lbs	2000; (8.927 kN)	2863 ; (12.75 kN)
Weight, Lbs	1650; (750 kg)	1950; (885 kg)
T/W Ratio	1.21	1.44
Length	152" (3860 mm)	131.6" (3343 mm)
Frontal dia.	30"; (760 mm)	32";(805 mm)
Air mass flow rate, lb/sec	46.7; (21.2 kg/sec)	64; (29 kg/sec)
Pressure Ratio	3.1:1	4.2:1
RPM	8700	10,205
Compressor configuration	8 stage axial flow	Diagonal stage +3 axial stages
Turbine Configuration	1 stage turbine	2 stage air cooled
Fuel Consumption Lb/Lb thrust	1.4-1.48	1.35
Turbine inlet temperature, F	1427F;(775C)	1427 F (775C)

Table 2: Comparison between the Junkers Jumo 004B and the Heinkel Hirth HeS 011 engines.

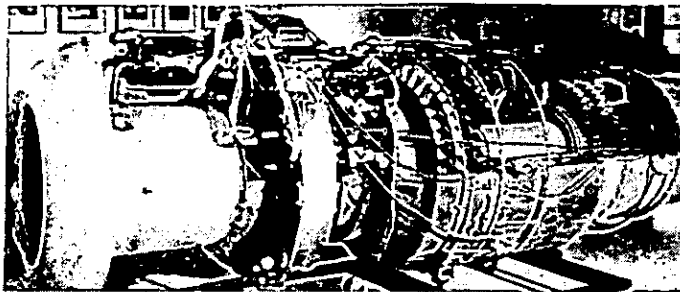

Figure 13. The Heinkel Hirth HeS 011 Engine

### 10.1 Compressor Section.

The concept and aerodynamic design of the compressor was by Dr. von Ohain. The compressor had a single stage inducer row followed by a diagonal compressor<sup>25</sup> (mixed flow) stage and then three symmetric (50% reaction) axial flow compressor stages. As the air exited the first axial inducer stage, the annular passage was reduced by a shaft fairing to the diagonal compressor. The combination of a diagonal stage with axial flow stages was ingenious as it made the operating line very flat and

<sup>25</sup> This was called "kombination sverdichter."

imparted growth potential without incorporating variable geometry which would be required for higher pressure ratios.

The double-skinned intake hoods served the dual function of straightening the airflow and housing the accessories, oil tank and lube oil pump. Both warm air and electric heating were available for anti-icing. A photograph of the compressor section is shown in Figure 15 which shows the mixed flow stage.

To develop this compressor, a 1600 kW electric test stand in Zuffenhausen and a steam turbine driven 15,000 hp stand in Dresden were utilized. The rigs allowed the measurement of flow, pressure and temperature distributions in the flow path and considerable challenges had to be met in designing the mixed flow compressor section. Rather than arriving at an optimal configuration for the axial stages analytically, this was done experimentally using adjustable stators. A variety of settings were tested on the stand and finally this led to satisfactory performance as shown in the compressor map of Figure 16 (Bentele, 1991). Bentele recounts that during one test, in spite of smooth running of the engine, the occurrence of discrepancies in pressure and temperature readings puzzled the test team. The issue was resolved when a technician appeared with some broken aluminum blades which he had found at the compressor air exit and inquired if this might be the problem! Evidently, the uniform breakage of the blades did not result in significant unbalance.

### 10.2 Combustor

The combustor was an annular design with airflow being divided into two flow streams by an annular headpiece with a small airflow being routed into the head piece for mixture preparation and combustion. Most of the air was routed through two of the outer and inner rows of vented at the end of the combustion chamber and into the missing chamber to attain the required temperature. The housing wall located around the combustor was protected against radiant heat transfer by an annular insulator around which was circulated fresh air from the chamber. Sixteen equispaced fuel nozzles were utilized with four igniter plugs, two on the lateral axis and two 45 degrees upwards. Bentele indicated that the combustor was a great design challenge and obtaining a satisfactory radial and circumferential temperature profile was not easy given the flow profile emanating from the mixed flow compressor wheel. The combustor was, therefore, a design compromise but one that worked.

### 10.3 Turbine Section

The HeS 011 had a really remarkable two stage air-cooled turbine section (Figure 17) designed by Dr. Max Bentele. Two rows of hollow turbine nozzle blades were cooled by air bled off through the annulus after the final compressor stage. This nozzle cooling air was ducted between the combustion chamber and the rotor shaft, which was shielded by an annular insert. The two-stage axial turbine was cooled by compressor bleed air. Both of the discs had hollow vanes with air being routed to the second stage through holes bored in the first stage. The airflow exited the blades at the tip.

The development of the turbine section was most challenging. Initially solid blades were employed and stress rupture occurred at the first stage and fatigue failures at the second stage. The resonance failure was traced to the location of 4 struts of the rear bearing support and these were eliminated by spacing the struts at unequal angles thus minimizing the forced excitations which were in resonance with the second-stage rotor blades. Some of the strut arrangements analyzed are shown in Figure 18. A Bentele Diagram<sup>26</sup> of the blading is depicted in Figure 19. (Hirth-Motoren report, January 1944).

The final air-cooled blade designed by Dr. Bentele did not utilize any strategic materials and were called "topfschaufel." These blades were manufactured starting with a circular plate of austenetic chrome-moly steel from which a closed end tube was drawn in several stages with intermediate heat treatments. As seen in Figure 20 (Hirth-Motoren Report, April 1944), wall thickness diminished from 0.079 in (2 mm) at the root to 0.017 in

<sup>26</sup> Bentele developed this diagram independent of knowledge of Campbell's work on steam turbine blade vibration in the USA.

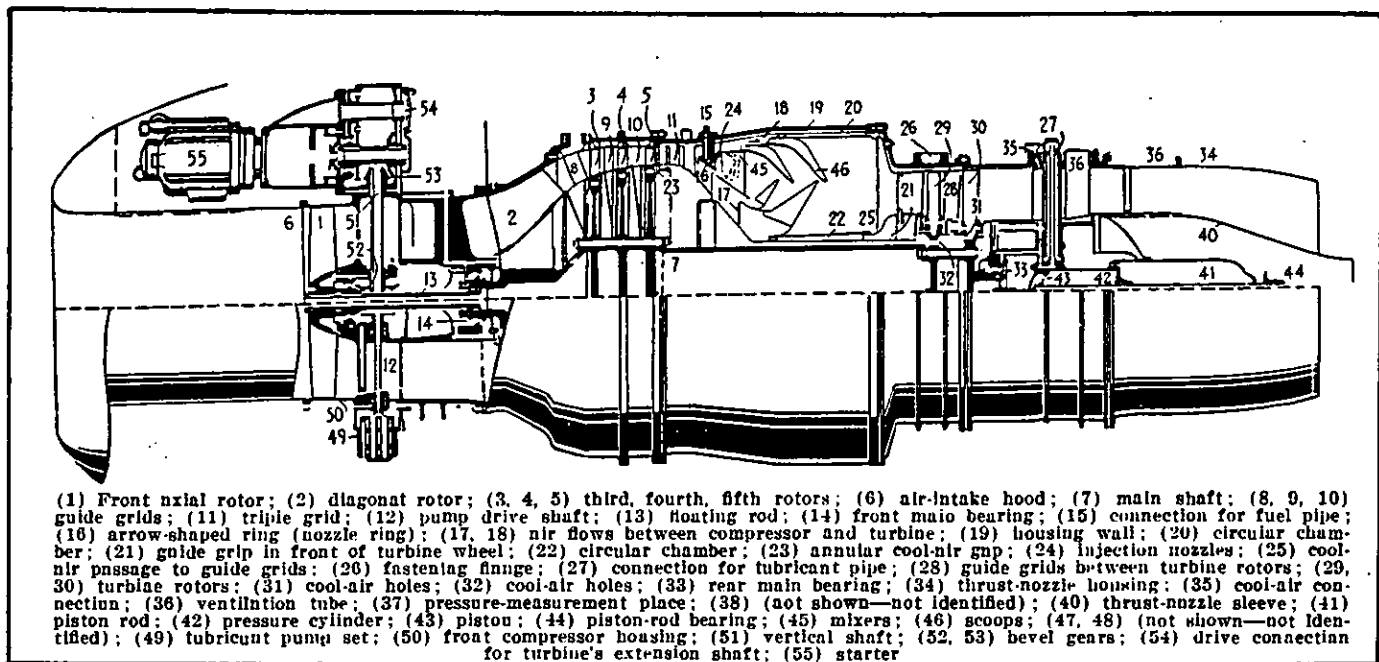

Figure 14. Layout of the advanced HeS 011 engine (Neville and Silsbee, 1948).

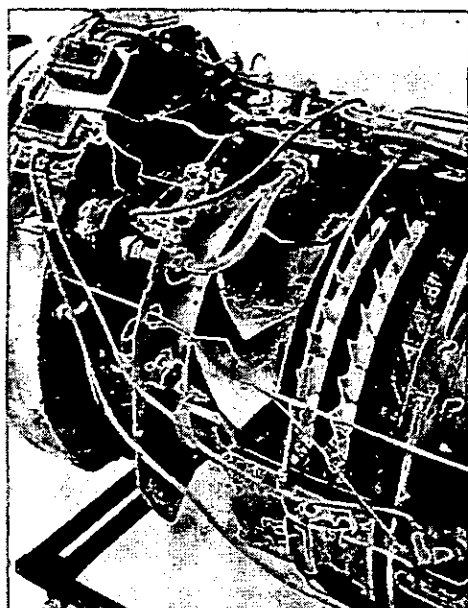

Figure 15. Compressor section of the HeS 011 (Bentele 1991)

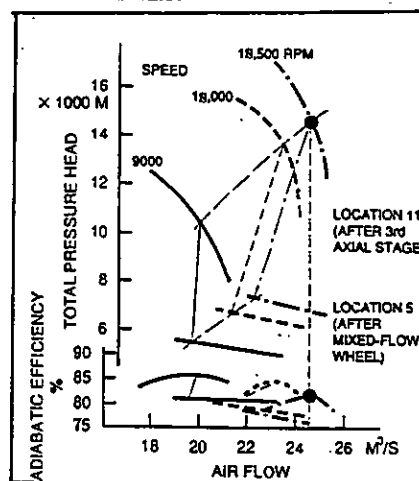

Figure 16. HeS 011 Compressor Map (Bentele, 1991)



Figure 17. Details of the HeS 011 2 stage air cooled turbine section (Bentele, 1991).

(0.45 mm) at the blade tip, so as to match the stresses with the prevailing radial temperature profile. The airfoil shape was then induced and finish machining done. Both the first and second turbine stages utilized this construction and contained an insert for the proper distribution of the cooling air and for damping blade vibration.

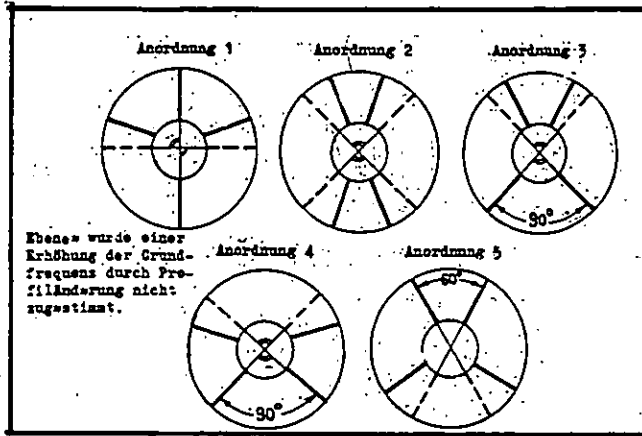

Figure 18. Some rear bearing support strut arrangements evaluated in resolving blade vibration problem

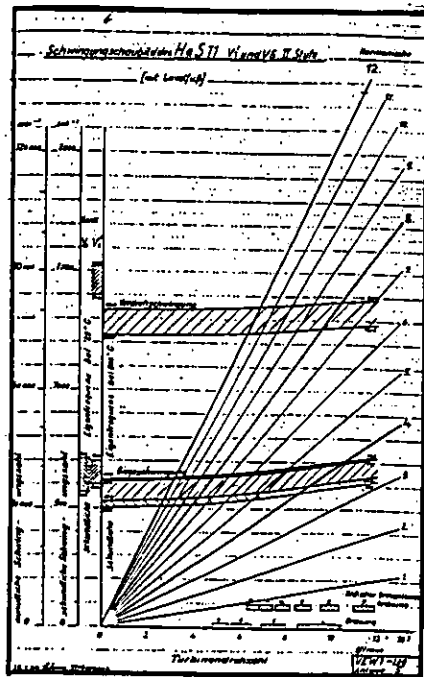

Figure 19. Bentele Diagram showing excitation and natural frequencies (Hirth Motoren Report, Jan 1944).

### 10.4 Mechanical Features and Accessories

**10.4.1 Bearings and Accessories.** There were two main bearings on the HeS 011. The front main ball bearing was located just ahead of the diagonal compressor and was both a radial and thrust bearing. A floating shaft extended from it to drive the front axial compressor and, via bevel gearing and vertical take off shafts, the accessories. Accessories located above the engine

included the Riedel starter<sup>27</sup>, a Siemens or Bosch generator, a Barmag fuel pump, Knorr air compressor and tachometer. The rear bearing located aft of the 2 stage turbine was cooled as well as lubricated by pressurized oil.

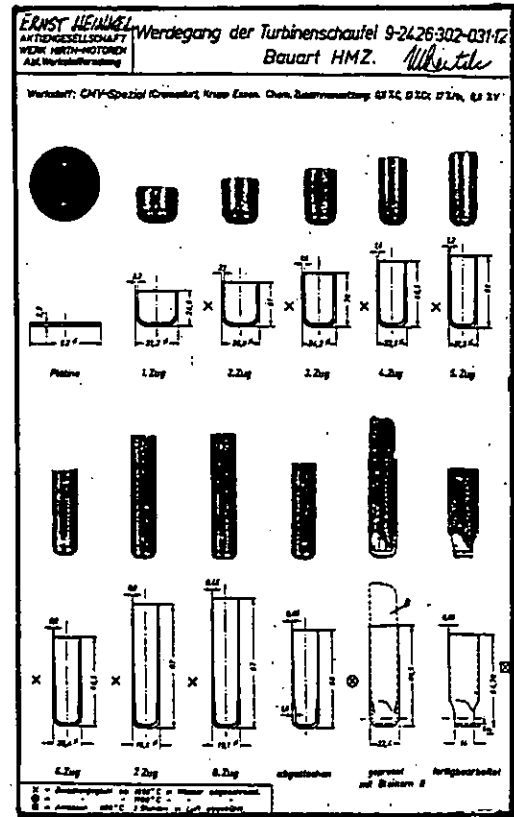

Figure 20. Ingenious method of developing air cooled turbine blade starting with a circular plate 25 mm dia.

**10.4.2 Fuel System.** The fuel system was controlled by the throttle, which operated a constant speed governor to control fuel and thus engine speed. Fuel was routed to a low-pressure fuel pump which was a double gear pump with two independent suctions. The delivery of this pump was fed to the Barmag high-pressure fuel pump, which delivered about 13.7 gpm (51.6 l/min) at a pressure of 570 psi (40 kg/cm<sup>2</sup>). A pressure control valve diverted excess flow back to the suction side of the low-pressure pump. The high-pressure fuel was then fed to the governor and through two annular pipes to the 16 fuel injectors in the combustor. A pressure valve on the delivery pipes ensured that the appropriate pressure to sustain operation would be admitted to the combustor.

**10.4.3 Lubrication System.** Lube oil tanks with a capacity of 3.18 gal (12 liters) were located on the lower part of the accessory support on both sides of the pumpset which consisted of a delivery and 2 scavenge units. An additional return (scavenge) pump was located behind the rear bearing. The oil flow rate was 9.24 gpm (35 L/min) at an operating pressure of 50-57 psi (3.5-4 kg/cm<sup>2</sup>). Oil was gravity fed from the tanks to the delivery pump, which routed it through a filter and collector. Both the two main bearings and the accessory bearings were lubricated by the pressurized collector through two distributor pipes. The gearing and bearings of the front axial compressor

<sup>27</sup> This was similar to the starter used in the Junkers Jumo 004 and BMW 003 engines.

were centrifugally lubricated while the bevel gears were spray lubricated.

**10.4.4 Tail Cone Bullet.** The HeS 011 had an adjustable tail cone bullet moved by a piston within the cone<sup>28</sup>. In the original configuration, the bullet was linked to the throttle control to control the piston feed and drain pressure oil pipe. This was later changed to an electrically controllable crossfeed valve connected so that when switched off, it moved to the operating or extended position and when switched on, brought the bullet to the retracted position for startup.

## 11. HANS VON OHAIN, CO-INVENTOR OF THE TURBOJET

Dr. Hans Joachim Pabst Von Ohain was born on December 14, 1911 in Dessau Germany. He received his Doctorate in Physics and Applied Mechanics in 1935 at the University of Göttingen and remained at the University for a year while he developed a theory of jet engines and built a demonstration model. In April 1936, he joined the Heinkel company in Rostock moving to the Heinkel-Hirth company in Stuttgart in the Fall of 1942. He directed a research and development program that resulted in the HeS 3B engine that powered the Heinkel He 178 which made the world's first turbojet powered flight on August 27 1939 at the Heinkel Airfield near Rostock. He also developed the HeS 8A, which powered the world's first twin jet fighter, the He280 that flew in April 1941. Thereafter, he was instrumental, along with Dr. Max Bentele, in the development of what would be the world's most powerful and sophisticated turbojet at the end of the Second World War, the HeS 011.

Being considered one of the most outstanding engineers in Germany in the field of turbojet engineering, Dr. von Ohain was invited to the US in 1947, where he became a research scientist at Wright-Patterson AFB. In 1963, he rose to the position of Chief Scientist in the Air Force Aerospace Research Laboratories, which conducted virtually all Air Force in-house basic research in the physical and engineering sciences. In 1975 he became Chief Scientist of the Aero Propulsion Laboratory, assuming responsibility for maintaining the technical quality of Air Force research and development in air-breathing propulsion, power and petrochemicals.

Dr. von Ohain's accomplishments in these positions won national and international recognition. He retired from government service in 1979 and became Research Professor in Aerothermodynamics at the University of Dayton Research Institute and also a Visiting Professor at the University of Florida. He was immensely popular with his students and always interested in helping young people with their education.

Dr. Hans von Ohain was a man of great humility and modesty. Throughout his life and in his many lectures and papers covering early turbojet history, he always made it a point to mention the contributions of others at times understating his contributions.

During his 32 years of service in the United States, Dr. von Ohain published more than 30 technical papers and registered 19 U.S. patents. He had registered over 50 patents while working for Heinkel. Dr von Ohain was honored for his contributions to aviation with many awards which include the election to member of Deutsche Akademie der Luftfahrt Forschung," the coveted Goddard Award for the American Institute of Aeronautics and Astronautics (AIAA) and numerous Air Force awards. He received the ASME Tom Sawyer Award in June 1990 and was inducted into the National Hall of Fame for Aviation in 1990. Von Ohain and Sir Frank Whittle were awarded the Charles Draper Prize in 1992 for their monumental contributions to aviation. This coveted award is considered the "Nobel Prize" for technology. He was awarded three honorary Doctorates from the Universities of Dayton, West Virginia and University of Florida. He was the recipient of several prestigious German Awards including the Prandtl Ring for his contributions to jet aviation.

<sup>28</sup> Similar to the BMW 003 engine.

Dr. von Ohain passed away at the age of 86 in Melbourne Florida and will forever be remembered as the co-inventor of the turbojet and developer of the world's first flight jet engine.

A photograph of Dr. von Ohain, Sir Frank Whittle and Dr. Max Bentele (Bentele, 1991) is shown in Figure 21. This is the last known photograph of these jet pioneers together and was taken in 1978.



Figure 21. Photograph of three jet engine pioneers taken in 1978. Left to right- Sir Frank Whittle, Dr Hans von Ohain and Dr. Max Bentele (Bentele, 1991)

## 12. CLOSURE

This paper has covered the pioneering work of Dr. Hans von Ohain, co-inventor of the turbojet and a man who changed the future of flight and brought us into the jet age. His seminal work at Heinkel provided the impetus for the jet engine programs in Germany. The paper has covered his historic engines including the HeS 3B world's first turbojet to fly, the HeS 8 which was to power the graceful He 280 fighter and the world's most advanced turbojet at the end of the Second World War, the HeS 011. Notwithstanding his subsequent contributions to jet engine technology through the 1980s, he will always be remembered and will go down in history as a pioneer who made possible the turbojet revolution.

### Acknowledgments

We are grateful to Dr. Max Bentele for his help and communications and for providing us his papers on the subject. His excellent autobiography "Engine Revolutions" covers several interesting details of the dawn of the jet age in which he played a major role and which has been a valuable reference. We acknowledge the help at the American Heritage Center in providing archival data from Dr. Bentele's archives and also the archival staff at the Smithsonian Institute's National Air and Space Museum. The excellent works of Bentele, Constant, Jones and Gunston are recommended to those wishing to pursue this topic further.

## REFERENCES

- "An Encounter Between the Jet Engine Inventors Sir Frank Whittle and Dr. Hans von Ohain", (1978), Wright-Patterson Air Force Base, Ohio, History Office, Aeronautical Systems Division, US Air Force Systems Command.
- "Basic Technical Data on the 109-011 Jet Engine A-O Development Series." Navy Department Bureau of Aeronautics, Third Edition, December 1944.
- "Design of the German 109-011 A-O Turbojet, Aviation, September, 1946.
- Bamford, L.P., Robinson, S.T. (1945), "Turbine Engine Activity at Ernst Heinkel Aktiengesellschaft Werk Hirth-Motoren, Stuttgart/Zuffenhausen," Report by the Combined Intelligence Objectives Sub-committee dated May 1945.
- Bentele, M., (1988) Memorial talk presented in the Engineers Club of Dayton on April 3, 1988, in honor of Dr. Hans von Ohain.
- Bentele, M., (1989) "Das Heinkel-Hirth Turbostrahltriebwerk He S 011- Vorgänger, charakteristische Merkmale, Erkenntnisse" Paper Published in 50 Jahre Turbostrahlflug, DGLR Publication 89-05, October 26-27 1989.
- Bentele, M., (1991) "Engine Revolutions: The Autobiography of Max Bentele," Society of Automotive Engineers, 1991.
- Boyne, W., Lopez, D., (editors), (1979) "The Jet Age: 40 Years of Jet Aviation," Smithsonian Institute, Washington, 1979.
- Carter, J.L. (1945), "Ernst Heinkel Jet Engines," Aeronautical Engine Laboratory(AEL), Naval Air Experimental Station, Bureau of Aeronautics, US Navy, June 1945
- Constant, E.W., II, (1980) "The Origins of the Turbojet Revolution," John Hopkins Univ. Press, 1980.
- Gunston, B., (1995), "The Development of Jet and Turbine Aero Engines," Patrick Stephens, Ltd., UK, 1995.
- Gunston, B., (1995), "World Encyclopedia of Aero Engines," Patrick Stephens, Ltd., UK, 1995.
- Heinkel, E. (1956) "Stormy Life- Memoirs of a Pioneer of the Air Age," E.P. Dutton and Co. NY 1956
- Isby, D.C., (1997) "Fighter Combat in the Jet Age," Harper Collins Publisher, UK.
- Jones, G., (1989) "The Birth of Jet Powered Flight," Methuen, London, 1989.
- Meher-Homji, C.B. (1998), "The Development of the Whittle Turbojet," Transactions of the ASME Journal of Engineering for Gas Turbines and Power, Volume 120, No 2. Paper presented at 1997 International Gas Turbine and Aeroengine Congress, Orlando, Florida, June 2-5, 1997.
- Meher-Homji, C.B., (1997), "The Development of the Junkers Jumo 004B - the World's First Production Turbojet," Transactions of the ASME Journal of Engineering for Gas Turbines and Power Volume 119, No. 4, October 1997 presented at 1996 ASME Gas Turbine and Aeroengine Conference, Birmingham, UK, June 10-13, 1996. ASME Paper No 96-GT-457.
- Neville, L.E., Silsbee, N.F., (1948) "Jet Propulsion Progress," Mc Graw Hill Inc, 1948.
- Schlaifer, R., (1950) "Development of Aircraft Engines," Graduate School of Business Administration, Harvard University, Boston, 1950.
- Scott, P., (1995) "Birth of the Jet Engine," Mechanical Engineering, January 1995, pp 66-71.
- Smith, J.R., and Kay A.L., (1972) "German Aircraft of the Second World War," Putnam Press, UK.
- Von Ohain, H., (1986) "The Beginnings of Jet Propulsion," Tenth Anniversary Historical Symposium, Deputy for Propulsion, Wright-Patterson AFB, September 4, 1986, pp 23-29.
- Von Ohain, H. (1989) Talk made at the 50<sup>th</sup> Anniversary of Jet Powered Flight, Video cassette Volume No 1, AIAA Dayton Chapter.
- Von Ohain, H., (1979), "The Evolution and Future of Aero Propulsion Systems," The Jet Age- 40 Years of Jet Aviation, Ed. Walter J. Boyne and Donald S. Lopez, Smithsonian Institution.
- Hirth Motoren G.m.b.H. Report (1944) VEW 1-139, "Schwingungsuntersuchungen an der He S 11- Turbine V1 and V 6 mit Vollschaukeln," dated Jan 31, 1944; Max Bentele Papers, American Heritage Center, University of Wyoming.
- Hirth Motoren G.m.b.H. Report (1944B) VEW 1-140, "Untersuchung der Fussbefestigung von Topf- und Falt-schaukeln durch Kaltschleuderprüfung," dated April 16, 1944; Max Bentele Papers, American Heritage Center, University of Wyoming.