

**IMPROVING FOOTWEAR OPTIONS FOR PERSONS WITH LOWER LIMB AMPUTATIONS**

**Eric Nickel<sup>1</sup>, Gregory Voss, Billie Slater**  
Minneapolis VA Health Care System  
Minneapolis, MN, USA

**Emily Mueller, Andrew Hansen**  
Minneapolis VA Health Care System and University  
of Minnesota  
Minneapolis, MN, USA

**ABSTRACT**

*Men and women with lower limb amputations struggle with managing the balance between prosthesis alignment and shoe heel rise. A novel prosthetic ankle-foot system is being developed to support a wider range of footwear options for men and women with lower limb amputations. Each rigid foot is customized to fit the footwear of choice and can be rapidly attached to (or released from) an ankle unit which remains attached to the prosthesis.*

*The ankle unit has a mass of 318g and is small enough to fit in the design volume of a 22cm foot across a range of heel rises. The ankle uses elastomeric bumpers arranged in a wiper design to maximize space efficiency.*

*Structural testing has shown that the 3D printed custom Nylon 12 feet withstood 4584N of forefoot loading without failure based on the ISO 10328 loading parameters, indicating suitable strength to support safe human use in the laboratory. The feet have a mass of 446g.*

*Feedback from two women Veterans with lower limb amputations reinforced the importance of improving access to shoes with different heel rises. Future activities will include cyclic fatigue testing, additional weight reduction, and incorporating suggested design refinements.*

Keywords: Prosthesis, footwear, heel-height.

**NOMENCLATURE**

SACH      Solid-ankle cushion heel prosthetic foot

**1.0 INTRODUCTION**

Prosthetists are keenly aware of how their patients often struggle to find footwear that can work with their prosthetic foot.

According to Kapp and Ferguson, “Heel height is the single most important factor in shoe fit related to [prosthetic] foot function.” [1]. These struggles affect both men and women with lower limb amputation, impacting individuals who wish to wear stiletto heels and cowboy boots alike. Understanding the barriers this population faces requires an understanding of the able-bodied biomechanics of adaptation to footwear heel rise and a clear picture of the ability of current prosthetic components to adapt to footwear with different heel rises.

The heel height of a shoe is the measurement from the floor to the top of the heel platform (underside of the shoe upper at the heel). Many shoe styles also have a thickness of shoe sole beneath the forefoot, thus the more relevant metric for human biomechanics is heel rise, the difference between the height of the heel and the height of the forefoot. Healthy able-bodied persons primarily accommodate the heel rise of their footwear at the ankle, increasing plantarflexion at the ankle as the heel rise increases [2,3]. Wearing shoes with higher heel rise moves the plantar pressure anterior from the heel and midfoot to the forefoot and toe region [4]. Furthermore, the toes counterrotate as the ankle plantarflexes to provide a firm base that is generally parallel to the sole of the shoe.

For persons with lower limb amputations, these biomechanical adaptations are not available (Fig. 1). Traditional prosthetic ankle-foot systems (e.g. SACH or VariFlex) are non-adaptive. Accommodation to footwear is achieved through modification of the prosthesis alignment by a certified prosthetist. This alignment is sensitive to the heel rise of footwear [5].

Some modern prosthetic ankle-foot systems possess a passive range of motion, generally achieved through hydraulic damping (e.g. Echelon, Kinterra, Odyssey), that allows for a limited accommodation. The accommodation range of motion is usually only a few degrees of plantarflexion and/or dorsiflexion, allowing for accommodation of minor slopes or

<sup>1</sup> Contact author: [Eric.Nickel@va.gov](mailto:Eric.Nickel@va.gov).

limited tolerance of footwear with different heel rises. One challenge of these products is that the hydraulic damping range of motion results in an inherent loss of energy because that displacement is not recovered during unloading leading to reduced energy return relative to traditional non-accommodating feet of similar design.



**FIGURE 1:** A PROSTHETIC FOOT ALIGNED FOR ONE PARTICULAR HEEL RISE (LEFT) IS INHERENTLY MISALIGNED WHEN WEARING SHOES OF OTHER HEEL RISES, AS DEMONSTRATED BY THE ANGLE OF THE RESPECTIVE PYLONS (CENTER, RIGHT).

There are also some prosthetic ankle-foot systems that allow the user to adapt the alignment to accommodate footwear of different heel rises (e.g. Accent, Runway). These systems lock into place for walking, avoiding the inherent energy losses of the passive damping range of motion systems, but these systems rely on the user being able to achieve a suitable alignment. Failure to accommodate correctly to new footwear is equivalent to walking on a mis-aligned prosthesis and can lead to the same skin health problems (including blisters, sores, pain, etc.) which can in turn result in otherwise avoidable medical costs and reduced participation during healing. Many prosthesis users have comorbidities that impact cognitive function and/or sensation, introducing further challenges to achieving a successful self-alignment.

Reducing the need for manual adjustment, advanced robotic prosthetic ankle-foot systems (e.g. Proprio, emPOWER) can make the small adjustments automatically, but many prosthesis users do not qualify for microprocessor-controlled prostheses and these systems have other challenges such as dramatically increased cost, batteries that require recharging, greater mass, and increased maintenance. For many patients who do qualify for microprocessor-controlled feet, these challenges outweigh the benefits.

In addition to the categorical challenges faced by the different types of prosthetic feet, no prosthetic foot currently on the market alters its plantar surface to match footwear as the heel rise increases. For lower heel rise, the plantar surface of a prosthesis can conform to the interior of a shoe because the toes are generally curved upward slightly and are more flexible than the rest of the foot (often the toes are not supported by the keel, but rather they are flexible foam features of the surrounding cosmetic foot cover). As the heel rise increases, the midfoot takes on a steeper angle, but the toe region remains generally parallel to the sole of the shoe. The shape can be readily modeled by a

modified Witch of Agnesi formula [5]. At low heel rise, the difference between a normal prosthetic foot and the footwear may be unnoticeable to a casual bystander, but at greater heel rises, e.g. above five centimeters, the difference becomes evident, as demonstrated by a prototype system developed at Johns Hopkins [6]. Furthermore, many prosthetists provide feet that are undersized relative to the patient's anatomical foot for the purpose of aiding in inserting and removing the prosthetic foot from the shoe when switching footwear (such as when arriving at home and removing their shoes).

An alternative approach to the problem of adapting the prosthesis to fit different footwear was developed by Price [7]. Price's system used traditional SACH feet with different heel rises and custom-made shims such that each foot was correctly aligned with its intended footwear. The challenge of this system is that the connecting bolt that attached the feet to the prosthesis was located under the heel in the bottom of the foot, such that removing the foot required first removing the footwear and then using a wrench to unbolt the foot. The time required to switch feet made this approach less practical from a daily-wear perspective, but patients were happy to have the option to wear stylish footwear when they wished. Furthermore, the custom shims required extensive labor and shaping by the prosthetist, increasing the amount of time required in the clinic. Finally, SACH feet are known to be a low-functioning style of foot.

An ideal prosthetic ankle-foot system would resolve many of the identified barriers to selecting the user's footwear of choice. First, it would be capable of supporting a wide array of foot sizes and shapes (wide and narrow foot shapes, blunt and pointed toe boxes, etc.) to approximate the size, shape and appearance of the contralateral foot. It would also be capable of supporting very high heel rises if desired, up to 10cm and possibly more, while conforming to the plantar surface of the footwear. It should not generate a struggle every time the user wishes to don or doff their shoes, with access from the top such that shoes need not be removed to switch feet. And lastly, it should enable dynamic energy storage and return, like higher functioning prosthetic feet on the market. The option for additional cosmetic features, such as sandal toe (ability to support sandal straps between toes) could further augment the user's satisfaction with their appearance but are beyond the scope of early exploratory development.

## 2.0 PROPOSED SOLUTION

The rise of 3D printing has led to mass customization in healthcare, where patient matched solutions are nearly as easy to generate as generic solutions. In terms of prosthetic feet, the geometry of the foot must be customized to the shape of the shoe, but the walking function must remain constant. The roll-over function of the human ankle-foot complex remains invariant under a wide array of conditions including load carriage, walking speed, and changes in heel height (albeit at a different neutral angle at the ankle) [2,5,8-11].

Many high-heeled shoes have inflexible keel structures that preclude generating a roll-over through flexing of a keel

structure throughout the foot length (as is the case with traditional carbon-fiber energy-storage-and-return prosthetic feet), thus a system suitable for use over a broad array of heel heights should incorporate the ankle-foot roll-over mechanics primarily at the ankle. In the present work we propose to follow in the spirit of the system developed by Price in developing an ankle-foot system where a single ankle unit containing the majority of the ankle-foot function is easily inserted into, and removed from, custom-shaped prosthetic foot structural keels designed to fit individual shoes (Fig. 2). The prosthetist can align the ankle unit in any of the feet (with appropriate shoes) and that alignment should transfer to all other feet with their respective shoes.

With the mechanical and manufacturing complexity contained within the ankle unit (retained with the prosthesis), the foot structure can be low cost and be purchased with the appropriate plantar configuration for each pair of shoes. The requisite foot (sans ankle unit) is inserted into the appropriate shoe and, once settled in place, can remain there as long as desired. When the wearer wishes to don or doff the shoe, they also don or doff the custom-fit foot, with an accessible connector.



**FIGURE 2:** THE NOVEL ENDOSKELETAL ANKLE UNIT WITH A STANDARD 10MM HEEL RISE FOOT. A SINGLE SET SCREW AT THE TOP OF THE HEEL LOCKS THE ANKLE UNIT INTO THE FOOT.

The ankle unit fits within a socket in the foot and is locked on by tightening a single set screw. The set screw is located at the top of the heel. The ankle unit and the socket within the foot are closely matched in shape with a light draft (taper) such that the foot is able to slide off without binding when not loaded, but

under load the forces and moments cause the ankle unit to remain firmly seated without movement. Under walking conditions, the only purpose of the set screw is to prevent the foot from falling off the ankle unit when unloaded, such as during the swing phase of walking.

With digital customization, the system can achieve equivalent alignment across a broad range of heel rises (Fig. 3).



**FIGURE 3:** THE NOVEL ANKLE UNIT QUALITATIVELY DEMONSTRATES ALIGNMENT EQUIVALENCE WITH CUSTOMIZED FEET. BOTH ANKLE UNITS ARE WITHIN 1 DEGREE OF LEVEL.

### 3.0 ANKLE UNIT DESIGN AND TESTING

The ankle design volume was the common (intersection) space between the two extreme foot heel rises of 22cm SACH prosthetic feet (10mm heel rise and 89 mm heel rise). Use of 22cm feet to define the design volume supports developing feet for shoes as small as women's size 5 (US). The feet were scanned and overlaid in Geomagic Freeform (3dsystems, Rock Hill, SC). The intersecting volume was used as the design volume.

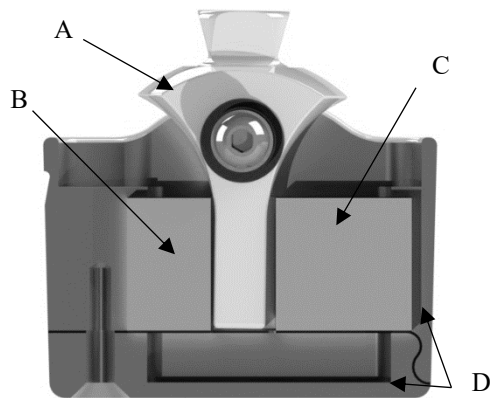

**FIGURE 4:** THE NOVEL ENDOSKELETAL ANKLE UNIT.

Using the available design volume as a hard constraint, a single axis ankle element (Fig. 4) was designed to fit in a housing that could be dropped into a mating cavity in the rigid prosthetic

foot element. The housing was machined out of 6061-T6 aluminum alloy to minimize weight at a reasonable cost point. The ankle system housing was designed with 5° drafted exterior surfaces on all sides to allow for easy insertion and release from the prosthetic foot. The ankle housing is widest at the anterior surface to distribute forefoot loads into as wide an area as possible. The total mass of the ankle system is 318 g.

To keep the system within the volumetric design constraints, the elastomeric bumpers were oriented horizontally, in a wiper-style design. The cross section view in Fig. 5 shows the internal features of the ankle system. The pyramid adapter was built into a wiper element (A) to reduce weight and part count. Titanium, 6AL-4V, was chosen for the wiper element due to the high cyclic loading that the wiper is exposed to. The dorsiflexion bumper (B) is smaller than the plantarflexion bumper (C) due to the higher stiffness requirement during dorsiflexion and the greater range of motion desired during plantarflexion. This design provides over 20 degrees of plantarflexion rotation and 15 degrees of dorsiflexion rotation from neutral. Figure 5 also shows that the housing (D) has a two-part construction, allowing access to the bumpers from underneath the unit, with a single screw to hold the housing assembly together.



**FIGURE 5:** SECTION VIEW OF THE UNIT. THE PYRAMID WIPER (A) COMPRESSES THE DORSIFLEXION AND PLANTARFLEXION ELASTOMERIC BUMPERS (B AND C RESPECTIVELY) AS IT ROTATES.

#### 4.0 FOOT DESIGN AND TESTING

The customized feet were printed on a Stratasys Fortus 400mc 3d printer and were made of Nylon 12. The foot was designed in SolidWorks (Dessault Systemes Solidworks Corporation, Waltham MA) as a Boolean merging of multiple bodies: a plantar plate, internal structure, external shell, and ankle receiver socket (Fig. 6). This foot had a mass of 446g when printed.

The internal structure included a central oval, centered approximately 25% of the foot length from the heel, that provided a solid volume from which to subtract the ankle receiver socket and radiating ribs that extended to the external shell. One main rib extended from the anterior aspect of the central oval toward the big toe, providing reinforcement for the full length of the foot. Other anterior ribs described arcs that

joined with the main rib to further support the forefoot against mediolateral loading. The external shell was 1mm in thickness to provide a smooth surface for cosmetic purposes but was not intended to provide structural support. The ankle receiver socket was subtracted from the central oval of the internal structure and was designed to match the external geometry of the ankle unit with a small amount of clearance to avoid binding.



**FIGURE 6:** CUT-WAY RENDERING OF THE MULTI-BODY DIGITAL FOOT MODEL, SHOWING THE INTERNAL STRUCTURE, EXTERNAL SHELL, AND ANKLE RECEIVER SOCKET.

The worst-case foot for structural testing is the “flattie”, a foot with essentially zero heel rise, because the moments are maximized in late stance phase with this heel rise. Structural strength was assessed by subjecting a printed foot to external loads based on the ISO 10328 ultimate strength test. The foot withstood a peak load of 4584N without failing, at which point our test machine was unable to apply further load due to limited facility air pressure, maintaining that force for more than 10s. This force exceeds the lower threshold of the ultimate strength test for the P8 load level (4450N, applicable for persons with a body mass up to 175kg) and exceeds the upper threshold of the ultimate strength test for the P5 load level (4480N, applicable for persons with a body mass up to 100kg). The structure exhibited limited flexion and no permanent deformation during testing, indicating further loading is possible.

#### 5.0 STAKEHOLDER INTERVIEWS

Two women Veterans who use lower limb prostheses provided key guidance regarding future directions for this project in individual unstructured interviews. Oversight was provided by the IRB at the Minneapolis VA Health Care System. The participants provided informed consent. Both Veterans, upon seeing a demonstration of the prototype system, expressed excitement, liking the ability to switch shoes without needing to doff the prosthesis or remove the shoe from the prosthetic foot. One of the Veterans expressed an interest in wearing stiletto heels and expressed a desire to be able to change shoes daily during the summer time if she had the option to wear sandals, regular shoes, and heels for going out. The other Veteran

described the ability to change shoes without taking the feet out of the shoes as the “coolest thing ever.”

One Veteran also requested the retention mechanism be located on the medial aspect to improve access and allow switching of feet without doffing the prosthesis. The other Veteran requested that the retention mechanism be cosmetically covered to avoid interrupting the appearance of the system.

One of the Veterans described her experience using a heel-height adjustable prosthetic foot currently on the market:

“When I have to adjust my ankle, I usually have to do it two to three times, otherwise it is cutting into my knee or something. If it is even a hair off...”

Together, this preliminary feedback has been positive and encouraging of further development. Next steps are to:

- 1) Optimize the structure of the ankle unit to reduce mass
- 2) Optimize the internal structure of the foot to reduce mass
- 3) Begin human testing to determine the biomechanical performance of the ankle unit and obtain experiential feedback from prosthesis users.

The current prototype system has demonstrated sufficient structural strength for human subject testing in the laboratory. Further cyclic testing would support future take-home testing of the system.

## ACKNOWLEDGEMENTS

This work was supported by the US Department of Veterans Affairs, Rehabilitation Research and Development Service, Project ID #A2634-R. The views, opinions, and interpretations expressed in this article are those of the authors and do not represent the views of the Department of Veterans Affairs or the United States Government.

## REFERENCES

[1] Kapp, S. L., and Ferguson, J. R., 2004, “Below-Knee Amputation: Prosthetic Management.” *Atlas of Limb*

*Prosthetics and Limb Deficiencies; Surgical, Prosthetic, and Rehabilitation Principles, 3rd Ed*, American Academy of Orthopedic Surgeons.

[2] Choi, H.S., Kim, Y.H., 2007, “Foot/ankle roll-over characteristics in different heel heights during level walking.” *World Congress on Medical Physics and Biomedical Engineering 2006, IFMBE Proceedings*, vol 14, Magjarevic R., Nagel J.H. (eds), Springer, Berlin, Heidelberg

[3] Hansen, A. H., Childress, D. S., 2004, “Effects of shoe heel height on biologic rollover characteristics during walking.” *J Rehabil Res Dev*, 41(4), 547-54.

[4] Hapsari, V. D., Xiong, S., Yang, S., 2014, “High heels on human stability and plantar pressure distribution: Effects of heel height and shoe wearing experience.” *Proc Hum Fact Ergonom S Annual Meeting*, 58, 1653-7.

[5] Meier, M. R., Tucker, K. A., Hansen, A. H., 2014, “Development of inexpensive prosthetic feet for high-heeled shoes using simple shoe insole model,” *J Rehabil Res Dev*, 51(3), 439–50.

[6] McDaniels, A.K., 2016, “Johns Hopkins students create high-heeled prosthetic,” *Washington Post*, August 9, 2016.

[7] Price, A. E., 1991, “Interchangeable feet,” *J Prosthet Orthot*, 3(4), 201-5.

[8] Hansen, A. H., Childress, D. S., 2005, “Effects of adding weight to the torso on roll-over characteristics of walking.” *J Rehabil Res Dev*, 42(3), 381–90.

[9] Hansen, A. H., Childress, D. S., Knox, E. H., 2004, “Roll-over shapes of human locomotor systems: Effects of walking speed.” *Clin Biomech*, 19(4), 407–14.

[10] Hansen, A. H., Childress, D. S., 2010, “Investigations of roll-over shape: Implications for design, alignment, and evaluation of ankle-foot prostheses and orthoses.” *Disabil Rehabil*, 32(26), 2201–9.

[11] Hansen, A. H., Childress, D. S., 2009, “Effects of shoe heel height on the roll-over shapes of prosthetic ankle-foot systems: Implications for heel-height-adjustable components.” *J Prosthet Orthot*, 21(1), 48–54.