



The Society shall not be responsible for statements or opinions advanced in papers or discussion at meetings of the Society or of its Divisions or Sections, or printed in its publications. Discussion is printed only if the paper is published in an ASME Journal. Papers are available from ASME for 15 months after the meeting.

Printed in U.S.A.

Copyright © 1994 by ASME

94-GT-495

EFFERVESCENT ATOMIZERS FOR SMALL GAS TURBINES

LINDA HALL LIBRARY
6100 CHERRY STREET
KANSAS CITY, MO.

Jibao Li and Arthur H. Lefebvre
Purdue University
West Lafayette, Indiana

James R. Rollbuhler
NASA Lewis Research Center
Cleveland, Ohio

ABSTRACT

An experimental investigation is conducted into the potential of effervescent atomizers as fuel injectors for gas turbine engines. The designs studied include three different configurations of multihole effervescent atomizers and an effervescent/airblast hybrid atomizer. In all tests the liquid employed is water. The spray characteristics investigated include drop size distributions and liquid flux distributions within the spray. The results obtained show that multihole effervescent atomizers combine good atomization with uniform liquid flux distribution. This makes them especially suitable for application to annular combustors because they allow appreciable reductions to be made in the number of fuel injectors needed to achieve uniform circumferential fuel distribution. The hybrid atomizer also combines good atomization with the capability of wide cone angles.

The only drawback exhibited by these atomizers is the need for a separate supply of atomizing air. This drawback could restrict their applications to non-aeronautical gas turbine engines.

INTRODUCTION

Previous work on effervescent atomizers has shown that these types of internal-mixing, twin-fluid atomizers have good potential for eliminating some of the problems associated with pressure-swirl and airblast atomizers when these devices are employed as fuel injectors in gas turbine engines. Effervescent atomizers require neither high injection pressures nor large quantities of high-velocity air. Instead, a small amount of air is introduced into the liquid at some point upstream of the atomizer exit orifice in a manner designed to create a bubbly two-phase flow of liquid and air. When this mixture emerges into the relatively low pressure region outside the nozzle, the liquid is disintegrated into droplets by the rapid expansion of the air bubbles. The degree of atomization achieved is governed mainly by the total bubble energy of the spray which, in turn, is largely dependent on the air/liquid ratio and the pressure drop across the exit orifice. An early study on the effervescent atomization of water carried out by Roesler and Lefebvre (1989) showed that SMDs (Sauter mean diameters) as low as $40\ \mu\text{m}$ could be obtained at a pressure drop of 340 kPa (50 psi), using only 0.8 percent of air by mass. Another useful advantage of effervescent atomizers stems from the fact that the liquid and the atomizing air both occupy the same flow passages which, in consequence, have to be made larger in cross section in order to accommodate both fluids. This is a useful asset in combustion applications because these large atomizer flow passages and orifices are less prone to blockage by contaminants in the fuel. Furthermore, the large increase in volume created by the presence of the air in the two-phase flow affords the opportunity to use this additional

bulk as a means of achieving a more uniform distribution of fuel throughout the combustion zone.

With large annular combustors, the problem of achieving a reasonably uniform circumferential distribution of fuel throughout the combustion zone is alleviated by using a large number of fuel injectors. Twenty to twenty-four separate fuel nozzles is typical of many large annular combustors. By this means the spacing between individual fuel nozzles is kept small and all regions of the combustor receive a fairly uniform fuel distribution. However, with small annular combustors the problem of achieving a circumferentially uniform fuel patternation is far more severe. Due to restrictions on the minimum size of flow passages that can be employed, the fuel nozzles used in large combustors cannot be scaled down in size. Consequently, the maximum number of fuel nozzles that can be used in small annular combustors is often around six, and may even be as low as four. A potential advantage of effervescent atomization is that air can be used not only to atomize the fuel, but also to transport the fuel-air mixture around the circumference of the combustor in such a manner that the large voids in fuel concentration which would otherwise exist between adjacent fuel nozzles are eliminated.

The work described in this paper forms part of an on-going research program supported by the NASA-Lewis Research Center, Cleveland, on fuel injectors for small gas turbines.

ATOMIZERS

All types of atomizers have a characteristic dimension which governs the mean drop size in the spray. For diesel injectors and plain-orifice airblast atomizers, the characteristic dimension is the diameter of the discharge orifice. For pressure-swirl and prefilming airblast atomizers, the characteristic dimension for atomization is the initial thickness of the liquid sheet. In general, any reduction in characteristic dimension results in improved atomization. The atomizer shown in Fig. 1 employs effervescent atomization to reduce the characteristic dimension and thereby reduce the mean drop size. Most of the air supplied to the atomizer is used to provide a swirling air flow which serves both to atomize the fuel and to generate a spray of wide cone angle. The remaining air is injected into the fuel to create a bubbly flow at the discharge orifice. The main function of the bubbles is to reduce the characteristic dimension, but their subsequent "explosion" downstream of the nozzle exit further improves atomization by increasing the interaction between the disintegrating fuel ligaments and the swirling air flow.

The effervescent/airblast atomizer described above could be applied to any type of combustor - annular or tubular. Three additional atomizers were designed specifically for annular combustors. The first such atomizer carried the designation A1. Its principal dimensions are shown

in Fig. 2. Had this atomizer been designed to fit into an actual combustor, it would be curved to match the curvature of the combustor. However, in order to simplify the problems of manufacture, it was designed as two concentric straight tubes, as illustrated in Fig. 2. The inner tube which contained the atomizing air was provided with 16 groups of holes, with 3 holes in each group. All 48 holes are 1mm in diameter. The relative juxtaposition of these holes is indicated in Fig. 2. The spacing of 3mm between each group of holes was judged to meet the requirements of a fairly uniform distribution of air into the liquid without having the air injection holes so closely spaced that air bubbles from adjacent holes could coalesce to form large air jets. The air-liquid mixture was discharged from the atomizer through 16 holes. These holes were also made 1mm in diameter. Two additional atomizers,

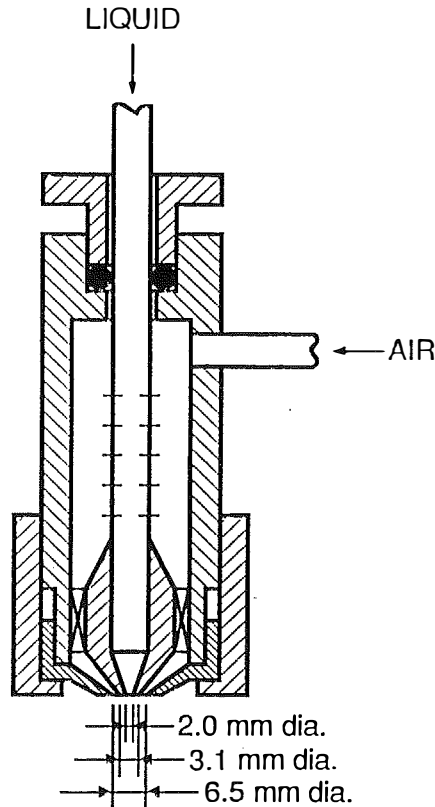

Fig. 1 Effervescent/airblast atomizer.

designated A2 and A3, were also manufactured to investigate the effects of varying the number of discharge orifices on spray characteristics while maintaining a constant orifice diameter. Thus atomizer A2 is identical to atomizer A1 except that the number of discharge orifices is reduced from 16 to 8 and the spacing between adjacent holes is increased from 3mm to 6mm. For atomizer A3 the number of discharge orifices is reduced to 4 while their spacing is increased to 12mm.

In a second series of tests, the number of discharge orifices was kept constant at four, but the size of these holes was varied. Three hole diameters of 1.00, 1.41, and 2.00mm were employed, and these atomizers were designated as B1, B2, and B3, respectively. A cross-sectional view of atomizer B3 is given in Fig. 3.

In the A and B atomizer designs described above, the atomizing air duct is located within the fuel manifold. This design of atomizer could encounter problems with fuels of low thermal stability. For such fuels it is preferable to surround the fuel manifold with flowing air which, in addition to atomizing the fuel, would also serve to reduce the heat transfer from the flame to the fuel within the atomizer. One such design, C1, is illustrated in Fig. 4. This figure shows the fuel pipe located inside the atomizing air duct. Twelve groups of holes, each group consisting of three holes 1mm in diameter, are used to inject air into the fuel tube. The resulting fuel-air mixture is then discharged through four holes of 1.27 mm diameter.

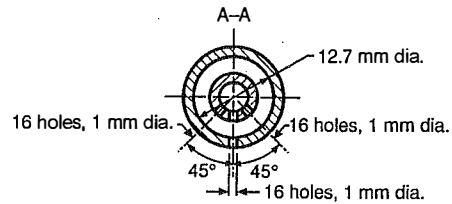
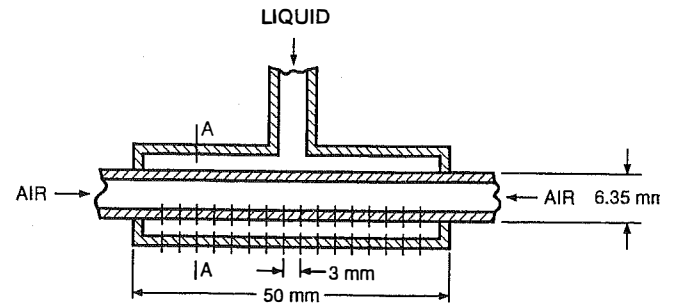

Fig. 2 Cross-sectional view of atomizer A1.

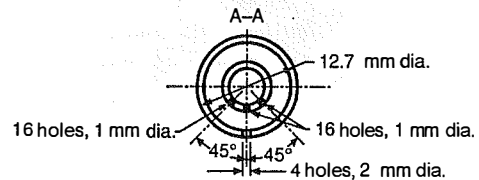
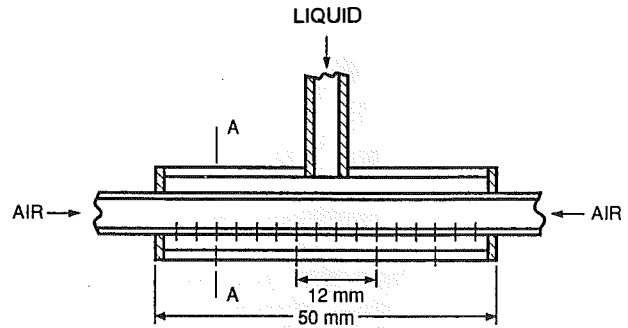

Fig. 3 Cross-sectional view of atomizer B3.

EXPERIMENTAL

As the experimental test facility employed in this study has been described in detail in a number of previous publications (for example, Whitlow and Lefebvre, 1993), only a brief description is given here. In all tests the liquid employed is water. A 930kPa air supply provides both atomizing air and air to pressurize the water storage tank. Pressurized air flows through a Brooks rotameter to two metering valves of different size connected in parallel. The larger valve is used for coarse adjustment of the flow rate and the smaller valve is used for fine adjustment. The air then passes through a ball shut-off valve and flows to the atomizer. All pressures in this study were measured with dial-indicating Bourdon-tube pressure gauges.

A Micro Motion mass flow meter is used to measure liquid flow rates. Liquid flows from the pressurized storage tank through the flow meter and a ball shut-off valve and on to the atomizer. In all tests the atomizer sprays downwards into air at normal atmospheric pressure. An evacuation system is mounted below the atomizer to provide a downdraft of air to reduce the recirculation of fine droplets whose presence in the spray region could cause errors in drop size measurement.

Drop size measurements of the sprays are made using a Malvern Particle Size Analyzer, model 2600, manufactured by Malvern Instruments Ltd. When fitted with a 300mm focal length lens, this well-known instrument allows measurement of drop diameters in the range from 5.8 to 564 μm .

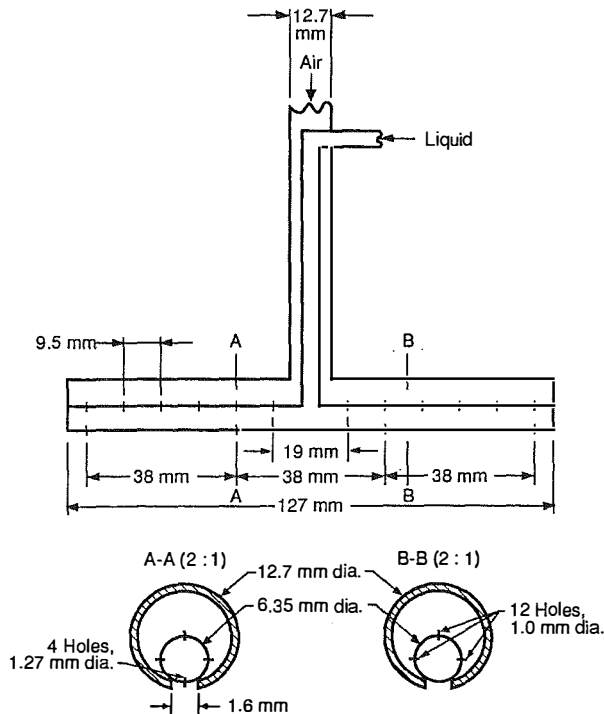

Fig. 4 Cross-sectional view of atomizer C1.

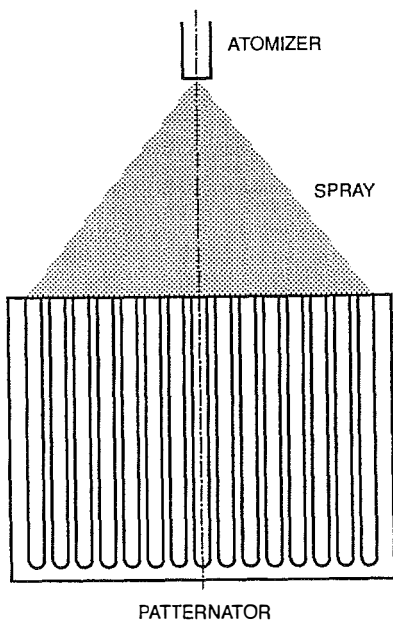

Fig. 5 Patternator for measurement of radial liquid distribution.

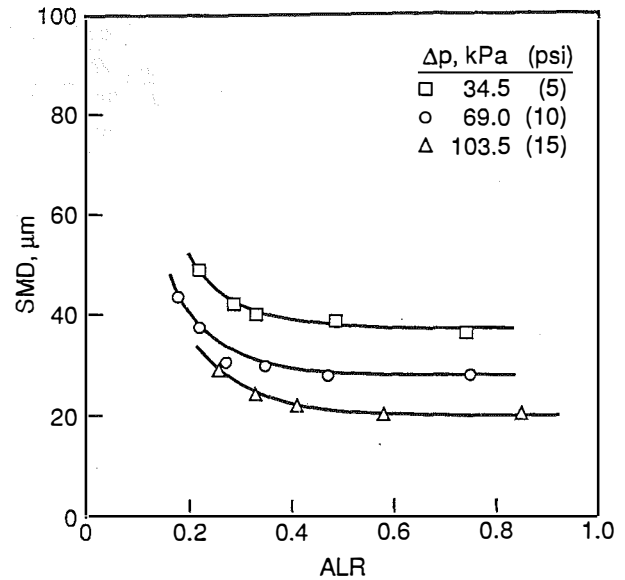

Fig. 6 Drop-size characteristics of effervescent/airblast atomizer.

The distribution of liquid flux along the main axes of the atomizers designated A1, A2, and A3 were measured using a patternator of the type shown schematically in Fig. 5. This patternator is formed by a row of collection tubes which are located below the atomizer and in line with its main axis. The patternator was formed by cutting slots which formed sampling tubes into a flat sheet of metal over which a clear sheet of acrylic (3.2mm thick) is glued. Equal spaced horizontal lines are scribed on the outer wall of the patternator from the bottom of the tubes to the top. These lines permit measurement of the height of the liquid in each tube. As these tubes all have the same cross-sectional area, the height of the liquid in any one tube provides a measure of the liquid flow rate in the spray at that location. When the atomizer attains the desired operating conditions, a cover is removed and the collection tubes start to fill. When one tube is nearly full of liquid the liquid supply to the atomizer is turned off. Steps are taken to ensure that any residual liquid which dribbles from the atomizer after shut-off does not enter the collection tubes.

RESULTS

Some of the drop size data obtained with the effervescent/airblast hybrid atomizer are shown in Fig. 6 in which SMD is plotted against air/liquid ratio (ALR) for three different values of injection pressure, Δp . It should be noted that, as the pressure drop across the holes that feed air into the liquid is quite small (just a few centimetres of water), for all practical purposes Δp represents the difference in the supply pressures of both air and liquid (as measured close to the atomizer) and the ambient air pressure which is normal atmospheric. The results show that mean drop sizes diminish with increases in Δp and/or ALR. This characteristic is typical of most twin-fluid atomizers. The atomization quality achieved with the effervescent/airblast atomizer is quite high, as illustrated in Fig. 6. This figure shows values for SMD of around 20 μm for a Δp of only 103.5kPa (15 psid). If the injection pressure is reduced to 34.5kPa (5 psid) the SMD rises to around 40 μm which may still be regarded as very satisfactory. These low levels of SMD are attributed to the beneficial effect of injecting a small amount of air into the liquid just upstream of the final exit orifice. As mentioned earlier, the competition for space between the air and the liquid as they flow through this orifice causes the liquid to disintegrate into shreds and ligaments before being exposed to the swirling airblast air stream which completes the atomization process by shattering the ligaments into small droplets. Thus the total atomization process may be regarded as taking place in two stages. Stage 1 occurs within the nozzle and represents the conversion of bulk liquid into irregularly-shaped shreds and ligaments at the nozzle exit. Stage 2 of the

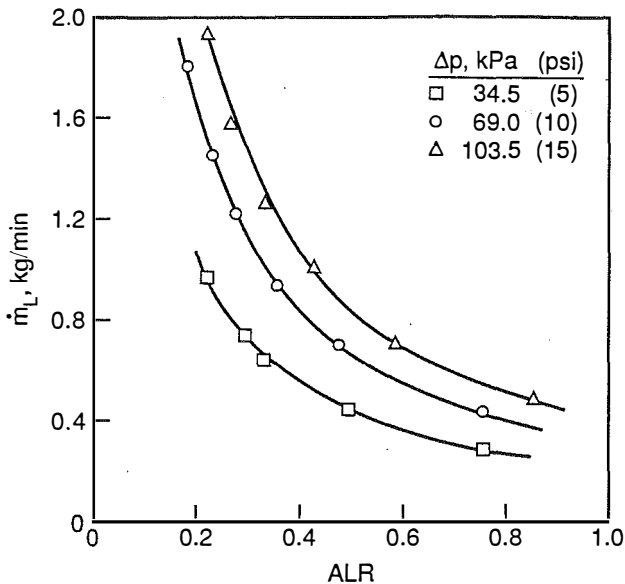

Fig. 7 Liquid flowrate characteristics of effervescent/airblast atomizer.

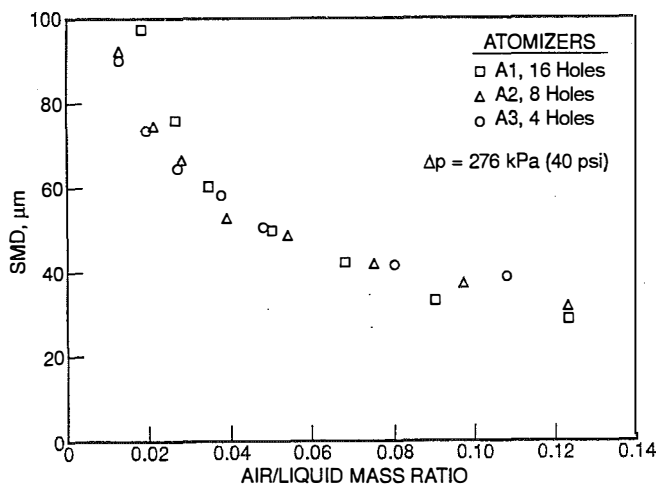

Fig. 8 Influence of number of holes on SMD.

atomization process takes place immediately downstream of the nozzle exit. In this region the rapidly expanding air bubbles in the central portion of the spray cause the ligaments formed in stage 1 to be flung radially outwards into the swirling airblast stream. The radial momentum thereby imparted to the liquid ligaments promotes atomization, partly by increasing the interaction between the liquid and the high-velocity air stream, but also by increasing the relative velocity between the liquid and the atomizing air. In this context it should be noted that in most conventional airblast atomizers the liquid and atomizing air streams are coflowing. This effectively reduces the relative velocity between the two streams with consequent detrimental effect on atomization. A further point to be made in regard to Fig. 6 is that had kerosine or DF2 been employed instead of water the SMD values would have been significantly lower due to the lower surface tensions of these hydrocarbon fuels.

The liquid flow rates obtained with the effervescent/airblast atomizer are shown in Fig. 7 as plots of flow rate, m_L , versus ALR. In this figure it may be observed that, if the air/liquid ratio is increased while maintaining a constant value of Δp , the effect is to reduce the liquid flow rate. This is simply because any additional air serves to displace some of the liquid that would otherwise flow through the discharge orifice. It should be noted that the ALR values quoted in both Figs. 6 and 7 are based on the

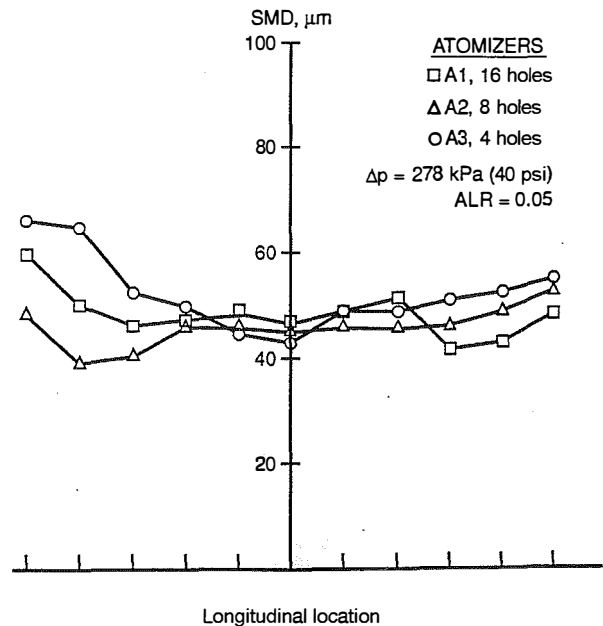

Fig. 9 Longitudinal distributions of SMD.

total air flow supplied to the atomizer which includes both effervescent and swirling airblast air. The breakdown between these two separate air flows could not be measured, but calculations indicate that the amount of air employed in effervescent atomization is less than 10 percent of the total air supplied to the atomizer.

For this type of atomizer the spray cone angle is dictated by the degree of swirl imparted to the atomizing air. This, in turn, is governed by the angle of the swirl vanes located in the airblast air stream. The atomizer used in this study was designed for an included spray angle of 90° . Other spray angles in the range from 60° to 120° may be achieved by suitable selection of swirl vane angle, as with conventional airblast atomizers.

The results obtained with the purely effervescent atomizers designed for small annular combustors are presented in Figs. 8 thru 13. The relationship between SMD and ALR is shown in Fig. 8 for atomizers A1, A2, and A3. These SMD values were obtained by taking several measurements along the main spray axis while maintaining Δp constant at 276kPa (40 psid). These individual SMD readings were then averaged (after suitable "weightings" to accommodate the variations in liquid flux along the atomizer) to obtain the overall SMD for any given values of Δp and ALR.

The manner in which the SMD varies along the longitudinal spray axis is illustrated in Fig. 9. This figure demonstrates that, for a typical ALR of 0.05, the SMD values are fairly constant throughout the spray region. Figure 10 shows the distribution of liquid flux along the main axis of the atomizer for designs A1, A2, and A3. For these tests the values of Δp and ALR were kept constant at 276kPa (40 psid) and 0.05, respectively. Figure 10 demonstrates that for all three atomizers the liquid flux is largest near the center of the atomizer and diminishes with distance from the center. Clearly it would have been possible to vary the sizes and/or spacings of the discharge orifices along the length of the atomizer to achieve an almost uniform longitudinal distribution of liquid flux. This optimization process was not attempted because it was recognized that the results obtained would apply only to the particular atomizer on which it was conducted and would have little relevance to other atomizer designs. Moreover, in an actual engine combustor, these end regions which are deficient in liquid flux would receive additional liquid flux from adjacent atomizers. Nevertheless, an intrinsic asset of this type of multihole effervescent atomizer is that it does lend itself to this kind of treatment which could be used to secure a uniform fuel distribution along the atomizer length at maximum power conditions.

The SMD data obtained with type B atomizers are not reproduced here because they are very similar to the data obtained with the three type A atomizers. The longitudinal variation in liquid flux distribution for

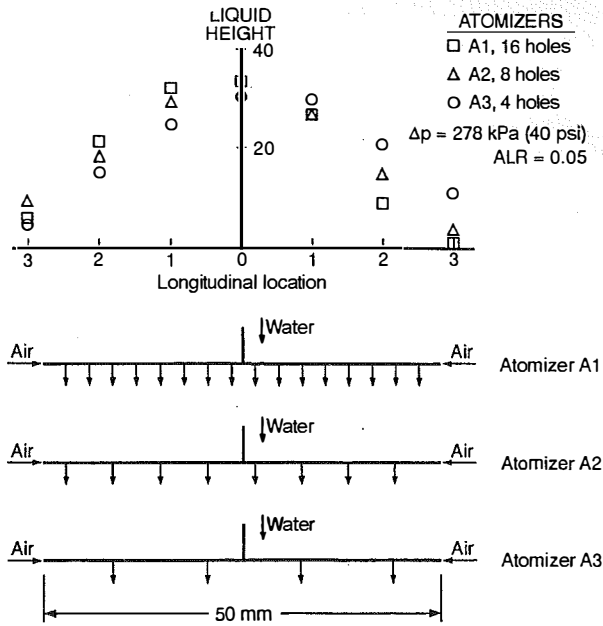

Fig. 10 Longitudinal liquid flux distributions of A type atomizers.

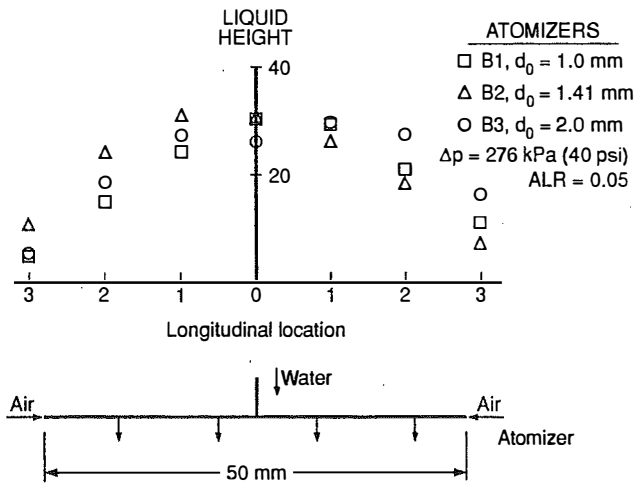

Fig. 11 Longitudinal liquid flux distributions of B type atomizers.

all three atomizers is presented in Fig. 11. This figure shows that the liquid distribution is reasonably uniform and could clearly be further improved by some trimming of hole sizes.

The SMD data obtained with atomizer C1 at different levels of injection pressure and air/liquid ratio are presented in Fig. 12. With this design, the fuel pipe is located within the atomizing air duct, in contrast to designs A and B in which the air supply duct is located along the major axis of the atomizer and is completely surrounded by fuel. Also presented in Fig. 12 are curves showing the relationship between injection pressure, Δp , liquid flow rate, \dot{m}_L , and ALR. The SMD data shown in Fig. 12 are generally consistent with those obtained for atomizers A and B. The general conclusion to be drawn from all the SMD data is that good atomization can be obtained with all three designs and there is no advantage to be gained, at least from an atomization standpoint, in placing the fuel pipe inside the atomizing air duct, or vice versa.

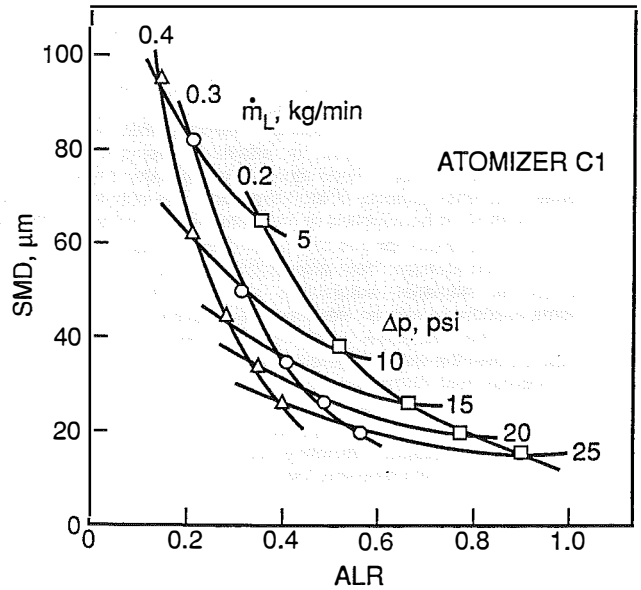

Fig. 12 Relationship between operating conditions and mean drop size.

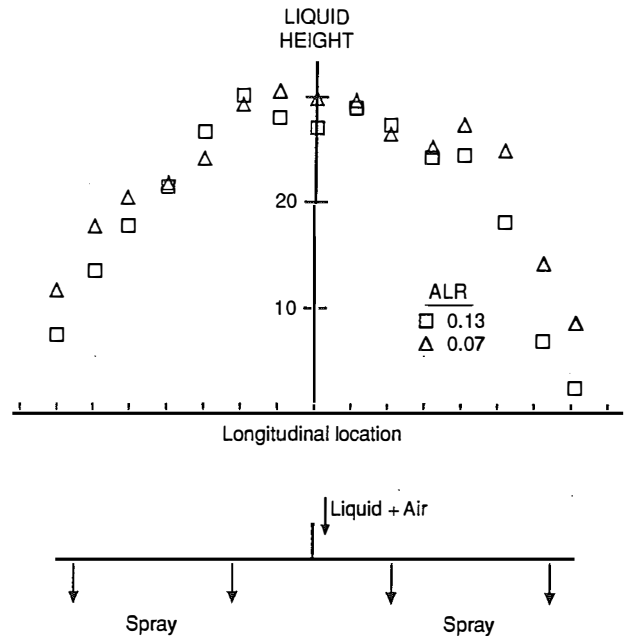

Fig. 13 Longitudinal liquid flux distributions of atomizer C1.

The longitudinal liquid flux distribution for atomizer C1 is illustrated in Fig. 13 for a constant value of Δp of 69 kPa (10psid) and two different values of ALR. Again it is observed that the liquid flux is relatively high and uniform in the central portion of the atomizer and diminishes towards the two ends, and again the comment must be made that these two end regions of low liquid flux would, in an annular combustor, receive additional fuel from adjacent atomizers.

CONCLUSIONS

Tests on several different types of effervescent atomizers, including an effervescent/airblast hybrid design, have shown that the effervescent concept is well suited for applications in small annular gas turbine combustors. The results obtained indicate that a fairly uniform circumferential fuel distribution is attainable using only four to six atomizers per combustor. Good atomization can also be achieved at the expense of a small quantity of atomizing air. The only known drawback is that this air must be supplied at pressures which are above the normal compressor exit values for gas turbine engines. This virtually eliminates the effervescent atomizer from aircraft engines, but it could be a strong contender for industrial, automotive, and marine engines where the problems associated with an external air supply are less formidable. The advantages the multihole effervescent concept offers are good atomization over the entire engine operating range, coupled with uniform circumferential fuel distribution at maximum power conditions. These benefits might fully justify the cost and complication of a small separate air compressor because of the performance advantages to be gained in terms of high combustion efficiency, easy lightup, wide stability limits, good pattern factor, and relatively low pollutant emissions.

REFERENCES

Roesler, T.C. and Lefebvre, A.H., 1989, "Studies on Aerated-Liquid Atomization," *Int. J. of Turbo and Jet Engines*, Vol.6, Nos. 3 and 4, pp. 221-230.

Whitlow, J.D. and Lefebvre, A.H., 1993, "Effervescent Atomizer Operation and Spray Characteristics," *Atomization and Sprays*, Vol. 3, No. 2, pp. 137-156.