

Online monitoring and control of drinking water corrosion potential at a full-scale plant

F. Zraick^{a,*}, C. Cazin^a, S. Bedry^b, M. Andres^b and B. Rabaud^a

^aSUEZ, CIRSEE, 38, rue du Président-Wilson, 78230 Le Pecq, France

^bSUEZ, Water France, 16 place de l'Iris, 92040 Paris La-Défense, France

*Corresponding author. E-mail: flavia.zraick@suez.com

Abstract

To mitigate pipe and water quality degradation in distribution, treatment targets were established to continuously control the corrosion potential of drinking water towards cement, lead and iron materials at a 225 MLD surface water treatment plant. Indicators were identified to estimate the corrosion potential of water for each of the 3 materials: the Langelier Saturation Index (LSI) for cement, pH for lead and a novel corrosion index for iron. Linear Polarization Resistance (LPR) probes equipped with cast iron and lead electrodes provided direct and continuous measurements of actual lead and iron corrosion rates for finished water. Corrosion control was achieved by adjustments to caustic soda doses. The set-point for finished water pH was determined with a site-specific algorithm using online values for temperature, pH, and conductivity as surrogate for calcium and alkalinity. Over the 7 months of implementation, measured iron corrosion rates were maintained well below the established threshold of 50 $\mu\text{m}/\text{year}$. Lead corrosion rates varied from 20 to 40 $\mu\text{m}/\text{year}$ with higher levels occurring when pH dropped below 7.5. The full-scale experience validated a treatment strategy and demonstrated the feasibility of using LPR probes for online monitoring of corrosion potential on drinking water matrices.

Key words: aggressiveness, cast iron, cement, corrosion, distribution pipes, lead, linear polarization resistance

INTRODUCTION

Drinking water quality regulations have historically been defined primarily with human health criteria in mind and seldom incorporate parameters related to the 'health' of pipes and linings in distribution systems. It is nevertheless well established that interactions between water and materials (iron, cement, plastic, lead, copper ...) trigger chemical reactions in the network that can cause the degradation of both water quality (discoloration, turbidity, taste...) and pipes (increased failures and renewal requirements, water losses, decreased delivery capacity from obstruction).

External pipe degradation often triggers pipe failures due to localized conditions of high corrosion related to the geographic heterogeneity of soil environments. Internal corrosion, however, can be the predominant cause of pipe degradation (Rajani & Kleiner 2013; Kinet *et al.* 2018). Furthermore, contrary to external phenomena, internal degradation can be controlled by adjusting the quality of the produced water (Deberry *et al.* 1982; Lassovsky *et al.* 1984; Duranceau *et al.* 2011). As networks age, internal corrosion control becomes increasingly important not only to preserve water quality in distribution but also to extend the remaining service lifetime of pipes.

Systems that do implement corrosion control initiatives often rely on indirect methods using water quality parameters to anticipate corrosion potential and define a treatment strategy (Mirzabeygi *et al.* 2016; Melidis *et al.* 2017; WHO 2017). Surface water treatment plants (WTPs) face a challenge in this

regard due to seasonal and climatic variations in water resources that affect both inlet water quality (temperature, pH, salinity) and chemical treatment requirements (Yang *et al.* 2012). Fluctuations in coagulant and acid doses used to remove suspended particles, algae and organic matter affect water quality parameters such as alkalinity, sulphates and chlorides that in turn have a direct impact on water corrosivity (Shi & Taylor, 2007; Hu *et al.* 2018).

Direct measurements of corrosion rates with Linear Polarization Resistance (LPR) probes is a well acknowledged method of monitoring variations in corrosion levels (AwwaRF 1996; Brossia 2014). In a study relating corrosion of cast iron by drinking water as measured by LPR and by coupon mass loss, the two measures correlated well (Philibert *et al.* 2017). Their implementation is relatively widespread in industrial process water applications but seldom used for corrosion control in drinking water production.

This study presents the results a corrosion control system implemented at a full-scale surface WTP in southern Paris combining both direct and indirect methods to monitor corrosion towards cement, lead and iron materials. Data was collected over a 7-month period covering both cold and warm seasons (January to August).

The Morsang WTP (225 MLD) treats Seine river water with 3 treatment lines composed of clarification by settling followed by ozone oxidation and two stages of granular activated carbon (GAC) filtration. Treated water is combined in a common reservoir ('R4') prior to disinfection with liquid chlorine and final corrosion control with caustic soda.

The plant feeds a 4,500 km distribution network composed of 69% iron pipes (including cement-lined ductile iron), 25% plastic (polyethylene) and 6% cement. Lead connections were almost entirely removed from the public system but this material persists to an uncertain extent in domestic plumbing and therefore remains an issue of health concern. Polyethylene is present mainly in small diameter sections and service connections.

Corrosion control has traditionally been based solely on objectives for the Langelier Saturation Index (LSI) that is widely recognized as relevant for drinking water distribution systems (Plottu-Pecheux *et al.* 2001; Lahav & Birnhack 2007; WHO 2017). Caustic soda doses were adjusted to achieve LSI levels of 0.0–0.3 unless the saturation pH was below 7.3 in which case the target was established as an absolute pH of 7.5 to limit lead corrosion potential. To determine the saturation pH, and hence the target pH, grab samples were taken 1–2 times per week for field lab determination of calcium and alkalinity by titration and application of the Langelier equation (Langelier 1936).

As illustrated in Figure 1, the saturation pH can vary significantly not only over the seasons but also over short periods rendering pH adjustments difficult. Based on water quality data over 2011–2016, actual finished water had an LSI above 0.2 during 68% of the time reflecting an excess consumption of caustic soda estimated at 140 tons per year. At calcium hardness levels observed (170–250 mg/L CaCO₃), an LSI above 0.2 can cause significant scaling issues in domestic plumbing (Pirou 2011; WHO 2017).

In this framework, the primary concern to be addressed in the study was the need to elaborate a treatment strategy for the 3 most critical materials in the Morsang distribution system: cement, iron and lead.

While the LSI is clearly acknowledged as a valid indicator of corrosion potential towards cement, uncertainties persist as to its relevance to anticipate iron corrosion (Sander *et al.* 1997; WHO 2017). In regard to lead control, the minimum pH level of 7.5 is acknowledged in France as relevant for lead control but questions were raised at Morsang on the potential to reduce the threshold to avoid producing scale-forming water when the saturation pH is below 7.3 (24% of the time).

For iron, a variety of corrosion indicators are referenced in the literature but there is no clear consensus on the best option for drinking water networks (Duranceau *et al.* 2011). A pilot study evaluating the relevance of 11 corrosion indices on 20 drinking water matrices indicated that none of the conventional indicators accurately predicted the corrosion potential on cast iron and steel

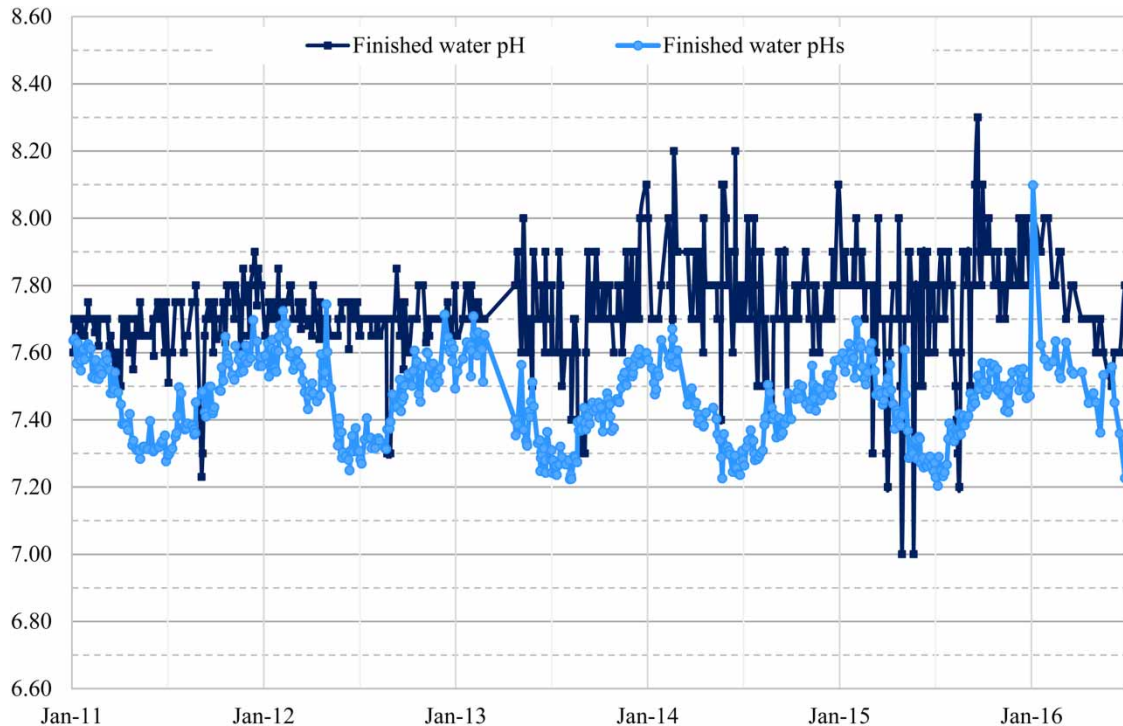

Figure 1 | Actual finished water pH and calculated values of the saturation pH over 2011–2016.

(Philibert *et al.* 2017). Given the importance of this material for water distribution networks and the difficulty to validate relevant water quality indicators, direct measurements appear as an interesting solution for corrosion control.

The corrosion control project was therefore launched with 3 objectives: (i) implement a more accurate LSI control system to protect cement materials while avoiding excess caustic soda consumption and the production of excessively scale forming water; (ii) evaluate the potential to reduce the pH threshold for lead control below 7.5; and (iii) identify a method to effectively monitor corrosion potential towards iron.

MATERIALS AND METHODS

The approach consists of 3 steps: (1) identification of relevant indicators and treatment targets, (2) evaluation of the feasibility of attaining targets with existing caustic soda installation, and (3) definition of treatment strategy and implementation of control solution.

Identification of relevant indicators and treatment targets

A distinct indicator of corrosion potential was identified for each material. The two main criteria for indicator selection were: (i) reliability and (ii) ease of monitoring with online instrumentation.

Cement corrosion control

Aggressive water reacts with cement by a reaction between the aggressive portion of the dissolved CO_2 and the lime present in the cement paste (Soukatchoff *et al.* 2001). Different parameters can be used to measure the aggressive nature of water such as the calculated concentration of aggressive CO_2 , the LSI, the Calcium Carbonate Precipitation Potential or the Aggressiveness Index (Mirzabeygi

et al. 2016). The LSI was selected because this parameter (i) is requested by French regulatory agencies and (ii) has industry-wide recognition as relevant parameter. A target LSI level was established at $+0.15 \pm 0.05$ to obtain a slightly scale-forming water within a range of 0.1 pH units which generally corresponds to the sensitivity of field instrumentation.

Lead corrosion control

Lead occurrence in drinking water is the result of complex phenomena involving various factors including temperature, chemical composition of water and mechanical abrasion (Spencer 2003; WHO 2017). In production operations, water chemistry is the primary means of lead corrosion control. In the absence of specific corrosion inhibitors (phosphate based compounds), the two main parameters of concern are pH and alkalinity (Cuppett 2016). In water matrices with moderate alkalinity, pH alone can be used as indicator of the risk of lead leaching with a min threshold of 8.0 corresponding to a low risk and 7.5 to a moderate to low risk (AGHTM 2000). For this study, the principle of a minimum pH threshold of 7.5 was maintained but the effects of lower pH values were evaluated by a direct measurement of lead corrosion rates.

Iron corrosion control

Water discoloration is not a major issue for the Morsang distribution system and the primary objective of iron corrosion control is to extend the service lifetime of network assets by reducing internal pipe wall degradation rates. The Corrosion Index (CI) proposed by Philibert *et al.* (2017) was selected as indicator for corrosion potential and determined from data on temperature, pH and ionic composition. Recommended interpretation levels are summarized in Table 1.

Review of historic water quality data to evaluate feasibility of corrosion control

The mineral composition of finished water from the Morsang WTP was analysed over 2009–2016 to determine the treatment requirements to reduce water corrosiveness in regard to the selected indicators. This time frame was chosen to account for perceived evolutions in the water resource as reported by operators particularly in terms of observed coagulant requirements.

Raw water quality (Table 2) is characterized by moderate alkalinity and moderate to high hardness. Significant variations in temperature (1–26 °C) and alkalinity (130–230 mg/L CaCO₃) are observed throughout the year. Chloride and sulphate salinity are relatively stable with values that do not vary by more than 15 mg/L CaCO₃ in both cases.

Finished water alkalinity and sulphate levels are affected by the use of aluminium sulphate (alum) in coagulation where doses vary from 50 to 140 mg/L as commercial product namely to manage organics removal. As reference, a 90 mg/L dose of alum lowers alkalinity by 20 mg/L CaCO₃ and increases sulphates by 22 mg/L. In terms of mineral composition, finished water shows an increase in sulphate levels and a decrease in pH both resulting from the coagulation treatment.

Table 1 | Recommended interpretation levels for corrosion index (Philibert *et al.* 2017)

Corrosion Index value	Internal corrosion risk level	Estimated corrosion rate (µm/year)	Estimated service life for cast iron pipe
CI ≤ 2	Low	CR ≤ 50	>80 years
2 < CI ≤ 9	Moderate	50 < CR ≤ 100	80–40 years
9 < CI ≤ 16	High	100 < CR ≤ 150	40–25 years
CI > 16	Very high	CR > 150	<25 years

Table 2 | Historic raw and finished water quality for Morsang WTP (2009–2016)

	Unit	Raw Water				Finished Water			
		Num. values	Ave	Min	Max	Num. values	Ave	Min	Max
Temperature	°C	876	14.6	0.5	25.9	3,158	14.6	1.8	25.9
Conductivity	µS/cm	234	493	384	617	853	512	412	681
pH	–	255	8.0	7.0	8.7	882	7.7	7.0	8.5
Alkalinity	mg/L CaCO ₃	60	189	130	230	1,058	180	130	241
Chlorides	mg/L	237	18.6	10.0	28.0	821	18.8	9.0	32.0
Sulphates	mg/L	225	22.2	14.5	34.7	851	46.6	28.0	161.0
Calcium	mg/L	114	89.9	66.4	108	398	88.4	24.2	103.8
Magnesium	mg/L	114	3.7	2.7	8.0	398	3.7	1.0	14.6
Sodium	mg/L	126	8.9	5.5	12.8	96	14.0	7.3	22.6

Corrosion potential indicators were calculated for treated water over 2011–2016. Produced water LSI was within the optimum range (0.1–0.2) during 16% of the time. Water was aggressive 6% of the time and remaining values correspond to either scale-forming (LSI 0.2–0.3) or excessively scale-forming water (LSI > 0.3).

In regard to lead, 93% of the finished water pH was higher than 7.5 which corresponds to the threshold for moderate to low risk of lead leaching. Only 4% of the values were in the low risk range for lead leaching (pH > 8.0).

Finally, iron corrosion potential as reflected by the CI, was classified as low during 95% of the time. Higher potential was observed with aggressive water (LSI < 0) since the LSI is factored into the CI index. It is therefore anticipated that corrosion rates can be maintained below 50 µm/year (threshold for low level of corrosion).

This analysis demonstrated that is possible to achieve low levels of corrosion potential for cement and iron all of the time with caustic soda doses varying from 1 to 5 mg/L (as pure product) to control finished water pH.

For lead, there is an incompatibility between the low pH threshold to minimize the risk of lead leaching and the established range for the LSI. Raising the pH above 8.0 would imply producing excessively scale-forming water that, given the level of hardness, would likely cause precipitation issues in distribution and in households. To overcome this constraint, a softening treatment would be required.

Definition of treatment strategy and implementation of solution

In view of the mineral composition of the Seine river and the characteristics of the existing treatment line, the following objectives were established for corrosion control of the finished water:

- For cement: Slightly scale-forming water with LSI in the range 0.1–0.2 during 80% of the time and scale-forming water with LSI in the range 0.2–0.3 the remaining 20% of the time
- For lead: Moderate to low risk with a minimum pH threshold of 7.5 during 95% of the time and moderate to high risk with a low pH threshold of 7.3 the remaining 5% of the time
- For iron: CI levels <2 all of the time with measured corrosion rates below 50 µm/year

The solution was operated as a 5-stage process as follows:

- (1) pH, temperature and conductivity measurements are made at the outlet of a the R4 treated water reservoir (20,000 m³) located downstream of the caustic soda injection point by online probes producing data every 15 minutes;

- (2) Values for alkalinity and calcium are estimated from a correlation established between conductivity and these two parameters (Figure 3).
- (3) The saturation pH, or pH_s, is determined by the Langelier equation (Langelier 1936) (i) online data for pH, conductivity and temperature, (ii) calculated values for calcium and alkalinity and (iii) fixed, average values for other ionic species.
- (4) The target finished water pH defined as pH_s +0.15 is determined and displayed as decision aid on local plant SCADA.
- (5) Plant operators adjust the target set-point for treated water pH which regulates caustic soda doses via a control loop. As an indication, for the Morsang water matrix a pH increase of 0.1 units requires approximately 1 mg/L of caustic soda (as pure product).

A schematic of the implemented system is illustrated in Figure 2.

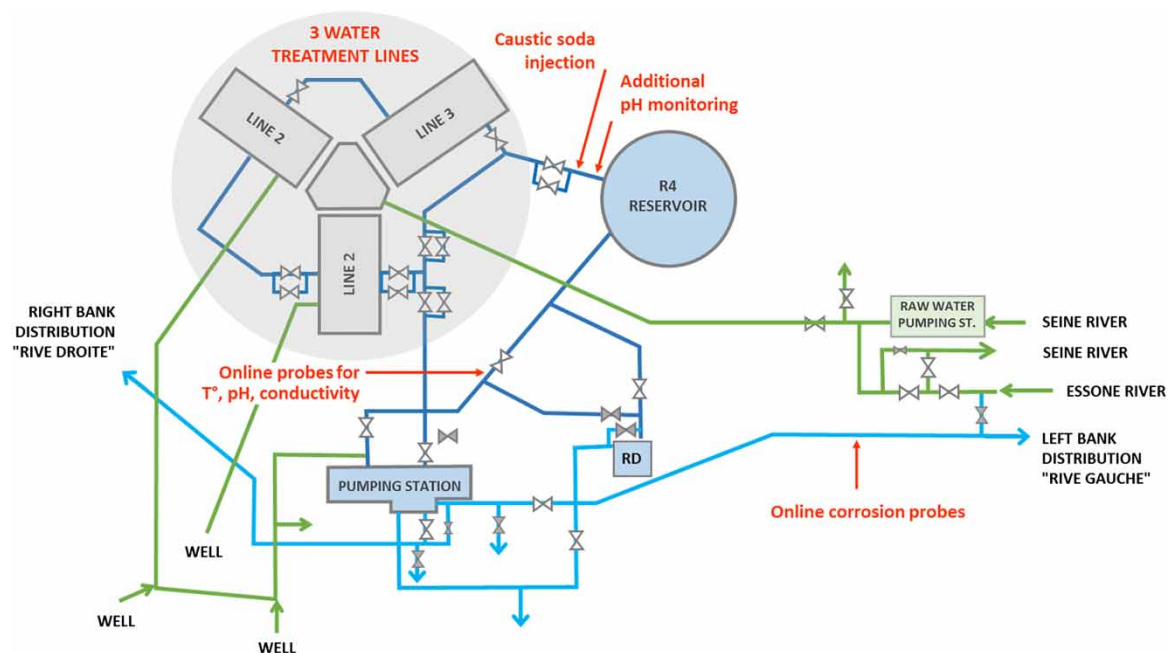

Figure 2 | Plant schematic with corrosion control system.

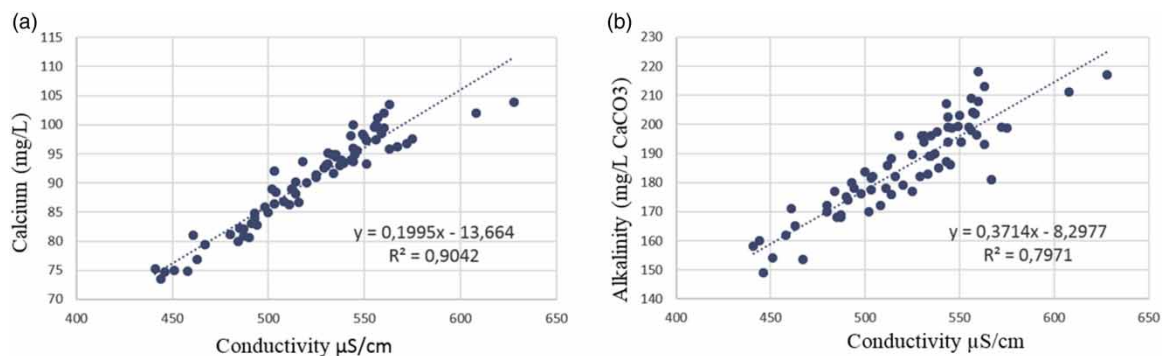

Figure 3 | Correlation between conductivity as online surrogate and (a) calcium and (b) alkalinity (2011–2016 data).

Satisfactory correlations were obtained for calcium and alkalinity as a function of conductivity from historic data (Figure 3). Online data was produced every 15 minutes by inline probes for temperature, conductivity and pH positioned at the outlet of the R4 treated water reservoir. Laboratory measurements for pH, calcium and alkalinity were run in parallel on a weekly basis.

To complete the system, instantaneous corrosion rates were measured via 2 linear polarization rate probes (Corrater, Rohrback Cosasco, USA); one equipped with cast iron electrodes, the other with lead electrodes. Probes were installed on a DN80 mm diameter pipe (pressure of 6 bar) downstream of the 'R4' treated water reservoir and upstream of a secondary 'Rive Gauche' finished water clearwell. Installed probes are shown in Figure 4.



Figure 4 | Online lead and cast iron corrosion probes at plant outlet.

RESULTS AND DISCUSSION

The system was implemented as a decision aid tool providing pH set points displayed on the SCADA. Actual adjustments required the intervention of plant operators who played a role in the effectiveness of the solution.

The system was run over 7 months with 2 interruptions in the caustic soda injection system: the first on March 22nd over 2 hours, the second on July 10th over 24 hours. A hydraulic incident that reduced the water flowrate to the corrosion probes and affected corrosion rate readings was also observed over April 21st to 27th.

Finished water quality data over the 7-month study period are summarized in Table 3.

Table 3 | Finished water quality data for Morsang WTP over study period (January – August 2017)

	Unit	Online measures				Laboratory control			
		Num. values	Ave	Min	Max	Num. values	Ave	Min	Max
Temperature	°C		14.8	2.3	26.3	228	15.5	2.7	26.3
Conductivity	µS/cm		512	458	580	35	519	428	600
pH	–	19.957	7.6	7.3	7.8	28	7.7	7.5	8.0
Alkalinity ^a	mg/L CaCO ₃		188	158	216	70	183	149	232
Calcium ^a	mg/L		93	77	107	46	90	73	102
Magnesium	mg/L	–	–	–	–	46	3.6	1.3	5.5
Sodium	mg/L	–	–	–	–	3	14.0	9.9	16.7
Chlorides ^b	mg/L	–	19	–	–	35	18.3	11.9	29.4
Sulphates ^a	mg/L	–	47	–	–	35	46.8	37.8	56.0

^aonline values determined by conductivity correlation.

^bonline values fixed based on recent average levels.

Cement corrosion control

The proposed solution uses only 3 parameters (temperature, conductivity and pH) to determine the target pH which offers the advantage of using online probes considered as simple, reliable and inexpensive. During the first weeks however, deviations were observed between online and laboratory values of conductivity affecting the accuracy of estimated calcium and alkalinity used to determine the saturation pH. This issue was linked to maintenance problems on the conductivity probe. After calibration, calculated calcium and alkalinity values were re-aligned with those obtained by laboratory analyses.

Figure 5 shows results for finished water LSI. Aside from the 2 voluntary interruptions in the system, divergences from the target pH range result mainly from the fact that operators were not always reactive in making the necessary adjustments to treatment, particularly in the early stages of the test.

Lead corrosion control

Corrosion rates were maintained at stable levels of approximately $20 \mu\text{m}/\text{year}$ when pH was kept above 7.5 (Figure 6). Lead corrosion rates increased from the baseline level of $20 \mu\text{m}/\text{year}$ to about $40 \mu\text{m}/\text{year}$ when the pH decreased below the 7.5 threshold. Direct measurements of the instantaneous corrosion rates provided by the LPR probes react rapidly to deviations in the treatment target.

Iron corrosion control

Corrosion rates were maintained below the maximum threshold established at $50 \mu\text{m}/\text{year}$ after a stabilization period of approximately 3 weeks (Figure 7). Short-spanded deviations in the CI did not impact the measured corrosion rate. This is likely due to the accumulation of a stable corrosion deposit that protects the surface of the probe plate that is therefore not destabilized over short time

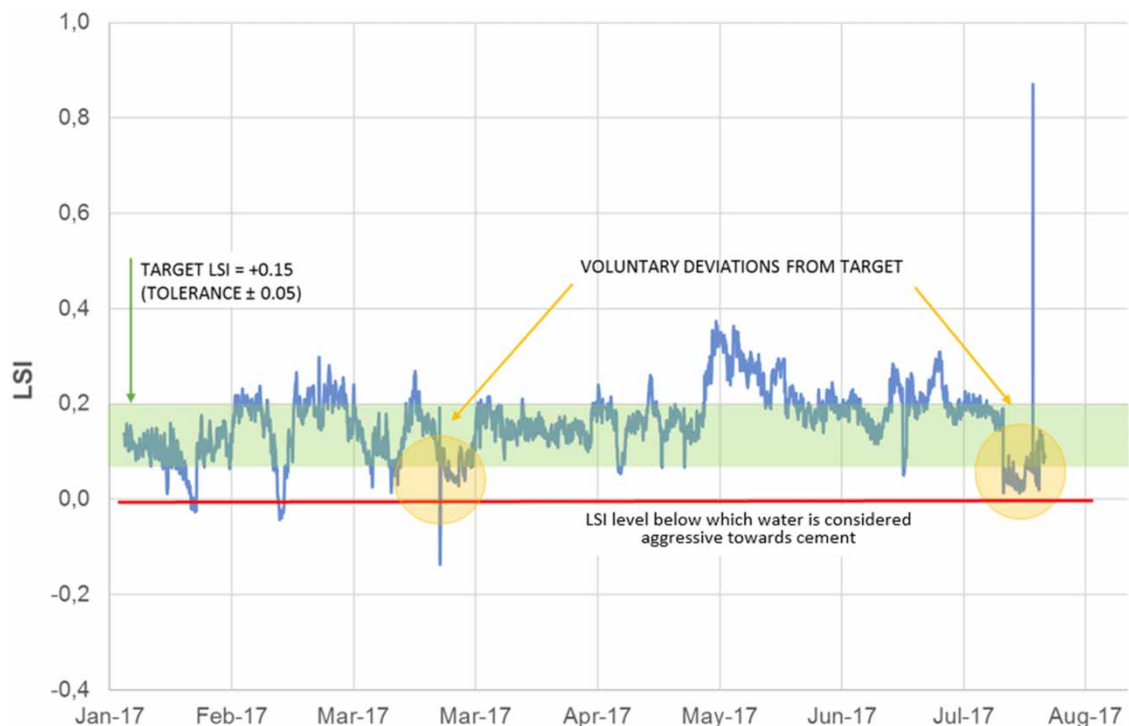

Figure 5 | Plant performance for monitoring and control of cement corrosion potential (via target LSI of 0.15 ± 0.05).

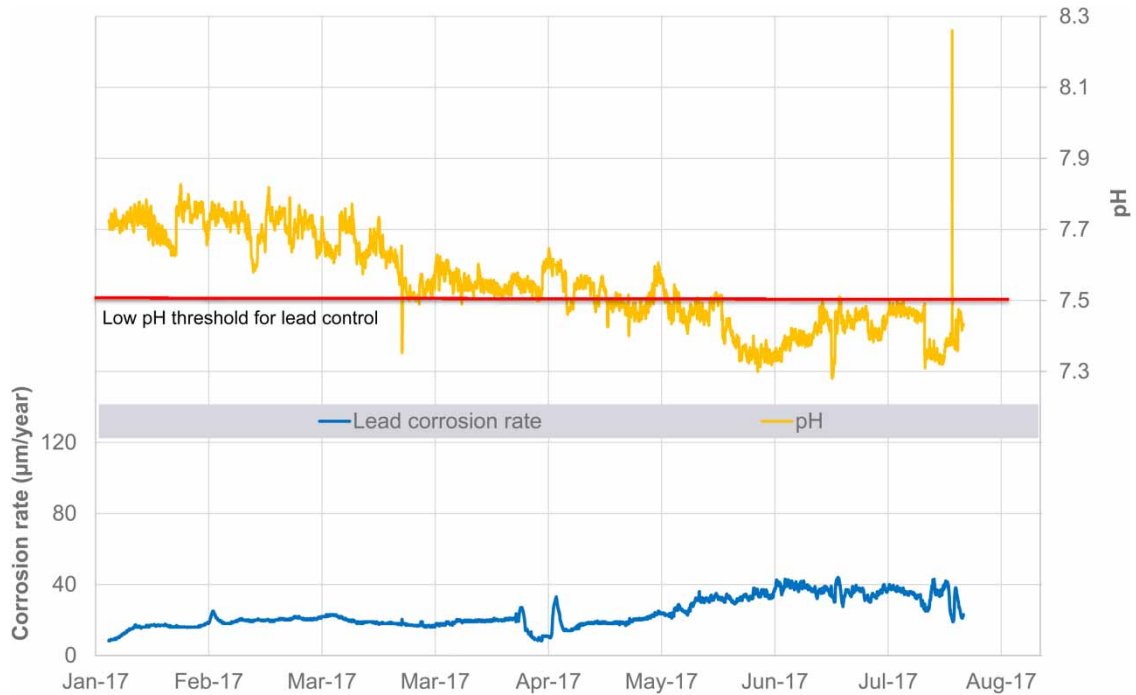

Figure 6 | Plant performance for monitoring and control of lead corrosion risk (via target pH set at >7.5).

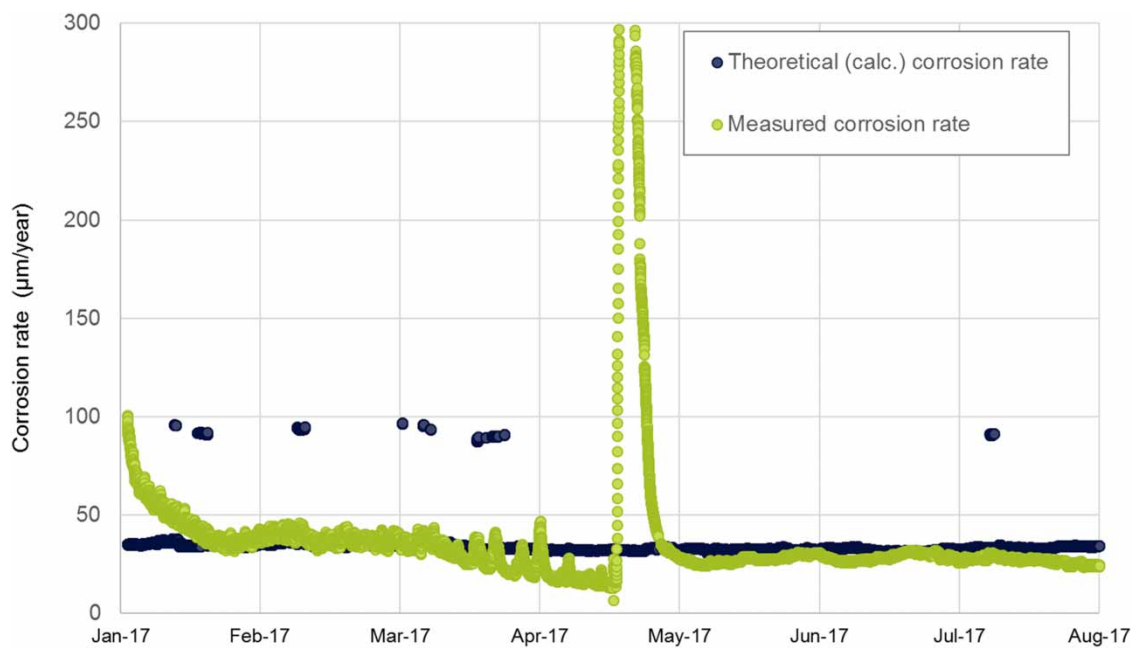

Figure 7 | Plant performance for monitoring and control of iron corrosion potential (via target corrosion rate set at <50 µm/year).

spans (Lahav & Birnhack 2007). This is likely the case for the inner wall of distribution pipes as well. Theoretical corrosion rates determined with the correlation proposed by Philibert (Equation (1)) conform quite well to actual corrosion rates measured by the LPR probe.

$$\text{Corrosion rate(CR)} = 25,592 \cdot \text{CI} + 23,936 \quad (1)$$

Finally, periods of flow disruption and stagnation in the pipeline where LPR probes are installed generate high measured corrosion rates.

Table 4 | Performance of system in terms of established treatment targets

Material of concern	Treatment target	Performance over 2009–2016	Performance over study period ^a (Jan – Aug 2017)
Cement	LSI in range 0.1–0.2 (slightly scale forming) 80% of the time	LSI in range 0.1–0.2: 16% of the time	LSI in range 0.1–0.2: 53% of the time
	LSI in the range 0.2–0.3 (scale forming) the remaining 20% of the time	LSI in range 0.2–0.3: 24% of the time	LSI in range 0.2–0.3: 6% of the time
	No LSI values < 0 (aggressive water)	LSI < 0: 7% of the time	LSI < 0: 1% of the time
Lead	pH > 7.5 during 95% of the time (moderate to low risk)	pH > 7.5: 93% of time	pH > 7.5: 64% of time
	7.3 < pH ≤ 7.5 during the remaining 5% of the time	7.3 < pH ≤ 7.5: 7% of time	7.3 < pH ≤ 7.5: remaining 36% of time
Iron	CI levels < 2 all the time with associated measured corrosion rates below 50 µm/year	CI < 2: 95% of time No direct measure of corrosion rate	CI < 2: 98% of time Direct corrosion rate < 50 µm/year: 100%

^aExcluding data during 12 hours of voluntary interruption of system and initial probe stabilization over first 3 weeks.

Results on the achievement of treatment targets are provided in [Table 4](#).

In summary, the study produced the following key results:

Cement control: Compliance with target pH increased by 30% compared to historic levels. The occurrence of aggressive water (LSI < 0) decreased from 7% to 1% of the time. The target range of LSI corresponding to slightly scale-forming water however was only achieved 53% of the time instead of the intended 80%. This is mainly due to the absence of direct control over the plant regulation set points. Plant operators were not always responsive to the recommended adjustments, particularly over the weekends.

Lead control: Finished water pH was maintained above the 7.5 threshold 64% of the time and above the 7.3 threshold 99.7% of the time. When pH remains above the 7.5 level, measured levels of lead corrosion rates are maintained below 20 µm/year.

For iron: Low levels below 50 µm/year were maintained 100% of the time even during short-term deviations from treatment targets. This objective was achieved excluding the initial probe stabilization period of approximately 3 weeks and the periods of no flow velocity when probe readings are not valid.

CONCLUSION

This experience demonstrated the feasibility of implementing online and continuous monitoring of drinking water corrosion potential towards cement, lead and iron on a full-scale plant. LPR probes for lead and iron effectively produced direct measurements of corrosion rates that are consistent with anticipated levels determined from water quality indicators. These measurements confirmed the interest of a minimum pH level of 7.5 for lead corrosion control and the relevance of the selected Corrosion Indicator to anticipate iron corrosion. Contrary to the lead probe, the iron probe exposed to slightly scale-forming water over several weeks was not sensitive to short-term water quality changes. The use of correlations translating online conductivity into values for alkalinity and calcium was effective as long as the plant instrumentation was properly calibrated. For the Morsang WTP, it was possible to reduce the corrosion potential of the produced water for cement and iron by adjusting the doses of caustic soda at the end of the treatment to achieve a target LSI within the range of 0.1–0.2. Lead corrosion control objectives conflicted with requirements to limit calcium precipitation but performance was maintained at low to moderate risk.

The system's effectiveness can be improved by enhancing its integration into plant operations with a direct control of the finished water pH set-point or the implementation of SCADA alerts if deviations from recommended targets occur. Finally, the solution allows operators to register and report on produced water corrosion control to demonstrate accountability with respect to the full water supply system: from plant to tap.

REFERENCES

- AGHTM 2000 Contrôle de la concentration en plomb dans l'eau : Echantillonnage, prélèvement, analyse et interprétation. American Water Works Association Research Foundation, DVGW-Technologiezentrum Wasser 1996 *Internal Corrosion of Water Distribution System*, 2nd edn. AWWARF and DVGW, Denver.
- Brossia, S., Det Norske Veritas Inc. 2014 The use of probes for detecting corrosion in underground pipelines. In: *Underground Pipeline Corrosion*. Woodhead Publishing, Cambridge, UK.
- Cuppett, J. 2016 *Lead and Copper Corrosion: An Overview of WRF Research*. Water Research Foundation.
- DeBerry, D. W., Kidwell, J. R. & Malish, D. A. 1982 *Corrosion in Potable Water Systems – Final Report*. USEPA, Washington, DC.
- Duranceau, S. J., Pfeiffer-Wilder, R. J., Douglas, S. A., Peña-Holt, N. & Watson, I. C. 2011 *Post-treatment Stabilization of Desalinated Water*. Water Research Foundation, Denver, CO.
- Hu, J., Dong, H., Xu, Q., Ling, W., Qu, J. & Qiang, Z. 2018 [Impacts of water quality on the corrosion of cast iron pipes for water distribution and proposed source water switch strategy](#). *Water Research* **129**, 428–435.
- Kinet, N., Rabaud, B. & Zraick, F. 2018 Insights gathered from 138 drinking water distribution pipe autopsies. In *Proceedings of the AWWA Water Infrastructure Conference & Exposition*, Atlanta, USA.
- Lahav, O. & Birnhack, L. 2007 [Quality criteria for desalinated water following post-treatment](#). *Desalination* **207**, 286–303.
- Langelier, W. F. 1936 [The analytical control of anti-Corrosion water treatment](#). *Journal of AWWA* **28**, 1500.
- Lassovsky, P., Singley, J. E., Beaudet, B. A. & Markey, P. H. 1984 *Corrosion Manual for Internal Corrosion of Water Distribution Systems*. US Environmental Protection Agency, Washington, DC, USA.
- Melidis, P., Sanzidou, M., Mandusa, A. & Ouzounis, K. 2017 [Corrosion control by using indirect methods](#). *Desalination* **213**, 152–158.
- Mirzabeygi, M., Naji, M., Yousefi, N., Shams, M., Biglari, H. & Hossein Mahvi, A. 2016 [Evaluation of corrosion and scaling tendency indices in water distribution system: a case study of Torbat Heydariye, Iran](#). *Desalination and Water Treatment* **57**, 25918–25926.
- Philibert, M., Rabaud, B., Zraick, F. & Mendaza, S. 2017 [Predicting the effect of water quality on water distribution cast iron and steel pipes using two novel indices](#). *Water Science & Technology: Water Supply* **18**, 524–538.
- Piriou, P. 2011 Centralised Water Softening in France. *Gas Wasser Abwasser* 8/2011.
- Plottu-Pecheux, A., Democrate, C., Houssais, B., Gatel, D. & Cavard, J. 2001 [Controlling the corrosiveness of blended waters](#). *Desalination* **138**, 237–249.
- Rajani, B. & Kleiner, Y. 2013 [External and internal corrosion of large diameter cast iron mains journal of infrastructure systems](#). *Journal of Infrastructure Systems* **19**, 486–495.
- Sander, A., Berghult, B., Ahlberh, E., Elfstrom Broo, A., Lind Johansson, E. & Hedberg, T. 1997 [Iron corrosion in drinking water distribution systems – surface complexation aspects](#). *Corrosion Science* **39**, 77–93.
- Shi, B. & Taylor, J. S. 2007 [Potential impact of enhanced coagulation on corrosion by-product release in a distribution system](#). *Desalination* **208**, 260–268.
- Soukatchoff, P., Baron, J. & Lessirard, L. 2001 [Cement-based materials used in drinking water pipe systems](#). *Water Science and Technology: Water Supply* **1**, 227–236.
- Spencer, C. 2003 *Revised Guidance Manual for Selecting Lead and Copper Control Strategies*. US Environmental Protection Agency, Washington, DC, USA.
- World Health Organization 2017 *Guidelines for Drinking-Water Quality*. World Health Organization, Geneva.
- Yang, F., Shi, B., Gu, J., Wang, D. & Yang, M. 2012 [Morphological and physicochemical characteristics of iron corrosion scales formed under different water source histories in a drinking water distribution system](#). *Water Research* **46**, 5423–5433.